

Canadian Price List Index



Schulte Industries Ltd.

100 John Schulte Dr., Englefeld, SK. Canada, S0K 1N0
Tel: 306-287-3715 Fax: 306-287-3355 Toll Free: 1-800-404-6044

Web: www.Schulte.ca

Sourcewell - Road Right Of Way Maintenance Equipment



Click on this symbol to
return to this index page



Snow Blowers

SDX-144 Snow Blower

RDX-117 Snow Blower

SDX-117 Snow Blower

SDX-102 Snow Blower

FM-350 Front Mount 3pt Hitch Frame

FM-115 Front Mount 3pt Hitch Frame

SBX-87 Skid Steer Snow Blower

SBX-87 3pt Snow Blower

Ground Maintenance

SRW-1400/H - 14 ft Rock Windrower

SRW-1000 - 10 ft Rock Windrower

SRW-800 - 8 ft Rock Windrower

SMR-800 - Skid-Steer 8 ft Landscape Rake

SMR-600 - Skid-Steer 6 ft Landscape Rake

RS320 Jumbo - RS320 Jumbo Rock Picker

2500 Giant - 2500 Giant Rock Picker

3500 Giant - 3500 Giant Rock Picker

5000 Titan II - 5000 Titan II Rock Picker

SPARTAN RWP-1935 - Rock Picker / Windrower Combo

MASTER PRICE SHEET



Schulte Industries Ltd.

100 John Schulte Dr., Englefeld, SK. Canada, S0K 1N0

Tel: 306-287-3715 Fax: 306-287-3355 Toll Free: 1-800-404-6044

Web: www.Schulte.ca

Sourcewell - Road Right Of Way Maintenance Equipment

MACHINE PRICES AND SPECIFICATIONS

SDX-144 SNOW BLOWER



SDX-144 Snow Blower Specs:

| | |
|---------------------------|---|
| Cutting Width: 144" | Adjustable, replaceable skid shoes |
| Tractor HP: 180 - 350 HP | Replaceable & reversible Cutting Blade |
| Cutting Height: 45.5" | Gear Driven Rotator |
| Lower Auger Diameter: 23" | High molecular plastic chute rotating surface |
| Upper Auger Diameter: 14" | Double chute deflector on HD and Truck loading chutes |
| Fan Diameter: 38" | Serrated Tooth Top & Bottom Augers |
| Fan Type: 5 Paddle | Capacity - Dry Snow / Wet Snow |
| Drive: 1000 RPM | 762 tons per hr / 2394 per hr |

~ ~ Selection 1 ~ Choose a Basic Unit ~ ~

| | | <i>Retail Price</i> | <i>Contract Price</i> |
|----------|----------------------------|---------------------|-----------------------|
| B144-100 | SDX-144 (144" Snow Blower) | 31,150.00 | 21,182.00 |

~ ~ Selection 2 ~ Choose a Gear Box ~ ~

| | | | |
|-----------|--|----------|----------|
| 330-655WG | Standard Gearbox (<i>tractors with cw pto rotation</i>) | 6,268.00 | 4,262.24 |
| 330-655R | Non-standard Gearbox (<i>tractors with ccw pto rotation</i>) | 6,530.00 | 4,440.40 |

~ ~ Selection 3 ~ Choose a Power Shaft ~ ~

| | | | |
|-----------|--------------------------------|----------|----------|
| 340-946WG | 1-3/8 Z21 (size 9) for SDX-144 | 1,699.00 | 1,155.32 |
| 340-947WG | 1-3/4 Z20 (size 9) for SDX-144 | 1,699.00 | 1,155.32 |

~ ~ Selection 4 ~ Category 4 Hitch ~ ~

| | | | |
|----------|--------------------------------------|--------|--------|
| B144-440 | Category 4 Hitch (<i>Optional</i>) | 335.00 | 227.80 |
|----------|--------------------------------------|--------|--------|

MASTER PRICE SHEET



Schulte Industries Ltd.

100 John Schulte Dr., Englefeld, SK. Canada, S0K 1N0

Tel: 306-287-3715 Fax: 306-287-3355 Toll Free: 1-800-404-6044

Web: www.Schulte.ca

Sourcewell - Road Right Of Way Maintenance Equipment

MACHINE PRICES AND SPECIFICATIONS

SDX-144 SNOW BLOWER



~ ~ **Selection 5 ~ Choose a Chute kit ~ ~**

| | | | |
|--|--|----------|-----------------|
| B110-270 | Heavy Duty Chute Kit with Dbl Chute Deflector | 2,328.00 | 1,583.04 |
| B840-250 | Cylinder Kit for B110-270 (Required) | 628.00 | 427.04 |
| B110-280 | Truck Loading Chute Kit with Dbl Chute Deflector | 3,219.00 | 2,188.92 |
| B110-260 | Cylinder Kit for B110-280 (Required) | 660.00 | 448.80 |
| <u>NOTE:</u> Cylinder kits are complete with 2" x 6" cylinder & hoses | | | |
| B117-220 | Folding Truck Loading Chute | 5,422.00 | 3,686.96 |
| <u>NOTE:</u> Hoses & Two Cylinders Included in B117-220 | | | |

| | | | |
|--|----------|-----|---------------|
| | Assembly | Net | 275.00 |
|--|----------|-----|---------------|



MASTER PRICE SHEET



Schulte Industries Ltd.

100 John Schulte Dr., Englefeld, SK. Canada, S0K 1N0
 Tel: 306-287-3715 Fax: 306-287-3355 Toll Free: 1-800-404-6044
 Web: www.Schulte.ca

Sourcewell - Road Right Of Way Maintenance Equipment

MACHINE PRICES AND SPECIFICATIONS

RDX-117 SNOW BLOWER



RDX-117 Snow Blower Specs:

| | |
|---------------------------|---|
| Cutting Width: 117" | Adjustable, replaceable skid shoes |
| Tractor HP: 140 - 220 HP | Replaceable & reversible Cutting Blade |
| Cutting Height: 45.5" | Gear Driven Rotator |
| Lower Auger Diameter: 23" | High molecular plastic chute rotating surface |
| Upper Auger Diameter: 14" | Double chute deflector on HD and Truck loading chutes |
| Fan Diameter: 38" | Capacity - Dry Snow / Wet Snow |
| Fan Type: 5 Paddle | 762 tons per hr / 2394 per hr |
| Drive: 1000 RPM | |

~ ~ Selection 1 ~ Choose a Basic Unit ~ ~

| | | <i>Retail Price</i> | <i>Contract Price</i> |
|----------|----------------------------|---------------------|-----------------------|
| B118-000 | RDX-117 (117" Snow Blower) | 31,689.00 | 21,548.52 |

~ ~ Selection 2 ~ Choose a Gear Box ~ ~

| | | | |
|-----------|--|----------|----------|
| 330-655WG | Standard Gearbox (<i>tractors with cw pto rotation</i>) | 6,268.00 | 4,262.24 |
| 330-655R | Non-standard Gearbox (<i>tractors with ccw pto rotation</i>) | 6,530.00 | 4,440.40 |

~ ~ Selection 3 ~ Choose a Power Shaft ~ ~

| | | | |
|-----------|--|----------|--------|
| 340-926WG | 1-3/4 Z20 (size 9) for SDX-117 / RDX-117 | 1,450.00 | 986.00 |
| 340-925WG | 1-3/8 Z21 (size 9) for SDX-117 / RDX-117 | 1,450.00 | 986.00 |

NOTE: Do not order above shaft if going on a FM350

MASTER PRICE SHEET



Schulte Industries Ltd.

100 John Schulte Dr., Englefeld, SK. Canada, S0K 1N0

Tel: 306-287-3715 Fax: 306-287-3355 Toll Free: 1-800-404-6044

Web: www.Schulte.ca

Sourcewell - Road Right Of Way Maintenance Equipment

MACHINE PRICES AND SPECIFICATIONS

RDX-117 SNOW BLOWER



~ ~ Selection 4 ~ Choose a Chute kit ~ ~

| | | | |
|--|--|----------|----------|
| B110-270 | Heavy Duty Chute Kit with Dbl Chute Deflector | 2,328.00 | 1,583.04 |
| B840-250 | Cylinder Kit for B110-270 (Required) | 628.00 | 427.04 |
| B110-280 | Truck Loading Chute Kit with Dbl Chute Deflector | 3,219.00 | 2,188.92 |
| B110-260 | Cylinder Kit for B110-280 (Required) | 660.00 | 448.80 |
| <u>NOTE:</u> Cylinder kits are complete with 2" x 6" cylinder & hoses | | | |
| B117-220 | Folding Truck Loading Chute | 5,422.00 | 3,686.96 |
| <u>NOTE:</u> Hoses & Two Cylinders Included in B117-220 | | | |
| B890-300WG | Gauge Wheels with Tapered Roller Bearings | 2,603.00 | 1,770.04 |
| | Assembly | Net | 225.00 |



MASTER PRICE SHEET



Schulte Industries Ltd.

100 John Schulte Dr., Englefeld, SK. Canada, S0K 1N0

Tel: 306-287-3715 Fax: 306-287-3355 Toll Free: 1-800-404-6044

Web: www.Schulte.ca

Sourcewell - Road Right Of Way Maintenance Equipment

MACHINE PRICES AND SPECIFICATIONS

SDX-117 SNOW BLOWER



SDX-117 Snow Blower Specs:

| | |
|---------------------------|---|
| Cutting Width: 117" | Adjustable, replaceable skid shoes |
| Tractor HP: 140 - 220 HP | Replaceable & reversible Cutting Blade |
| Cutting Height: 45.5" | Gear Driven Rotator |
| Lower Auger Diameter: 23" | High molecular plastic chute rotating surface |
| Upper Auger Diameter: 14" | Double chute deflector on HD and Truck loading chutes |
| Fan Diameter: 38" | Capacity - Dry Snow / Wet Snow |
| Fan Type: 5 Paddle | 762 tons per hr / 2394 per hr |
| Drive: 1000 RPM | |

~ ~ Selection 1 ~ Choose a Basic Unit ~ ~

| | | <i>Retail Price</i> | <i>Contract Price</i> |
|----------|----------------------------|---------------------|-----------------------|
| B117-000 | SDX-117 (117" Snow Blower) | 25,561.00 | 17,381.48 |

~ ~ Selection 2 ~ Choose a Gear Box ~ ~

| | | | |
|-----------|--|----------|-----------------|
| 330-655WG | Standard Gearbox (<i>tractors with cw pto rotation</i>) | 6,268.00 | 4,262.24 |
| 330-655R | Non-standard Gearbox (<i>tractors with ccw pto rotation</i>) | 6,530.00 | 4,440.40 |

~ ~ Selection 3 ~ Choose a Power Shaft ~ ~

| | | | |
|-----------|--|----------|---------------|
| 340-926WG | 1-3/4 Z20 (size 9) for SDX-117 / RDX-117 | 1,450.00 | 986.00 |
| 340-925WG | 1-3/8 Z21 (size 9) for SDX-117 / RDX-117 | 1,450.00 | 986.00 |

NOTE: Do not order above shaft if going on a FM350

Instead, order from FM350 price sheet

MASTER PRICE SHEET



Schulte Industries Ltd.

100 John Schulte Dr., Englefeld, SK. Canada, S0K 1N0

Tel: 306-287-3715 Fax: 306-287-3355 Toll Free: 1-800-404-6044

Web: www.Schulte.ca

Sourcewell - Road Right Of Way Maintenance Equipment

MACHINE PRICES AND SPECIFICATIONS

SDX-117 SNOW BLOWER



~ ~ Selection 4 ~ Choose a Chute kit ~ ~

| | | | |
|--|--|----------|-----------------|
| B110-270 | Heavy Duty Chute Kit with Dbl Chute Deflector | 2,328.00 | 1,583.04 |
| B840-250 | Cylinder Kit for B110-270 <i>(Required)</i> | 628.00 | 427.04 |
| B110-280 | Truck Loading Chute Kit with Dbl Chute Deflector | 3,219.00 | 2,188.92 |
| B110-260 | Cylinder Kit for B110-280 <i>(Required)</i> | 660.00 | 448.80 |
| <u>NOTE:</u> Cylinder kits are complete with 2" x 6" cylinder & hoses | | | |
| B117-220 | Folding Truck Loading Chute | 5,422.00 | 3,686.96 |
| <u>NOTE:</u> Hoses & Two Cylinders Included in B117-220 | | | |
| B890-300WG | Gauge Wheels with Tapered Roller Bearings | 2,603.00 | 1,770.04 |
| | Assembly | Net | 225.00 |



MASTER PRICE SHEET



Schulte Industries Ltd.

100 John Schulte Dr., Englefeld, SK. Canada, S0K 1N0
 Tel: 306-287-3715 Fax: 306-287-3355 Toll Free: 1-800-404-6044
 Web: www.Schulte.ca

Sourcewell - Road Right Of Way Maintenance Equipment

MACHINE PRICES AND SPECIFICATIONS

SDX-102 SNOW BLOWER



SDX-102 Snow Blower Specs:

| | |
|------------------------|---------------------------------------|
| Cutting Width: 102" | Adjustable, replaceable skid shoes |
| Drive: 540 or 1000 RPM | Replaceable Cutting Blade |
| Cutting Height: 35" | Gear Driven Rotator |
| Overall Height: 96" | Hydraulic Chute Rotation |
| Auger Diameter: 23" | Capacity Dry Snow/Wet Snow |
| Fan Diameter: 30" | 388 Tons per hr / 1222 tons per hr |
| Fan Type: 4 Paddle | Tractor HP: 85 - 140 HP (63 - 104 kw) |

~ ~ Selection 1 ~ Choose a Basic Unit ~ ~

| | | <i>Retail Price</i> | <i>Contract Price</i> |
|----------|----------------------------------|---------------------|-----------------------|
| B102-000 | SDX102 Standard Drum Snow Blower | 17,986.00 | 12,230.48 |

~ ~ Selection 2 ~ Choose a Power Shaft ~ ~

| | | | |
|-----------|--|----------|----------|
| 340-924WG | Size 9 Heavy Duty PTO Shaft <i>540 RPM</i> | 1,450.00 | 986.00 |
| 340-927WG | Size 9 Heavy Duty PTO Shaft (for TV-145 Engine End) <i>540 RPM</i> | 1,300.00 | 884.00 |
| | <i>Optional Gear Gbox</i> | | |
| B102-175 | 1000 RPM Gear Box STANDARD CW Rotation | 2,297.00 | 1,561.96 |
| B102-175R | 1000 RPM Gear Box CCW Rotation | 2,643.00 | 1,797.24 |
| | <i>Power Shaft for 1000 RPM Gear Box</i> | | |
| 340-928WG | 1-3/8 21 Spline shaft 1000 RPM | 1,585.00 | 1,077.80 |

NOTE: Do not order above shaft if going on a FM350 or FM115

Instead, order from FM350 price sheet

~ ~ Selection 3 ~ Choose a Chute Kit ~ ~

| | | | |
|----------|---|----------|----------|
| B110-270 | Heavy Duty Chute Kit with Dbl Chute Deflector | 2,328.00 | 1,583.04 |
| B840-250 | Cylinder Kit for B110-270 (Required) | 628.00 | 427.04 |
| B110-280 | Truck Loading Chute Kit with Dbl Chute Deflector | 3,219.00 | 2,188.92 |
| B110-260 | Cylinder Kit for B110-280 (Required) | 660.00 | 448.80 |
| | <i>NOTE: Cylinder kits are complete with 2" x 6" cylinder & hoses</i> | | |
| B102-250 | Folding Truck Loading Chute | 5,414.00 | 3,681.52 |

NOTE: Hoses & Two Cylinders Included in B102-250

MASTER PRICE SHEET



Schulte Industries Ltd.

100 John Schulte Dr., Englefeld, SK. Canada, S0K 1N0

Tel: 306-287-3715 Fax: 306-287-3355 Toll Free: 1-800-404-6044

Web: www.Schulte.ca

Sourcewell - Road Right Of Way Maintenance Equipment

MACHINE PRICES AND SPECIFICATIONS

SDX-102 SNOW BLOWER



~ ~ Selection 4 ~ Choose a Extra Options ~ ~

| | | |
|--|----------|-----------------|
| B890-300WG Gauge Wheels with Tapered Roller Bearings | 2,603.00 | 1,770.04 |
| Assembly | Net | 150.00 |



MASTER PRICE SHEET

Schulte Industries Ltd.

100 John Schulte Dr., Englefeld, SK. Canada, S0K 1N0

Tel: 306-287-3715 Fax: 306-287-3355 Toll Free: 1-800-404-6044

Web: www.Schulte.ca



Sourcewell - Road Right Of Way Maintenance Equipment

MACHINE PRICES AND SPECIFICATIONS

FM-350 Front Mount 3pt Hitch Frame



FM-350 Specs:

Tractor HP: 85 HP - 250 HP

Tractor PTO - 1000 rpm for SDX-117 and SDX-102

Adjustment: Accommodates tractors between 151" and 211" measured from mount plate to drawbar pin

540 rpm for SDX-102 only

Lift Capacity : 5000 lbs

Nominal Ground Clearance - 13" depending on tractor installation

Nominal Lift Range - 18"

Weight - 1650 lbs

~ ~ Selection 1 ~ Choose a Basic Unit ~ ~

| | | Retail Price | Contract Price |
|----------|---|--------------|----------------|
| F350-100 | FM-350 Front Mount Frame (NO Driveline Package) <i>Used for SV 3pt V-BLADE (must choose for all attachments)</i> <i>Includes 2 hydraulic banks for operation</i> | 11,657.00 | 7,926.76 |
| F350-200 | Driveline package (Used for Snow Blowers) | 7,465.00 | 5,076.20 |

~ ~ Selection 2 ~ Choose Gear Box ~ ~

| | | | |
|----------|--|----------|----------|
| F250-310 | 1:1 Rear Gear Box <i>Select when connecting a 1000 RPM PTO tractor to a SDX-117 or RDX-117 or when connecting a 540 RPM PTO tractor to a SDX-102 or RDX-102 snow blower</i> | 3,895.00 | 2,648.60 |
| F250-300 | 1000 to 540 RPM Rear Reduction Gearbox <i>Select when connecting a 1000 RPM PTO tractor to a SDX-102 or RDX-102</i> | 3,895.00 | 2,648.60 |

~ ~ Selection 3 ~ Choose REAR TRACTOR SHAFT ~ ~

NOTE: Power delivered from a 1,000 RPM tractor only

| | | | |
|-----------|--|----------|--------|
| 340-662WG | 1-3/8 Z21 for SDX-102 / RDX-102 | 1,015.00 | 690.20 |
| 340-663WG | 1-3/4 Z20 for SDX-102 / RDX-102 | 1,015.00 | 690.20 |
| 340-925WG | 1-3/8 Z21 (Size 9) for SDX-117 / RDX-117 | 1,450.00 | 986.00 |
| 340-926WG | 1-3/4 Z20 (size 9) for SDX-117 / RDX-117 | 1,450.00 | 986.00 |

NOTE: Power delivered from a 540 RPM tractor only

| | | | |
|-----------|--------------------------------|----------|--------|
| 340-924WG | 1-3/8 Z6 for SDX-102 / RDX-102 | 1,450.00 | 986.00 |
|-----------|--------------------------------|----------|--------|

MASTER PRICE SHEET



Schulte Industries Ltd.

100 John Schulte Dr., Englefeld, SK. Canada, S0K 1N0

Tel: 306-287-3715 Fax: 306-287-3355 Toll Free: 1-800-404-6044

Web: www.Schulte.ca

Sourcewell - Road Right Of Way Maintenance Equipment

MACHINE PRICES AND SPECIFICATIONS

FM-350 Front Mount 3pt Hitch Frame



~ ~ Selection 4 ~ Choose Hydraulic Bank ~ ~

| | | | |
|-----------------|--|--------|---------------|
| F300-410 | Hydraulic Bank and Mount, Single <i>Required for drum rotation on RDX-102 / RDX-117</i> | 587.00 | 399.16 |
|-----------------|--|--------|---------------|

~ ~ Selection 5 ~ Choose Options ~ ~

Tractor Mount

| | | | |
|--|--|--------|---------------|
| <i>*Please contact us for tractor mount options & availability</i> | | 750.00 | 510.00 |
|--|--|--------|---------------|

| | | |
|----------|-----|---------------|
| Assembly | Net | 100.00 |
|----------|-----|---------------|



MASTER PRICE SHEET



Schulte Industries Ltd.

100 John Schulte Dr., Englefeld, SK. Canada, S0K 1N0

Tel: 306-287-3715 Fax: 306-287-3355 Toll Free: 1-800-404-6044

Web: www.Schulte.ca

Sourcewell - Road Right Of Way Maintenance Equipment

MACHINE PRICES AND SPECIFICATIONS

FM-115 Front Mount 3pt Hitch Frame



FM-115 Specs:

Tractor HP: Max. 115 hp (86kw)

Tractor HP: Min. 55hp(41kw) for SDX-840, 85hp (63kw)for SDX-102, RDX-102

Tractor Hydraulic Requirement - 3 remote circuits with a minimum total hydraulic output of 10 GPM at 1200 PSI.rotating drum.
An additional circuit is required if the snow blower has a rotating drum (RDX-102).

Tractor PTO - 540 RPM

Lift Capacity: Maximum - 5000 lbs (1162 KG)

Adjustability - Fits tractors between 111-1/2" and 164-1/2" measured the front mount plate to the drawbar pin

Normal Lift Range - 18"

Nominal Ground Clearance - 10" depending on tractor installation

Approximate Weight - 1400 lbs (636 KG)

~ ~ Selection 1 ~ Choose a Basic Unit ~ ~

| | | Retail Price | Contract Price |
|------------------|--|---------------------|-----------------------|
| F115-100 | FM-115 Front Mount Frame (NO Driveline Package) | 9,633.00 | 6,550.44 |
| F115-200 | Driveline package (Used for Snow Blowers) | 7,453.00 | 5,068.04 |
| 340-924WG | 1-3/8 Z6 (Size 9) for RDX-102 | 1,450.00 | 986.00 |
| | Tractor Mount | 750.00 | 510.00 |
| | Assembly | Net | 100.00 |



MASTER PRICE SHEET



Schulte Industries Ltd.

100 John Schulte Dr., Englefeld, SK. Canada, S0K 1N0

Tel: 306-287-3715 Fax: 306-287-3355 Toll Free: 1-800-404-6044

Web: www.Schulte.ca

Sourcewell - Road Right Of Way Maintenance Equipment

MACHINE PRICES AND SPECIFICATIONS

SBX-87 Skid Steer SNOW BLOWERS



SBX Series Snow blower Specs:

| | |
|-------------------|-----------------------------------|
| Cutting Widths: | Replaceable Cutting Blade |
| SBX-87 87"(221cm) | Adjustable, replacable skid shoes |

Standard Skid Steer Mounting Plate and electrical harnesses available for various skid steer mode

~ ~ Selection 1 ~ Choose a Basic Unit ~ ~

| | | <i>Retail Price</i> | <i>Contract Price</i> |
|----------|---|---------------------|-----------------------|
| B870-100 | SBX-87 Base Unit <i>Includes Hydraulic Rotator and Deflection</i> | 13,307.00 | 9,048.76 |

~ ~ Selection 2 ~ Choose Motor Mount Attachment Plate & Valve Block ~ ~

| | | | |
|----------|---|----------|----------|
| B750-300 | Required Mount Kit | 1,289.00 | 876.52 |
| B750-600 | Required Skid Steer Attachment plate | 1,054.00 | 716.72 |
| B750-400 | Required Hydraulic Valve Block | 4,319.00 | 2,936.92 |

~ ~ Selection 3 ~ Choose Hydraulics and Harness Assembly ~ ~

| | | | |
|----------|---|----------|----------|
| R500-345 | Control Box Interface <i>(Choose if Brand isn't listed below)</i> | 903.00 | 614.04 |
| R500-350 | Bobcat Interface Harness | 2,796.00 | 1,901.28 |
| R500-330 | CNH/GEHL/Mustang Harness Assembly | 365.00 | 248.20 |
| R500-335 | Cat 14 Harness Assembly | 365.00 | 248.20 |
| R500-340 | John Deere Harness Assembly | 365.00 | 248.20 |
| R500-325 | Kubota Harness Assembly | 365.00 | 248.20 |
| R500-315 | JCB, Takeuchi, Volvo Harness Assembly | 365.00 | 248.20 |
| R500-355 | CAT D-Series Adapter Harness | 466.00 | 316.88 |

MASTER PRICE SHEET



Schulte Industries Ltd.

100 John Schulte Dr., Englefeld, SK. Canada, S0K 1N0

Tel: 306-287-3715 Fax: 306-287-3355 Toll Free: 1-800-404-6044

Web: www.Schulte.ca

Sourcewell - Road Right Of Way Maintenance Equipment

MACHINE PRICES AND SPECIFICATIONS

SBX-87 Skid Steer

SNOW BLOWERS



~ ~ Selection 4 ~ Choose Motor to Match Flow ~ ~

| | | | |
|-----------|--|----------|-----------------|
| 116-214WG | Hydraulic Motor, 6.2 cu. in. For 15-19 GPM Flow | 1,383.00 | 940.44 |
| 116-902WG | Hydraulic Motor, 8.0 cu. in. For 20-24 GPM Flow | 1,541.00 | 1,047.88 |
| 116-903WG | Hydraulic Motor, 9.6 cu. in. For 25-29 GPM Flow | 1,617.00 | 1,099.56 |
| 116-904WG | Hydraulic Motor, 11.9 cu. in. For 30-35 GPM Flow | 1,706.00 | 1,160.08 |

| | | |
|----------|-----|---------------|
| Assembly | Net | 350.00 |
|----------|-----|---------------|



MASTER PRICE SHEET



Schulte Industries Ltd.

100 John Schulte Dr., Englefeld, SK. Canada, S0K 1N0

Tel: 306-287-3715 Fax: 306-287-3355 Toll Free: 1-800-404-6044

Web: www.Schulte.ca

Sourcewell - Road Right Of Way Maintenance Equipment

MACHINE PRICES AND SPECIFICATIONS

SBX-87 3pt SNOW BLOWERS



SBX 3 PT Snow Blower Specs:

Cutting Widths:

SBX-87 87"(221cm)

540 RPM - cat 1 hitch

Replaceable Cutting Blade

Adjustable, replacable skid shoes

Improved larger chute design

~ ~ Selection 1 ~ Choose a Basic Unit ~ ~

| | | Retail Price | Contract Price |
|----------|---|---------------------|-----------------------|
| B870-100 | SBX-87 Base Unit <i>Includes Hydraulic Rotator and Deflection</i> | 13,307.00 | 9,048.76 |

~ ~ Selection 2 ~ Choose 3PT HITCH (important: not optional) ~ ~

| | | | |
|----------|--------------------------------|----------|-----------------|
| B750-200 | Required 3 PT Hitch Kit | 2,126.00 | 1,445.68 |
|----------|--------------------------------|----------|-----------------|

| | | |
|----------|-----|---------------|
| Assembly | Net | 100.00 |
|----------|-----|---------------|



MASTER PRICE SHEET



Schulte Industries Ltd.

100 John Schulte Dr., Englefeld, SK. Canada, S0K 1N0

Tel: 306-287-3715 Fax: 306-287-3355 Toll Free: 1-800-404-6044

Web: www.Schulte.ca



Sourcewell - Road Right Of Way Maintenance Equipment

MACHINE PRICES AND SPECIFICATIONS

- SRW-1400 - Mechanical Rock Windrower**
- SRW-1400H- Hydraulic Drive Rock Windrower**

SPECIFICATIONS

- Horsepower Required --- 40hp to 150hp, 540 rpm
- Maximum Ground Speed -- 5mph
- Recommended Ground Speed -- 2mph
- Drum Speed -- 117 rpm @ 540 input (Mechanical)
- Tires - ST205 90-15, D Load Range
- Transport Width -- 7.75'
- Transport Length -- 235"
- Hydraulic Drive Requires 15 GPM/ 57 LPM Hydraulic Flow

HOW TO ORDER: You must select from 1, 2 and 3 to receive a complete rock windrower. To receive additional options, choose from selection 4.

~ ~ Selection 1 ~ Choose a Basic Unit ~ ~

| | | | <i>Retail Price</i> | <i>Contract Price</i> |
|----|----------|------------------------------|---------------------|-----------------------|
| 1) | R210-100 | SRW1400 Base Unit (Required) | 30,151.00 | 20,502.68 |

~ ~ Selection 2 ~ Choose Drive System ~ ~

| | | | | |
|----|----------|---|----------|----------|
| 1) | R210-750 | Mechanical Drive System (540 RPM 40-150 HP) OR | 5,609.00 | 3,814.12 |
| 2) | R210-700 | Hydraulic Drive System (15 GPM Flow Minimum Needed) | 3,556.00 | 2,418.08 |

~ ~ Selection 3 ~ Choose Drum ~ ~

| | | | | |
|----|----------|--|-----------|----------|
| 1) | R210-180 | SRW1400 Drum With Bolt On Teeth (Required) | 13,688.00 | 9,307.84 |
|----|----------|--|-----------|----------|

~ ~ Selection 4 ~ Hydraulic Cylinder Kit ~ ~

| | | | | |
|----|----------|--|----------|--------|
| 1) | R210-270 | Complete Hydraulic Cylinder Kit consisting of (2) 3 x 8 hydraulic cylinders c/w depth stops, steel lines, hoses and fittings (required to operate windrower) | 1,259.00 | 856.12 |
|----|----------|--|----------|--------|

GST Exempt

PREDELIVERY SERVICE IS REQUIRED BY DEALER OR END USER

MASTER PRICE SHEET



Schulte Industries Ltd.

100 John Schulte Dr., Englefeld, SK. Canada, S0K 1N0

Tel: 306-287-3715 Fax: 306-287-3355 Toll Free: 1-800-404-6044

Web: www.Schulte.ca



Sourcewell - Road Right Of Way Maintenance Equipment

MACHINE PRICES AND SPECIFICATIONS

SRW-1400 - Mechanical Rock Windrower

SRW-1400H- Hydraulic Drive Rock Windrower

~ ~ Selection 5 ~ Extra Options ~ ~

| | | | | |
|----|----------|--|----------|----------|
| 1) | R200-220 | CE Shield Kit for SRW1400 | 4,539.00 | 3,086.52 |
| 2) | S000-065 | Safety Light Kit for SRW1400 | 929.00 | 631.72 |
| 3) | R210-200 | High Speed Sprocket (for gravel reclamation) | 598.00 | 406.64 |
| | | Assembly Charge | Net | 500.00 |

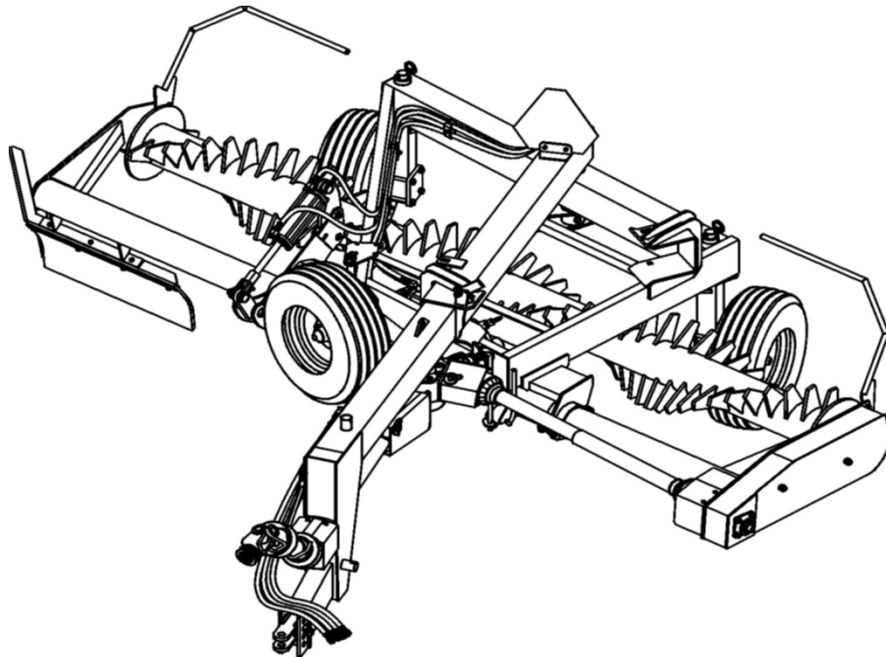

GST Exempt

PREDELIVERY SERVICE IS REQUIRED BY DEALER OR END USER



MASTER PRICE SHEET



Schulte Industries Ltd.

100 John Schulte Dr., Englefeld, SK. Canada, S0K 1N0

Tel: 306-287-3715 Fax: 306-287-3355 Toll Free: 1-800-404-6044

Web: www.Schulte.ca

Sourcewell - Road Right Of Way Maintenance Equipment

MACHINE PRICES AND SPECIFICATIONS

SRW-1000 Rock Windrower



SPECIFICATIONS

- Horsepower Required --- 40hp to 150hp (30-112KW), 540rpm
- Maximum Ground Speed -- 5mph (8kph)
- Recommended Ground Speed -- 2mph (3kph)
- Drum Speed -- 117 rpm @ 540 input
- Drum Width -- 10 ft (3.05 m)
- Tires - Forklift Tire 6.5 x 10, 10 ply
- Transport Width -- 7.75'
- Transport Length -- 235"
- Weight -- 2660 lbs (1206 kg)

~ ~ Selection 1 ~ Choose a Basic Unit ~ ~

| | | <i>Retail Price</i> | <i>Contract Price</i> |
|----------|--|---------------------|-----------------------|
| R900-100 | SWR1000 Standard 10 ft unit | 24,089.00 | 16,380.52 |
| R900-200 | Safety Light Kit (Required in North America) | 941.00 | 639.88 |

~ ~ Selection 2 ~ Choose Drive System ~ ~

| | | | |
|----------|-----------------------------------|----------|----------|
| R900-650 | Mechanical Drive System <i>OR</i> | 5,201.00 | 3,536.68 |
| R900-600 | Hydraulic Drive System | 2,919.00 | 1,984.92 |

~ ~ Selection 3 Choose Tires ~ ~

| | | | |
|-----------|--|--------|--------|
| 210-175WG | Forklift Tire 6.5 x 10, 12 ply on 2 pce 5 bolt rim | 533.00 | 362.44 |
| | <i>Must choose 2 per unit</i> | | |

~ ~ Selection 4 ~ Extra Options ~ ~

| | | | |
|----------|---------------------|--------|--------|
| R000-200 | High Speed Sprocket | 205.00 | 139.40 |
| R900-800 | Shipping Kit | Net | 289.00 |
| | Assembly | Net | 400.00 |



Assembled unit



Shipping kit installed ready for truck



MASTER PRICE SHEET



Schulte Industries Ltd.

100 John Schulte Dr., Englefeld, SK. Canada, S0K 1N0
 Tel: 306-287-3715 Fax: 306-287-3355 Toll Free: 1-800-404-6044
 Web: www.Schulte.ca

Sourcewell - Road Right Of Way Maintenance Equipment

MACHINE PRICES AND SPECIFICATIONS

SRW-800 Rock Windrower



SPECIFICATIONS

- Variable Hydraulic Drum Angle 0 degrees to 18 degrees
- Drum Speed -- 102 rpm @ 540 input
- Horsepower Required --- 35hp to 100hp
- Tires -- 16.5 x 6.5 x 8 ply
- Maximum Ground Speed -- 5mph
- Transport Width -- 8.5'
- Recommended Ground Speed -- 2mph
- Transport Length -- 67"

~ ~ **Selection 1 ~ Choose a Basic Unit** ~ ~

| | | <i>Retail Price</i> | <i>Contract Price</i> |
|----|----------------------------------|---------------------|-----------------------|
| 1) | R300-000 SRW800 Standard 8' Unit | 20,070.00 | 13,647.60 |

~ ~ **Selection 2 ~ Choose a Destination Code** ~ ~

Please select the destination of the windrower for proper Decals and Manuals.

| | | | |
|----|-------------------------------------|-------|-------|
| 1) | R300-NA North America and Australia | 51.00 | 34.68 |
|----|-------------------------------------|-------|-------|

~ ~ **Selection 3 ~ Extra Options** ~ ~

| | | | |
|----|---|--------|--------|
| 1) | R000-200 High Speed Sprocket (for gravel reclamation) | 205.00 | 139.40 |
| | Assembly Charge | Net | 200.00 |





Schulte Industries Ltd.

100 John Schulte Dr., Englefeld, SK, Canada, S0K 1N0
 Tel: 306-287-3715 Fax: 306-287-3355 Toll Free: 1-800-404-6044
 Web: www.Schulte.ca

MASTER PRICE SHEET



Sourcewell - Road Right Of Way Maintenance Equipment
 MACHINE PRICES AND SPECIFICATIONS

SMR-800 Multi Skid-steer Windrower/Landscape Rake

SPECIFICATIONS

| | | | |
|----------------------|-------------------|------------|----------------------|
| Weight (approximate) | 1900 lbs (862 kg) | Drum width | 89" (2.26 m) |
| Transport width | 102" (2.59 m) | Tires | 23" forklift (58 cm) |

~ ~ **Selection 1 ~ Choose a Basic Unit** ~ ~

| | Retail Price | Contract Price |
|---|--------------|----------------|
| R500-100 Skid-steer Windrower Base Unit | 10,589.00 | 7,200.52 |

~ ~ **Selection 2 ~ Choose One Correct Harness (With Hydraulic Rotating Opt only)** ~ ~

| | | |
|---|----------|----------|
| R500-315 Interface Harness, JCB/Takeuchi | 365.00 | 248.20 |
| R500-320 Interface Harness, Volvo | 365.00 | 248.20 |
| R500-325 Interface Harness, Kubota | 365.00 | 248.20 |
| R500-330 Interface Harness for CNH | 365.00 | 248.20 |
| R500-335 Interface Harness for Cat (14 pin) | 365.00 | 248.20 |
| R500-340 Interface Harness for JohnDeere | 365.00 | 248.20 |
| R500-345 Electric Harness With Switch Box | 903.00 | 614.04 |
| R500-350 Interface Harness for Bobcat | 2,796.00 | 1,901.28 |
| R500-355 CAT D-Series Adapter Harness | 466.00 | 316.88 |

~ ~ **Selection 3 ~ Choose Drum Configuration** ~ ~

| | | |
|---|----------|----------|
| R500-115 Standard Drum | 4,060.00 | 2,760.80 |
| <i>Choose Teeth Configuration</i> | | |
| R500-180 4 Inch Replaceable 450 BHN Steel Teeth | 1,891.00 | 1,285.88 |

~ ~ **Selection 4 ~ Choose Mount** ~ ~

| | | |
|-------------------------|----------|----------|
| R500-130 Standard Mount | 2,416.00 | 1,642.88 |
|-------------------------|----------|----------|

~ ~ **Selection 5 ~ Choose Wheel Option (must pick)** ~ ~

| | | |
|--------------------------|----------|----------|
| R500-610 Standard Wheels | 3,642.00 | 2,476.56 |
|--------------------------|----------|----------|

~ ~ **Selection 6 ~ Choose Rotation** ~ ~

| | | |
|------------------------------------|----------|----------|
| R500-205 Hydraulic Rotating option | 3,565.00 | 2,424.20 |
| R500-210 Manual Pivot Option | 741.00 | 503.88 |

~ ~ **Selection 7 ~ Choose Flow Option** ~ ~

| | | |
|---|----------|----------|
| R500-215 Drive Option 8.0 CU.IN. Motor | 1,665.00 | 1,132.20 |
| R500-220 Drive Option 15.0 CU.IN. Motor | 2,699.00 | 1,835.32 |
| R500-225 Drive Option 9.9 CU.IN. Motor | 2,545.00 | 1,730.60 |
| R500-230 Drive Option 19.0 CU.IN. Motor | 2,791.00 | 1,897.88 |
| R500-235 Drive Option 24.0 CU.IN. Motor | 2,881.00 | 1,959.08 |
| R500-240 Drive Option 12.5 CU.IN. Motor | 2,635.00 | 1,791.80 |
| Assembly | Net | 200.00 |

Use **this** flow chart to determine the proper Drive option

| GPM @2500psi | Motor size (cu. in.) | | | | |
|--------------|----------------------|-----|-----|-----|-----|
| | 8 | 9.9 | 15 | 19 | 24 |
| 18 | 213 | 168 | 112 | 90 | 69 |
| 20 | 237 | 189 | 125 | 101 | 77 |
| 22 | 263 | 208 | 138 | 112 | 85 |
| 25 | 299 | 238 | 157 | 126 | 98 |
| 27 | | 264 | 175 | 139 | 110 |
| 30 | | 285 | 188 | 152 | 119 |
| 35 | | | 221 | 178 | 136 |

Landscaping, levelling, seedbed prep – Target RPM from 175-260
 Large debris removal, rock windrowing – Target RPM from 110-140
 Sweeping – Target RPM 210



MASTER PRICE SHEET



Schulte Industries Ltd.

100 John Schulte Dr., Englefeld, SK. Canada, S0K 1N0
 Tel: 306-287-3715 Fax: 306-287-3355 Toll Free: 1-800-404-6044
 Web: www.Schulte.ca

Sourcewell - Road Right Of Way Maintenance Equipment
MACHINE PRICES AND SPECIFICATIONS



SMR-600 Multi Skid-steer Windrower/Landscape Rake

SPECIFICATIONS

| | | | |
|----------------------|-------------------|------------|----------------------|
| Weight (approximate) | 1600 lbs (725 kg) | Drum width | 73" (1.85m) |
| Transport width | 88" (2.23m) | Tires | 23" forklift (58 cm) |

~ ~ **Selection 1 ~ Choose a Basic Unit** ~ ~

| | | |
|---|---------------------|-----------------------|
| | Retail Price | Contract Price |
| R700-100 Skid-steer Windrower Base Unit | 10,258.00 | 6,975.44 |

~ ~ **Selection 2 ~ Choose One Correct Harness (With Hydraulic Rotating Opt only)** ~ ~

| | | |
|---|----------|----------|
| R500-315 Interface Harness, JCB/Takeuchi | 365.00 | 248.20 |
| R500-320 Interface Harness, Volvo | 365.00 | 248.20 |
| R500-325 Interface Harness, Kubota | 365.00 | 248.20 |
| R500-330 Interface Harness for CNH | 365.00 | 248.20 |
| R500-335 Interface Harness for Cat (14 pin) | 365.00 | 248.20 |
| R500-340 Interface Harness for JohnDeere | 365.00 | 248.20 |
| R500-345 Electric Harness With Switch Box | 903.00 | 614.04 |
| R500-350 Interface Harness for Bobcat | 2,796.00 | 1,901.28 |
| R500-355 CAT D-Series Adapter Harness | 466.00 | 316.88 |

~ ~ **Selection 3 ~ Choose Drum Configuration** ~ ~

| | | |
|--|----------|----------|
| R700-115 Standard Drum | 2,935.00 | 1,995.80 |
| R700-125 4 inch 450 BHN Steel Teeth <i>Choose Teeth Configuration</i> | 1,541.00 | 1,047.88 |

~ ~ **Selection 4 ~ Choose Mount** ~ ~

| | | |
|-------------------------------|----------|----------|
| R500-130 Standard Rigid Mount | 2,416.00 | 1,642.88 |
|-------------------------------|----------|----------|

~ ~ **Selection 5 ~ Choose Wheel Option (must pick)** ~ ~

| | | |
|--------------------------|----------|----------|
| R500-610 Standard Wheels | 3,642.00 | 2,476.56 |
|--------------------------|----------|----------|

~ ~ **Selection 6 ~ Choose Rotation** ~ ~

| | | |
|------------------------------------|----------|----------|
| R700-215 Hydraulic Rotating option | 3,550.00 | 2,414.00 |
| R500-210 Manual Pivot Option | 741.00 | 503.88 |

~ ~ **Selection 7 ~ Choose Flow Option** ~ ~

| | | |
|---|----------|------------|
| R500-215 Drive Option 8.0 CU.IN. Motor | 1,665.00 | 1,132.00 |
| R500-220 Drive Option 15.0 CU.IN. Motor | 2,699.00 | 1,835.32 |
| R500-225 Drive Option 9.9 CU.IN. Motor | 2,545.00 | 1,730.60 |
| R500-230 Drive Option 19.0 CU.IN. Motor | 2,791.00 | 1,897.88 |
| R500-235 Drive Option 24.0 CU.IN. Motor | 2,881.00 | 1,959.08 |
| R500-240 Drive Option 12.5 CU.IN. Motor | 2,635.00 | 1,791.80 |
| Assembly | | Net |
| | | 200.00 |

Use this flow chart to determine the proper Drive option

| GPM @2500psi | Motor size (cu. in.) | | | | |
|--------------|----------------------|-----|-----|-----|-----|
| | 8 | 9.9 | 15 | 19 | 24 |
| 18 | 213 | 168 | 112 | 90 | 69 |
| 20 | 237 | 189 | 125 | 101 | 77 |
| 22 | 263 | 208 | 138 | 112 | 85 |
| 25 | 299 | 238 | 157 | 126 | 98 |
| 27 | | 264 | 175 | 139 | 110 |
| 30 | | 285 | 188 | 152 | 119 |
| 35 | | | 221 | 178 | 136 |

Landscaping, levelling, seedbed prep – Target RPM from 175-260
 Large debris removal, rock windrowing – Target RPM from 110-140



MASTER PRICE SHEET



Schulte Industries Ltd.

100 John Schulte Dr., Englefeld, SK. Canada, S0K 1N0

Tel: 306-287-3715 Fax: 306-287-3355 Toll Free: 1-800-404-6044

Web: www.Schulte.ca

Sourcewell - Road Right Of Way Maintenance Equipment

MACHINE PRICES AND SPECIFICATIONS

RS320 'Jumbo' Rock Picker



PICKER FEATURES

- Hydraulic cylinders & hoses
- Grated buckets
- Extended hitch poles
- Pivoting hitch
- Safety chain

TRACTOR HYDRAULIC REQUIREMENTS

Rock pickers, hydraulically driven, **require closed center** dual remote outlets with a minimum of 12 gallons per minute flow at 1750 psi.

~ ~ **Selection 1 ~ Choose a Basic Unit** ~ ~

| | | | <i>Retail Price</i> | <i>Contract Price</i> |
|----|--------|--|---------------------|-----------------------|
| 1) | 90-100 | RS320 'Jumbo' Rock Picker, conveyer type, hydraulic drive, semi hi-lift, 4 batt, 3.2 cubic yard grated bucket c/w pivoting hitch, 16.5x16.1x10 Ply Tires | 59,683.00 | 40,584.44 |

~ ~ **Selection 2 ~ Extra Options** ~ ~

| | | | | |
|----|----------|--|--------|--------|
| 1) | S000-075 | Safety Light Kit | 999.00 | 679.32 |
| 2) | 90-250 | Hydraulic Swing Hitch (For RS320 Only) | 738.00 | 501.84 |
| | | Setup For Loading | Net | 250.00 |
| | | Setup For Towing | Net | 300.00 |

IMPORTANT: Safety Chain Kit & Safety Light Kit must be used at all time when moving equipment on any type of road.

PREDELIVERY SERVICE IS REQUIRED BY DEALER OR END USER



MASTER PRICE SHEET



Schulte Industries Ltd.

100 John Schulte Dr., Englefeld, SK. Canada, S0K 1N0

Tel: 306-287-3715 Fax: 306-287-3355 Toll Free: 1-800-404-6044

Web: www.Schulte.ca

Sourcewell - Road Right Of Way Maintenance Equipment

MACHINE PRICES AND SPECIFICATIONS

2500 Giant Rock Picker



PICKER FEATURES

- Hydraulic cylinders & hoses
- Grated buckets
- Extended hitch poles
- Pivoting hitch
- Safety chain

TRACTOR HYDRAULIC REQUIREMENTS

Rock pickers, hydraulically driven, **require closed center** dual remote outlets with a minimum of 12 gallons per minute flow at 1750 psi.

~ ~ Selection 1 ~ Choose a Basic Unit ~ ~

| | | <i>Retail Price</i> | <i>Contract Price</i> |
|----|--|---------------------|-----------------------|
| 1) | R100-001 2500 Giant Big Bucket Rock Picker, reel type, pivoting hitch, rock deflector, hydraulic drive, semi hi-lift, 16.5x16.1x10 Ply Tires | 35,677.00 | 24,260.36 |
| | <i>Choose one:</i> (2500 only) | | |
| a) | R100-190 Heavy Duty Grate and Reel Assembly, Narrow Space <i>c/w Replaceable Teeth, 1-1/2" Spacing</i> | 19,995.00 | 13,596.60 |
| b) | R100-215 Heavy Duty Grate and Reel Assembly, Wide Space <i>c/w Replaceable Teeth, 3-9/32" Spacing</i> | 17,149.00 | 11,661.32 |
| | <i>Choose One Required Option:</i> | | |
| a) | R400-140 Longer Bent Hitch Pole | 2,681.00 | 1,823.08 |
| | Pick one of the Following | | |
| a) | R100-265 Standard Hydraulics | 356.00 | 242.08 |
| b) | R100-270 Flow Control Kit | 793.00 | 539.24 |

~ ~ Selection 2 ~ Extra Options ~ ~

| | | | |
|----|--|------------|--------|
| 1) | S000-039 Safety Light Kit | 931.00 | 633.08 |
| 2) | R400-255 Hydraulic Swing Hitch (2500 Giant) | 557.00 | 378.76 |
| | Setup For Loading | Net | 250.00 |
| | Setup For Towing | Net | 300.00 |

IMPORTANT: Safety Chain Kit & Safety Light Kit must be used at all time when moving equipment on any type of road.



MASTER PRICE SHEET



Schulte Industries Ltd.

100 John Schulte Dr., Englefeld, SK. Canada, S0K 1N0

Tel: 306-287-3715 Fax: 306-287-3355 Toll Free: 1-800-404-6044

Web: www.Schulte.ca

Sourcewell - Road Right Of Way Maintenance Equipment

MACHINE PRICES AND SPECIFICATIONS

3500 Giant Rock Picker



PICKER FEATURES

- Hydraulic cylinders & hoses
- Grated buckets
- Extended hitch poles
- Pivoting hitch
- Safety chain

TRACTOR HYDRAULIC REQUIREMENTS

Rock pickers, hydraulically driven, **require closed center** dual remote outlets with a minimum of 12 gallons per minute flow at 1750 psi.

~ ~ Selection 1 ~ Choose a Basic Unit ~ ~

| | | | <i>Retail Price</i> | <i>Contract Price</i> |
|----|----------|--|---------------------|-----------------------|
| 1) | R350-100 | 3500 Giant Base Unit | 31,267.00 | 21,261.56 |
| | | <i>Choose one:</i> | | |
| | a) | R350-235 Contractor Heavy Duty Grate and Reel Assembly, <i>Narrow Space c/w Replaceable Teeth, 1-1/2" Spacing</i> | 26,196.00 | 17,813.28 |
| | c) | R350-225 Contractor Heavy Duty Grate and Reel Assembly, <i>Wide Space c/w Replaceable Teeth, 3-9/32" Spacing</i> | 21,572.00 | 14,668.96 |

~ ~ Selection 2 ~ Choose a Hitch Pole ~ ~

| | | | | |
|----|----------|---|----------|----------|
| 2) | R400-140 | Bent Hitch Pole | 2,681.00 | 1,823.08 |
| | | <i>Pick one of the Following:</i> | | |
| | a) | R100-265 Standard Hydraulics | 356.00 | 242.08 |
| | b) | R100-270 Hydraulics w/ Flow Control Kit | 793.00 | 539.24 |

MASTER PRICE SHEET



Schulte Industries Ltd.

100 John Schulte Dr., Englefeld, SK. Canada, S0K 1N0

Tel: 306-287-3715 Fax: 306-287-3355 Toll Free: 1-800-404-6044

Web: www.Schulte.ca



Sourcewell - Road Right Of Way Maintenance Equipment

MACHINE PRICES AND SPECIFICATIONS

3500 Giant Rock Picker

~ ~ Selection 3 ~ Wheel Options ~ ~

| | | | | |
|----|----------|---|----------|----------|
| 1) | R350-300 | Standard Wheel Option (16.5 x 16.1 x 10 Ply) | 4,762.00 | 3,238.16 |
| 2) | R350-350 | Larger Wheel Option (560/45 x 22.5, 152 D Load Index) | 8,951.00 | 6,086.68 |

~ ~ Selection 4 ~ Rock Deflector Options ~ ~

| | | | | |
|----|----------|--|--------|--------|
| 1) | R350-400 | Standard Side Rock Deflector <i>Order with R350-300 (Standard Wheel Option)</i> | 452.00 | 307.36 |
| 2) | R350-450 | Large Side Rock Deflector <i>Order with R350-350 (Larger Wheel Option)</i> | 505.00 | 343.40 |

~ ~ Selection 5 ~ Extra Options ~ ~

| | | | | |
|----|----------|-----------------------|----------|--------|
| 1) | R400-255 | Hydraulic Swing Hitch | 557.00 | 378.76 |
| 2) | S000-175 | Safety Light Kit | 1,012.00 | 688.16 |
| | | Setup For Loading | Net | 250.00 |
| | | Setup For Towing | Net | 300.00 |

IMPORTANT: Safety Chain Kit & Safety Light Kit must be used at all time when moving equipment on any type of road.



MASTER PRICE SHEET



Schulte Industries Ltd.

100 John Schulte Dr., Englefeld, SK. Canada, S0K 1N0
 Tel: 306-287-3715 Fax: 306-287-3355 Toll Free: 1-800-404-6044
 Web: www.Schulte.ca



Sourcewell - Road Right Of Way Maintenance Equipment

MACHINE PRICES AND SPECIFICATIONS

5000 Titan II Rock Picker

PICKER FEATURES

- Dumping height - 79" (2007 mm)
- Hopper capacity - 5 cu. yds. (3.82 m³)
- 450 BHN Steel teeth and T-iron tops for extra-long life
- Hydraulic Pivoting hitch
- Picks rocks - 2" - 27" (5cm - 69cm)
- Required horsepower -125 HP (93 kW)
- Required tractor hydraulic capacity at 4 remote outlets
12 GPM@2200PSI, 4 remote outlets
- Case Drain Required
- Recommended Reel Speed 36 rpm

~ ~ Selection 1 ~ Choose a Basic Unit ~ ~

| | | <i>Retail Price</i> | <i>Contract Price</i> |
|----------|--|---------------------|-----------------------|
| R801-100 | 5000 TITAN II Rock Picker 5 cu.yd. bucket, 6.5 ft Dump Height, Hydraulic Swing Hitch | 69,561.00 | 47,301.48 |
| R800-200 | Optional Rock Deflector | 616.00 | 418.88 |

~ ~ Selection 2 ~ Reel and Grates ~ ~

| | | | |
|----------|---|-----------|-----------|
| R801-200 | Grate and Reel c/w Narrow 1-1/2" spacing, 450 BHN Steel Teeth and T-iron | 39,531.00 | 26,881.08 |
| R801-225 | Grate and Reel c/w Wide 3 - 9/32" spacing, 450 BHN Steel Teeth and T-iron | 34,910.00 | 23,738.80 |

~ ~ Selection 3 ~ Reel and Grates ~ ~

| | | | |
|----------|-----------------------------|------------|-----------------|
| R800-250 | Flow Control Kit | 434.00 | 295.12 |
| R800-800 | Containerized/Racked | Net | 1,500.00 |
| R800-810 | Set up for loading | Net | 400.00 |
| | Setup For Towing | Net | 600.00 |

PREDELIVERY SERVICE IS REQUIRED BY DEALER OR END USER



MASTER PRICE SHEET



Schulte Industries Ltd.

100 John Schulte Dr., Englefeld, SK. Canada, S0K 1N0

Tel: 306-287-3715 Fax: 306-287-3355 Toll Free: 1-800-404-6044

Web: www.Schulte.ca

Sourcewell - Road Right Of Way Maintenance Equipment

MACHINE PRICES AND SPECIFICATIONS

SPARTAN RWP-1935 PICKER / WINDROWER COMBO



PICKER FEATURES

- Dumping height of over 8-1/2' (2.6m)
- Hopper capacity - 3.5 cu. yds. (2.68 m³)
- Hard surfaced teeth & batt reels for extra-long life
- Adjustable working widths of 16' - 19' (4.8m - 5.8m)
- Picks rocks - 2" - 27" (5cm - 69cm)
- Adjustable working depths down to 4.25" (11 cm)
- Separate hydraulic adjustment of windrower & reel speeds
- Minimum horsepower -125 HP (93 kW)
- Required tractor hydraulic capacity - 16 GPM with two remotes
- Recommended reel speed - 40 rpm
- Case drain required
- PTO required to run hydraulic pump that is available in 3 standard shaft sizes

~ ~ Selection 1 ~ Choose a Basic Unit ~ ~

| | | Retail Price | Contract Price |
|----------|---|---------------------|-----------------------|
| R190-100 | RWP-1935 Rock Picker / Rock Windrower Combo Base Unit | 171,899.00 | 116,891.32 |

~ ~ Selection 2 ~ Hydraulic Pump Options ~ ~

| | | | |
|----------|---|----------|----------|
| R190-300 | 540 RPM Hydraulic Pump, 1-3/8" 6 Spline | 5,746.00 | 3,907.28 |
| R190-310 | 1000 RPM Hydraulic Pump, 1-3/8" 21 Spline | 6,139.00 | 4,174.52 |
| R190-320 | 1000 RPM Hydraulic Pump, 1-3/4" 20 Spline | 7,606.00 | 5,172.08 |

~ ~ Selection 3 ~ Options ~ ~

| | | | |
|----------|--|--------|--------|
| R190-400 | Wheel Spacer Kit <i>(Adds 3" to the dump height)</i> | 539.00 | 366.52 |
|----------|--|--------|--------|

| | | |
|---------------------------|------------|-----------------|
| Setup For Shipping | Net | 2,600.00 |
|---------------------------|------------|-----------------|

PREDELIVERY SERVICE IS REQUIRED BY DEALER OR END USER





United States Price List Index

Schulte Industries Ltd.

100 John Schulte Dr., Englefeld, SK. Canda, S0K 1N0

Tel: 306-287-3715 Fax: 306-287-3355 Toll Free: 1-800-404-6044

Web: www.Schulte.ca



Sourcewell - Road Right Of Way Maintenance Equipment



Click on this symbol to
return to this index page

Snow Blowers

SDX-144 Snow Blower

RDX-117 Snow Blower

SDX-117 Snow Blower

SDX-102 Snow Blower

FM-350 Front Mount 3pt Hitch Frame

FM-115 Front Mount 3pt Hitch Frame

SBX-87 Skid Steer Snow Blower

SBX-87 3pt Snow Blower

Ground Maintenance

SRW-1400/H - 14 ft Rock Windrower

SRW-1000 - 10 ft Rock Windrower

SRW-800 - 8 ft Rock Windrower

SMR-800 - Skid-Steer 8 ft Landscape Rake/Sweeper

SMR-600 - Skid-Steer 6 ft Landscape Rake/Sweeper

RS320 Jumbo - RS320 Jumbo Rock Picker

2500 Giant - 2500 Giant Rock Picker

3500 Giant - 3500 Giant Rock Picker

5000 Titan II - 5000 Titan II Rock Picker

SPARTAN RWP-1935 - Rock Picker / Windrower Combo

MASTER PRICE SHEET



Schulte Industries Ltd.

100 John Schulte Dr., Englefeld, SK. Canada, S0K 1N0

Tel: 306-287-3715 Fax: 306-287-3355 Toll Free: 1-800-404-6044

Web: www.Schulte.ca



Sourcewell - Road Right Of Way Maintenance Equipment

MACHINE PRICES AND SPECIFICATIONS

SDX-144 SNOW BLOWER

SDX-144 Snow Blower Specs:

| | |
|---------------------------|---|
| Cutting Width: 144" | Adjustable, replaceable skid shoes |
| Tractor HP: 180 - 350 HP | Replaceable & reversible Cutting Blade |
| Cutting Height: 45.5" | Gear Driven Rotator |
| Lower Auger Diameter: 23" | High molecular plastic chute rotating surface |
| Upper Auger Diameter: 14" | Double chute deflector on HD and Truck loading chutes |
| Fan Diameter: 38" | Serrated Tooth Top & Bottom Augers |
| Fan Type: 5 Paddle | Capacity - Dry Snow / Wet Snow |
| Drive: 1000 RPM | 762 tons per hr / 2394 per hr |

~ ~ Selection 1 ~ Choose a Basic Unit ~ ~

| | | <i>Retail Price</i> | <i>Contract Price</i> |
|----------|----------------------------|---------------------|-----------------------|
| B144-100 | SDX-144 (144" Snow Blower) | 26,130.00 | 17,768.40 |

~ ~ Selection 2 ~ Choose a Gear Box ~ ~

| | | | |
|-----------|--|----------|----------|
| 330-655WG | Standard Gearbox (<i>tractors with cw pto rotation</i>) | 5,356.00 | 3,642.08 |
| 330-655R | Non-standard Gearbox (<i>tractors with ccw pto rotation</i>) | 5,580.00 | 3,794.40 |

~ ~ Selection 3 ~ Choose a Power Shaft ~ ~

| | | | |
|-----------|--------------------------------|----------|--------|
| 340-946WG | 1-3/8 Z21 (size 9) for SDX-144 | 1,445.00 | 982.60 |
| 340-947WG | 1-3/4 Z20 (size 9) for SDX-144 | 1,445.00 | 982.60 |

~ ~ Selection 4 ~ Category 4 Hitch ~ ~

| | | | |
|----------|--------------------------------------|--------|--------|
| B144-440 | Category 4 Hitch (<i>Optional</i>) | 295.00 | 200.60 |
|----------|--------------------------------------|--------|--------|

MASTER PRICE SHEET



Schulte Industries Ltd.

100 John Schulte Dr., Englefeld, SK. Canada, S0K 1N0

Tel: 306-287-3715 Fax: 306-287-3355 Toll Free: 1-800-404-6044

Web: www.Schulte.ca



Sourcewell - Road Right Of Way Maintenance Equipment

MACHINE PRICES AND SPECIFICATIONS

SDX-144 SNOW BLOWER

~ ~ Selection 5 ~ Choose a Chute kit ~ ~

| | | | |
|--|--|----------|-----------------|
| B110-270 | Heavy Duty Chute Kit with Dbl Chute Deflector | 2,021.00 | 1,374.28 |
| B840-250 | Cylinder Kit for B110-270 (Required) | 508.00 | 345.44 |
| B110-280 | Truck Loading Chute Kit with Dbl Chute Deflector | 2,750.00 | 1,870.00 |
| B110-260 | Cylinder Kit for B110-280 (Required) | 538.00 | 365.84 |
| <u>NOTE:</u> Cylinder kits are complete with 2" x 6" cylinder & hoses | | | |
| B117-220 | Folding Truck Loading Chute | 4,713.00 | 3,204.84 |
| <u>NOTE:</u> Hoses & Two Cylinders Included in B117-220 | | | |

| | | |
|----------|-----|---------------|
| Assembly | Net | 275.00 |
|----------|-----|---------------|



MASTER PRICE SHEET



Schulte Industries Ltd.

100 John Schulte Dr., Englefeld, SK. Canada, S0K 1N0

Tel: 306-287-3715 Fax: 306-287-3355 Toll Free: 1-800-404-6044

Web: www.Schulte.ca



Sourcewell - Road Right Of Way Maintenance Equipment

MACHINE PRICES AND SPECIFICATIONS

RDX-117 SNOW BLOWER

RDX-117 Snow Blower Specs:

| | |
|---------------------------|---|
| Cutting Width: 117" | Adjustable, replaceable skid shoes |
| Tractor HP: 140 - 220 HP | Replaceable & reversible Cutting Blade |
| Cutting Height: 45.5" | Gear Driven Rotator |
| Lower Auger Diameter: 23" | High molecular plastic chute rotating surface |
| Upper Auger Diameter: 14" | Double chute deflector on HD and Truck loading chutes |
| Fan Diameter: 38" | Capacity - Dry Snow / Wet Snow |
| Fan Type: 5 Paddle | 762 tons per hr / 2394 per hr |
| Drive: 1000 RPM | |

~ ~ Selection 1 ~ Choose a Basic Unit ~ ~

| | | <i>Retail Price</i> | <i>Contract Price</i> |
|----------|----------------------------|---------------------|-----------------------|
| B118-000 | RDX-117 (117" Snow Blower) | 28,252.00 | 19,211.36 |

~ ~ Selection 2 ~ Choose a Gear Box ~ ~

| | | | |
|-----------|--|----------|----------|
| 330-655WG | Standard Gearbox (<i>tractors with cw pto rotation</i>) | 5,356.00 | 3,642.08 |
| 330-655R | Non-standard Gearbox (<i>tractors with ccw pto rotation</i>) | 5,580.00 | 3,794.40 |

~ ~ Selection 3 ~ Choose a Power Shaft ~ ~

| | | | |
|-----------|--|----------|--------|
| 340-926WG | 1-3/4 Z20 (size 9) for SDX-117 / RDX-117 | 1,235.00 | 839.80 |
| 340-925WG | 1-3/8 Z21 (size 9) for SDX-117 / RDX-117 | 1,235.00 | 839.80 |

NOTE: Do not order above shaft if going on a FM350

MASTER PRICE SHEET



Schulte Industries Ltd.

100 John Schulte Dr., Englefeld, SK. Canada, S0K 1N0

Tel: 306-287-3715 Fax: 306-287-3355 Toll Free: 1-800-404-6044

Web: www.Schulte.ca



Sourcewell - Road Right Of Way Maintenance Equipment

MACHINE PRICES AND SPECIFICATIONS

RDX-117 SNOW BLOWER

~ ~ Selection 4 ~ Choose a Chute kit ~ ~

| | | | |
|--|--|----------|----------|
| B110-270 | Heavy Duty Chute Kit with Dbl Chute Deflector | 2,021.00 | 1,374.28 |
| B840-250 | Cylinder Kit for B110-270 (Required) | 508.00 | 345.44 |
| B110-280 | Truck Loading Chute Kit with Dbl Chute Deflector | 2,750.00 | 1,870.00 |
| B110-260 | Cylinder Kit for B110-280 (Required) | 538.00 | 365.84 |
| <u>NOTE:</u> Cylinder kits are complete with 2" x 6" cylinder & hoses | | | |
| B117-220 | Folding Truck Loading Chute | 4,713.00 | 3,204.84 |
| <u>NOTE:</u> Hoses & Two Cylinders Included in B117-220 | | | |
| B890-300WG | Gauge Wheels with Tapered Roller Bearings | 2,147.00 | 1,459.96 |
| | Assembly | Net | 225.00 |



MASTER PRICE SHEET



Schulte Industries Ltd.

100 John Schulte Dr., Englefeld, SK. Canada, S0K 1N0

Tel: 306-287-3715 Fax: 306-287-3355 Toll Free: 1-800-404-6044

Web: www.Schulte.ca



Sourcewell - Road Right Of Way Maintenance Equipment

MACHINE PRICES AND SPECIFICATIONS

SDX-117 SNOW BLOWER

SDX-117 Snow Blower Specs:

Cutting Width: 117"

Tractor HP: 140 - 220 HP

Cutting Height: 45.5"

Lower Auger Diameter: 23"

Upper Auger Diameter: 14"

Fan Diameter: 38"

Fan Type: 5 Paddle

Drive: 1000 RPM

Adjustable, replaceable skid shoes

Replaceable & reversible Cutting Blade

Gear Driven Rotator

High molecular plastic chute rotating surface

Double chute deflector on HD and Truck loading chutes

Capacity - Dry Snow / Wet Snow

762 tons per hr / 2394 per hr

~ ~ Selection 1 ~ Choose a Basic Unit ~ ~

| | | <i>Retail Price</i> | <i>Contract Price</i> |
|----------|----------------------------|---------------------|-----------------------|
| B117-000 | SDX-117 (117" Snow Blower) | 21,830.00 | 14,844.40 |

~ ~ Selection 2 ~ Choose a Gear Box ~ ~

| | | | |
|-----------|--|----------|-----------------|
| 330-655WG | Standard Gearbox (<i>tractors with cw pto rotation</i>) | 5,356.00 | 3,642.08 |
| 330-655R | Non-standard Gearbox (<i>tractors with ccw pto rotation</i>) | 5,580.00 | 3,794.40 |

~ ~ Selection 3 ~ Choose a Power Shaft ~ ~

| | | | |
|-----------|--|----------|---------------|
| 340-926WG | 1-3/4 Z20 (size 9) for SDX-117 / RDX-117 | 1,235.00 | 839.80 |
| 340-925WG | 1-3/8 Z21 (size 9) for SDX-117 / RDX-117 | 1,235.00 | 839.80 |

NOTE: Do not order above shaft if going on a FM350

Instead, order from FM350 price sheet

MASTER PRICE SHEET



Schulte Industries Ltd.

100 John Schulte Dr., Englefeld, SK. Canada, S0K 1N0

Tel: 306-287-3715 Fax: 306-287-3355 Toll Free: 1-800-404-6044

Web: www.Schulte.ca



Sourcewell - Road Right Of Way Maintenance Equipment

MACHINE PRICES AND SPECIFICATIONS

SDX-117 SNOW BLOWER

~ ~ **Selection 4 ~ Choose a Chute kit ~ ~**

| | | | |
|--|--|----------|-----------------|
| B110-270 | Heavy Duty Chute Kit with Dbl Chute Deflector | 2,021.00 | 1,374.28 |
| B840-250 | Cylinder Kit for B110-270 (Required) | 508.00 | 345.44 |
| B110-280 | Truck Loading Chute Kit with Dbl Chute Deflector | 2,750.00 | 1,870.00 |
| B110-260 | Cylinder Kit for B110-280 (Required) | 538.00 | 365.84 |
| <u>NOTE:</u> Cylinder kits are complete with 2" x 6" cylinder & hoses | | | |
| B117-220 | Folding Truck Loading Chute | 4,713.00 | 3,204.84 |
| <u>NOTE:</u> Hoses & Two Cylinders Included in B117-220 | | | |
| B890-300WG | Gauge Wheels with Tapered Roller Bearings | 2,147.00 | 1,459.96 |
| | Assembly | Net | 225.00 |



MASTER PRICE SHEET



Schulte Industries Ltd.

100 John Schulte Dr., Englefeld, SK. Canada, S0K 1N0

Tel: 306-287-3715 Fax: 306-287-3355 Toll Free: 1-800-404-6044

Web: www.Schulte.ca



Sourcewell - Road Right Of Way Maintenance Equipment

MACHINE PRICES AND SPECIFICATIONS

SDX-102 SNOW BLOWER

SDX-102 Snow Blower Specs:

| | |
|------------------------|---------------------------------------|
| Cutting Width: 102" | Adjustable, replacable skid shoes |
| Drive: 540 or 1000 RPM | Replaceable Cutting Blade |
| Cutting Height: 35" | Gear Driven Rotator |
| Overall Height: 96" | Hydraulic Chute Rotation |
| Auger Diameter: 23" | Capacity Dry Snow/Wet Snow |
| Fan Diameter: 30" | 388 Tons per hr / 1222 tons per hr |
| Fan Type: 4 Paddle | Tractor HP: 85 - 140 HP (63 - 104 kw) |

~ ~ Selection 1 ~ Choose a Basic Unit ~ ~

| | | <i>Retail Price</i> | <i>Contract Price</i> |
|----------|----------------------------------|---------------------|-----------------------|
| B102-000 | SDX102 Standard Drum Snow Blower | 15,426.00 | 10,489.68 |

~ ~ Selection 2 ~ Choose a Power Shaft ~ ~

| | | | |
|-----------|--|----------|----------|
| 340-924WG | Size 9 Heavy Duty PTO Shaft <i>540 RPM</i> | 1,235.00 | 839.80 |
| 340-927WG | Size 9 Heavy Duty PTO Shaft (for TV-145 Engine End) <i>540 RPM</i> | 1,109.00 | 754.12 |
| | <i>Optional Gear Gbox</i> | | |
| B102-175 | 1000 RPM Gear Box STANDARD CW Rotation | 1,938.00 | 1,317.84 |
| B102-175R | 1000 RPM Gear Box CCW Rotation | 2,230.00 | 1,516.40 |
| | <i>Power Shaft for 1000 RPM Gear Box</i> | | |
| 340-928WG | 1-3/8 21 Spline shaft 1000 RPM | 1,340.00 | 911.20 |

NOTE: Do not order above shaft if going on a FM350 or FM115

Instead, order from FM350 price sheet

~ ~ Selection 3 ~ Choose a Chute Kit ~ ~

| | | | |
|----------|---|----------|----------|
| B110-270 | Heavy Duty Chute Kit with Dbl Chute Deflector | 2,021.00 | 1,374.28 |
| B840-250 | Cylinder Kit for B110-270 (Required) | 508.00 | 345.44 |
| B110-280 | Truck Loading Chute Kit with Dbl Chute Deflector | 2,750.00 | 1,870.00 |
| B110-260 | Cylinder Kit for B110-280 (Required) | 538.00 | 365.84 |
| | NOTE: Cylinder kits are complete with 2" x 6" cylinder & hoses | | |
| B102-250 | Folding Truck Loading Chute | 4,744.00 | 3,225.92 |

NOTE: Hoses & Two Cylinders Included in B102-250

MASTER PRICE SHEET



Schulte Industries Ltd.

100 John Schulte Dr., Englefeld, SK. Canada, S0K 1N0

Tel: 306-287-3715 Fax: 306-287-3355 Toll Free: 1-800-404-6044

Web: www.Schulte.ca



Sourcewell - Road Right Of Way Maintenance Equipment

MACHINE PRICES AND SPECIFICATIONS

SDX-102 SNOW BLOWER

~ ~ Selection 4 ~ Choose a Extra Options ~ ~

| | | |
|--|----------|-----------------|
| B890-300WG Gauge Wheels with Tapered Roller Bearings | 2,147.00 | 1,459.96 |
| | Assembly | Net |
| | | 150.00 |





MASTER PRICE SHEET

Schulte Industries Ltd.

100 John Schulte Dr., Englefeld, SK. Canada, S0K 1N0

Tel: 306-287-3715 Fax: 306-287-3355 Toll Free: 1-800-404-6044

Web: www.Schulte.ca



Sourcewell - Road Right Of Way Maintenance Equipment

MACHINE PRICES AND SPECIFICATIONS

FM-350 Front Mount 3pt Hitch Frame

FM-350 Specs:

- Tractor HP: 85 HP - 250 HP
- Adjustment: Accommodates tractors between 151" and 211" measured from mount plate to drawbar pin
- Nominal Ground Clearance - 13" depending on tractor installation
- Nominal Lift Range - 18"
- Weight - 1650 lbs
- Tractor PTO - 1000 rpm for SDX-117 and SDX-102
540 rpm for SDX-102 only
- Lift Capacity : 5000 lbs

~ ~ Selection 1 ~ Choose a Basic Unit ~ ~

| | | Retail Price | Contract Price |
|----------|---|--------------|----------------|
| F350-100 | FM-350 Front Mount Frame (NO Driveline Package) <i>Used for SV 3pt V-BLADE (must choose for all attachments)</i> <i>Includes 2 hydraulic banks for operation</i> | 10,087.00 | 6,859.16 |
| F350-200 | Driveline package (Used for Snow Blowers) | 6,584.00 | 4,477.12 |

~ ~ Selection 2 ~ Choose Gear Box ~ ~

| | | | |
|----------|--|----------|----------|
| F250-310 | 1:1 Rear Gear Box <i>Select when connecting a 1000 RPM PTO tractor to a SDX-117 or RDX-117 or when connecting a 540 RPM PTO tractor to a SDX-102 or RDX-102 snow blower</i> | 3,345.00 | 2,274.60 |
| F250-300 | 1000 to 540 RPM Rear Reduction Gearbox <i>Select when connecting a 1000 RPM PTO tractor to a SDX-102 or RDX-102</i> | 3,345.00 | 2,274.60 |

~ ~ Selection 3 ~ Choose REAR TRACTOR SHAFT ~ ~

NOTE: Power delivered from a 1,000 RPM tractor only

| | | | |
|-----------|--|----------|--------|
| 340-662WG | 1-3/8 Z21 for SDX-102 / RDX-102 | 865.00 | 588.20 |
| 340-663WG | 1-3/4 Z20 for SDX-102 / RDX-102 | 865.00 | 588.20 |
| 340-925WG | 1-3/8 Z21 (Size 9) for SDX-117 / RDX-117 | 1,235.00 | 839.80 |
| 340-926WG | 1-3/4 Z20 (size 9) for SDX-117 / RDX-117 | 1,235.00 | 839.80 |

NOTE: Power delivered from a 540 RPM tractor only

| | | | |
|-----------|--------------------------------|----------|--------|
| 340-924WG | 1-3/8 Z6 for SDX-102 / RDX-102 | 1,235.00 | 839.80 |
|-----------|--------------------------------|----------|--------|



MASTER PRICE SHEET

Schulte Industries Ltd.

100 John Schulte Dr., Englefeld, SK. Canada, S0K 1N0

Tel: 306-287-3715 Fax: 306-287-3355 Toll Free: 1-800-404-6044

Web: www.Schulte.ca



Sourcewell - Road Right Of Way Maintenance Equipment

MACHINE PRICES AND SPECIFICATIONS

FM-350 Front Mount 3pt

Hitch Frame

~ ~ Selection 4 ~ Choose Hydraulic Bank ~ ~

| | | | |
|-----------------|--|--------|---------------|
| F300-410 | Hydraulic Bank and Mount, Single <i>Required for drum rotation on RDX-102 / RDX-117</i> | 470.00 | 319.60 |
|-----------------|--|--------|---------------|

~ ~ Selection 5 ~ Choose Options ~ ~

Tractor Mount

| | | |
|--|--------|---------------|
| <i>*Please contact us for tractor mount options & availability</i> | 750.00 | 510.00 |
|--|--------|---------------|

| | | |
|----------|-----|---------------|
| Assembly | Net | 100.00 |
|----------|-----|---------------|





MASTER PRICE SHEET

Schulte Industries Ltd.

100 John Schulte Dr., Englefeld, SK. Canada, S0K 1N0

Tel: 306-287-3715 Fax: 306-287-3355 Toll Free: 1-800-404-6044

Web: www.Schulte.ca



Sourcewell - Road Right Of Way Maintenance Equipment

MACHINE PRICES AND SPECIFICATIONS

FM-115 Front Mount 3pt Hitch Frame

FM-115 Specs:

Tractor HP: Max. 115 hp (86kw)

Tractor HP: Min. 55hp(41kw) for SDX-840, 85hp (63kw)for SDX-102, RDX-102

Tractor Hydraulic Requirement - 3 remote circuits with a minimum total hydraulic output of 10 GPM at 1200 PSI.rotating drum.
An additional circuit is required if the snow blower has a rotating drum (RDX-102).

Tractor PTO - 540 RPM

Lift Capacity: Maximum - 5000 lbs (1162 KG)

Adjustability - Fits tractors between 111-1/2" and 164-1/2" measured the front mount plate to the drawbar pin

Normal Lift Range - 18"

Nominal Ground Clearance - 10" depending on tractor installation

Approximate Weight - 1400 lbs (636 KG)

~ ~ Selection 1 ~ Choose a Basic Unit ~ ~

| | | Retail Price | Contract Price |
|------------------|--|---------------------|-----------------------|
| F115-100 | FM-115 Front Mount Frame (NO Driveline Package) | 8,329.00 | 5,663.72 |
| F115-200 | <i>Driveline package (Used for Snow Blowers)</i> | 6,443.00 | 4,381.24 |
| 340-924WG | 1-3/8 Z6 (Size 9) for RDX-102 | 1,235.00 | 839.80 |
| | Tractor Mount | 750.00 | 510.00 |
| | Assembly | Net | 100.00 |



MASTER PRICE SHEET



Schulte Industries Ltd.

100 John Schulte Dr., Englefeld, SK. Canada, S0K 1N0

Tel: 306-287-3715 Fax: 306-287-3355 Toll Free: 1-800-404-6044

Web: www.Schulte.ca



Sourcewell - Road Right Of Way Maintenance Equipment

MACHINE PRICES AND SPECIFICATIONS

SBX-87 Skid Steer SNOW BLOWERS

SBX Series Snow blower Specs:

Cutting Widths: Replaceable Cutting Blade
 SBX-87 87"(221cm) Adjustable, replacable skid shoes

Standard Skid Steer Mounting Plate and electrical harnesses available for various skid steer moc

~ ~ Selection 1 ~ Choose a Basic Unit ~ ~

| | | <i>Retail Price</i> | <i>Contract Price</i> |
|----------|---|---------------------|-----------------------|
| B870-100 | SBX-87 Base Unit <i>Includes Hydraulic Rotator and Deflection</i> | 12,099.00 | 8,227.32 |

~ ~ Selection 2 ~ Choose Motor Mount Attachment Plate & Valve Block ~ ~

| | | | |
|----------|---|----------|----------|
| B750-300 | <u>Required</u> Mount Kit | 1,249.00 | 849.32 |
| B750-600 | <u>Required</u> Skid Steer Attachment plate | 1,030.00 | 700.40 |
| B750-400 | <u>Required</u> Hydraulic Valve Block | 4,012.00 | 2,728.16 |

~ ~ Selection 3 ~ Choose Hydraulics and Harness Assembly ~ ~

| | | | |
|----------|---|----------|----------|
| R500-345 | Control Box Interface <i>(Choose if Brand isn't listed below)</i> | 758.00 | 515.44 |
| R500-350 | Bobcat Interface Harness | 2,307.00 | 1,568.76 |
| R500-330 | CNH/Mustang/Gehl Harness Assembly | 295.00 | 200.60 |
| R500-335 | Cat 14 Harness Assembly | 295.00 | 200.60 |
| R500-340 | John Deere Harness Assembly | 295.00 | 200.60 |
| R500-325 | Kubota Harness Assembly | 295.00 | 200.60 |
| R500-315 | JCB, Takeuchi, Volvo Harness Assembly | 295.00 | 200.60 |
| R500-355 | CAT D-Series Adapter Harness | 388.00 | 263.84 |

MASTER PRICE SHEET



Schulte Industries Ltd.

100 John Schulte Dr., Englefeld, SK. Canada, S0K 1N0

Tel: 306-287-3715 Fax: 306-287-3355 Toll Free: 1-800-404-6044

Web: www.Schulte.ca



Sourcewell - Road Right Of Way Maintenance Equipment

MACHINE PRICES AND SPECIFICATIONS

SBX-87 Skid Steer SNOW BLOWERS

~ ~ Selection 4 ~ Choose Motor to Match Flow ~ ~

| | | | |
|-----------|---|----------|-----------------|
| 116-214WG | Hydraulic Motor, 6.2 cu. in. For 15-19 GPM Flow | 1,320.00 | 897.60 |
| 116-902WG | Hydraulic Motor,8.0 cu. in. For 20-24 GPM Flow | 1,460.00 | 992.80 |
| 116-903WG | Hydraulic Motor, 9.6 cu. in. For 25-29 GPM Flow | 1,514.00 | 1,029.52 |
| 116-904WG | Hydraulic Motor,11.9 cu. in. For 30-35 GPM Flow | 1,617.00 | 1,099.56 |

| | | |
|----------|-----|---------------|
| Assembly | Net | 350.00 |
|----------|-----|---------------|



MASTER PRICE SHEET



Schulte Industries Ltd.

100 John Schulte Dr., Englefeld, SK. Canada, S0K 1N0

Tel: 306-287-3715 Fax: 306-287-3355 Toll Free: 1-800-404-6044

Web: www.Schulte.ca



Sourcewell - Road Right Of Way Maintenance Equipment

MACHINE PRICES AND SPECIFICATIONS

SBX-87 3pt SNOW BLOWERS

SBX 3 PT Snow Blower Specs:

Cutting Widths:

SBX-87 87"(221cm)

540 RPM - cat 1 hitch

Replaceable Cutting Blade

Adjustable, replacable skid shoes

Improved larger chute design

~ ~ Selection 1 ~ Choose a Basic Unit ~ ~

| | | Retail Price | Contract Price |
|----------|---|---------------------|-----------------------|
| B870-100 | SBX-87 Base Unit <i>Includes Hydraulic Rotator and Deflection</i> | 12,099.00 | 8,227.32 |

~ ~ Selection 2 ~ Choose 3PT HITCH (important: not optional) ~ ~

| | | | |
|----------|--------------------------------|----------|-----------------|
| B750-200 | Required 3 PT Hitch Kit | 2,031.00 | 1,381.08 |
| | Assembly | Net | 100.00 |



MASTER PRICE SHEET



Schulte Industries Ltd.

100 John Schulte Dr., Englefeld, SK. Canada, S0K 1N0

Tel: 306-287-3715 Fax: 306-287-3355 Toll Free: 1-800-404-6044

Web: www.Schulte.ca



Sourcewell - Road Right Of Way Maintenance Equipment

MACHINE PRICES AND SPECIFICATIONS

- SRW-1400 - Mechanical Rock Windrower**
- SRW-1400H- Hydraulic Drive Rock Windrower**

SPECIFICATIONS

- Horsepower Required --- 40hp to 150hp, 540 rpm
- Maximum Ground Speed -- 5mph
- Recommended Ground Speed -- 2mph
- Drum Speed -- 117 rpm @ 540 input (Mechanical)
- Tires - ST205 90-15, D Load Range
- Transport Width -- 7.75'
- Transport Length -- 235"
- Hydraulic Drive Requires 15 GPM/ 57 LPM Hydraulic Flow

HOW TO ORDER: You must select from 1, 2 and 3 to receive a complete rock windrower.
To receive additional options, choose from selection 4.

~ ~ Selection 1 ~ Choose a Basic Unit ~ ~

| | | | <i>Retail Price</i> | <i>Contract Price</i> |
|----|----------|------------------------------|---------------------|-----------------------|
| 1) | R210-100 | SRW1400 Base Unit (Required) | 26,653.00 | 18,124.04 |

~ ~ Selection 2 ~ Choose Drive System ~ ~

| | | | | |
|----|----------|---|----------|----------|
| 1) | R210-750 | Mechanical Drive System (540 RPM 40-150 HP) OR | 5,096.00 | 3,465.28 |
| 2) | R210-700 | Hydraulic Drive System (15 GPM Flow Minimum Needed) | 3,246.00 | 2,207.28 |

~ ~ Selection 3 ~ Choose Drum ~ ~

| | | | | |
|----|----------|--|-----------|----------|
| 1) | R210-180 | SRW1400 Drum With Bolt On Teeth (Required) | 12,098.00 | 8,226.64 |
|----|----------|--|-----------|----------|

~ ~ Selection 4 ~ Hydraulic Cylinder Kit ~ ~

| | | | | |
|----|----------|--|----------|--------|
| 1) | R210-270 | Complete Hydraulic Cylinder Kit consisting of (2) 3 x 8 hydraulic cylinders c/w depth stops, steel lines, hoses and fittings (required to operate windrower) | 1,220.00 | 829.60 |
|----|----------|--|----------|--------|

PREDELIVERY SERVICE IS REQUIRED BY DEALER OR END USER

MASTER PRICE SHEET



Schulte Industries Ltd.

100 John Schulte Dr., Englefeld, SK. Canada, S0K 1N0

Tel: 306-287-3715 Fax: 306-287-3355 Toll Free: 1-800-404-6044

Web: www.Schulte.ca



Sourcewell - Road Right Of Way Maintenance Equipment

MACHINE PRICES AND SPECIFICATIONS

SRW-1400 - Mechanical Rock Windrower
SRW-1400H- Hydraulic Drive Rock Windrower

~ ~ **Selection 5 ~ Extra Options** ~ ~

| | | | | |
|-----------------|----------|--|----------|----------|
| 1) | R200-220 | CE Shield Kit for SRW1400 | 3,660.00 | 2,488.80 |
| 2) | S000-065 | Safety Light Kit for SRW1400 | 841.00 | 571.88 |
| 3) | R210-200 | High Speed Sprocket (for gravel reclamation) | 573.00 | 389.64 |
| Assembly Charge | | | Net | 500.00 |

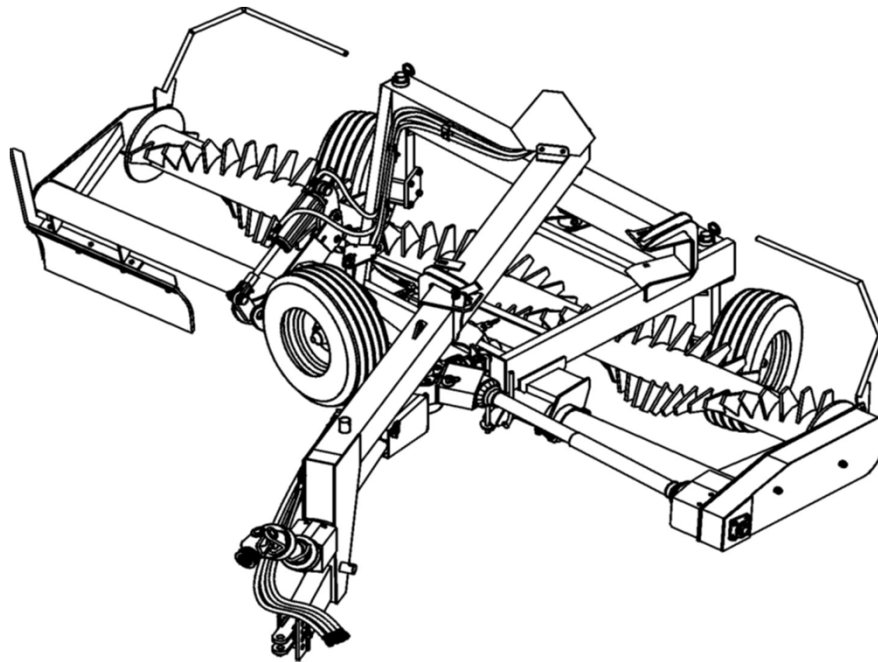

PREDELIVERY SERVICE IS REQUIRED BY DEALER OR END USER



MASTER PRICE SHEET



Schulte Industries Ltd.

100 John Schulte Dr., Englefeld, SK. Canada, S0K 1N0

Tel: 306-287-3715 Fax: 306-287-3355 Toll Free: 1-800-404-6044

Web: www.Schulte.ca



Sourcewell - Road Right Of Way Maintenance Equipment

MACHINE PRICES AND SPECIFICATIONS

SRW-1000 Rock Windrower

SPECIFICATIONS

- Horsepower Required --- 40hp to 150hp 30-112KW), 540rpm
- Maximum Ground Speed -- 5mph (8kph)
- Recommended Ground Speed -- 2mph (3kph)
- Drum Speed -- 117 rpm @ 540 input
- Drum Width -- 10 ft (3.05 m)
- Tires - Forklift Tire 6.5 x 10, 10 ply
- Transport Width -- 7.75'
- Transport Length -- 235"
- Weight -- 2660 lbs (1206 kg)

~ ~ Selection 1 ~ Choose a Basic Unit ~ ~

| | | <i>Retail Price</i> | <i>Contract Price</i> |
|----------|--|---------------------|-----------------------|
| R900-100 | SWR1000 Standard 10 ft unit | 21,291.00 | 14,477.88 |
| R900-200 | Safety Light Kit (Required in North America) | 851.00 | 578.68 |

~ ~ Selection 2 ~ Choose Drive System ~ ~

| | | | |
|----------|-----------------------------------|----------|----------|
| R900-650 | Mechanical Drive System OR | 4,598.00 | 3,126.64 |
| R900-600 | Hydraulic Drive System | 2,579.00 | 1,753.72 |

~ ~ Selection 3 Choose Tires ~ ~

| | | | |
|-----------|--|--------|--------|
| 210-175WG | Forklift Tire 6.5 x 10, 12 ply on 2 pce 5 bolt rim | 445.00 | 302.60 |
|-----------|--|--------|--------|

Must choose 2 per unit

~ ~ Selection 4 ~ Extra Options ~ ~

| | | | |
|----------|---------------------|--------|--------|
| R000-200 | High Speed Sprocket | 198.00 | 134.64 |
| R900-800 | Shipping Kit | Net | 281.00 |
| | Assembly | Net | 400.00 |



Assembled unit



Shipping kit installed ready for truck



MASTER PRICE SHEET



Schulte Industries Ltd.

100 John Schulte Dr., Englefeld, SK. Canada, S0K 1N0

Tel: 306-287-3715 Fax: 306-287-3355 Toll Free: 1-800-404-6044

Web: www.Schulte.ca



Sourcewell - Road Right Of Way Maintenance Equipment

MACHINE PRICES AND SPECIFICATIONS

SRW-800 Rock Windrower

SPECIFICATIONS

- Variable Hydraulic Drum Angle 0 degrees to 18 degrees
- Drum Speed -- 102 rpm @ 540 input
- Horsepower Required --- 35hp to 100hp
- Tires -- 16.5 x 6.5 x 8 ply
- Maximum Ground Speed -- 5mph
- Transport Width -- 8.5'
- Recommended Ground Speed -- 2mph
- Transport Length -- 67"

~ ~ Selection 1 ~ Choose a Basic Unit ~ ~

| | | <i>Retail Price</i> | <i>Contract Price</i> |
|----|----------------------------------|---------------------|-----------------------|
| 1) | R300-000 SRW800 Standard 8' Unit | 17,740.00 | 12,063.20 |

~ ~ Selection 2 ~ Choose a Destination Code ~ ~

Please select the destination of the windrower for proper Decals and Manuals.

| | | | |
|----|-------------------------------------|-------|-------|
| 1) | R300-NA North America and Australia | 46.00 | 31.28 |
|----|-------------------------------------|-------|-------|

~ ~ Selection 3 ~ Extra Options ~ ~

| | | | |
|----|---|--------|--------|
| 1) | R000-200 High Speed Sprocket (for gravel reclamation) | 198.00 | 134.64 |
| | Assembly Charge | Net | 200.00 |





Schulte Industries Ltd.
 100 John Schulte Dr., Englefeld, SK, Canada, S0K 1N0
 Tel: 306-287-3715 Fax: 306-287-3355 Toll Free: 1-800-404-6044
 Web: www.Schulte.ca



Sourcewell - Road Right Of Way Maintenance Equipment
 MACHINE PRICES AND SPECIFICATIONS

SMR-800 Multi Skid-steer Windrower/Landscape Rake

SPECIFICATIONS

| | | | |
|----------------------|-------------------|------------|----------------------|
| Weight (approximate) | 1900 lbs (862 kg) | Drum width | 89" (2.26 m) |
| Transport width | 102" (2.59 m) | Tires | 23" forklift (58 cm) |

~ ~ **Selection 1 ~ Choose a Basic Unit** ~ ~

| | Retail Price | Contract Price |
|---|--------------|----------------|
| R500-100 Skid-steer Windrower Base Unit | 9,331.00 | 6,345.08 |

~ ~ **Selection 2 ~ Choose One Correct Harness (With Hydraulic Rotating Opt Only)** ~ ~

| | | |
|---|----------|----------|
| R500-315 Interface Harness, JCB/Takeuchi | 295.00 | 200.60 |
| R500-320 Interface Harness, Volvo | 295.00 | 200.60 |
| R500-325 Interface Harness, Kubota | 295.00 | 200.60 |
| R500-330 Interface Harness for CNH/Mustang/Gehl | 295.00 | 200.60 |
| R500-335 Interface Harness for Cat (14 pin) | 295.00 | 200.60 |
| R500-340 Interface Harness for JohnDeere | 295.00 | 200.60 |
| R500-345 Electric Harness With Switch Box | 758.00 | 515.44 |
| R500-350 Interface Harness for Bobcat | 2,307.00 | 1,568.76 |
| R500-355 CAT D-Series Adapter Harness | 388.00 | 263.84 |

~ ~ **Selection 3 ~ Choose Drum Configuration** ~ ~

| | | |
|---|----------|----------|
| R500-115 Standard Drum | 3,487.00 | 2,371.16 |
| <i>Choose Teeth Configuration</i> | | |
| R500-180 4 Inch Replaceable 450 BHN Steel Teeth | 1,624.00 | 1,104.32 |

~ ~ **Selection 4 ~ Choose Mount** ~ ~

| | | |
|-------------------------|----------|----------|
| R500-130 Standard Mount | 1,934.00 | 1,315.12 |
|-------------------------|----------|----------|

~ ~ **Selection 5 ~ Choose Wheel Option (must pick)** ~ ~

| | | |
|--------------------------|----------|----------|
| R500-610 Standard Wheels | 3,272.00 | 2,224.96 |
|--------------------------|----------|----------|

~ ~ **Selection 6 ~ Choose Rotation** ~ ~

| | | |
|------------------------------------|----------|----------|
| R500-205 Hydraulic Rotating option | 3,168.00 | 2,154.24 |
| R500-210 Manual Pivot Option | 624.00 | 424.32 |

~ ~ **Selection 7 ~ Choose Flow Option** ~ ~

| | | |
|---|----------|----------|
| R500-215 Drive Option 8.0 CU.IN. Motor | 1,442.00 | 980.56 |
| R500-220 Drive Option 15.0 CU.IN. Motor | 2,334.00 | 1,587.12 |
| R500-225 Drive Option 9.9 CU.IN. Motor | 2,202.00 | 1,497.36 |
| R500-230 Drive Option 19.0 CU.IN. Motor | 2,382.00 | 1,619.76 |
| R500-235 Drive Option 24.0 CU.IN. Motor | 2,510.00 | 1,706.80 |
| R500-240 Drive Option 12.5 CU.IN. Motor | 2,279.00 | 1,549.72 |
| Assembly | Net | 200.00 |

Use **this** flow chart to determine the proper Drive option

| GPM @2500psi | Motor size (cu. in.) | | | | |
|--------------|----------------------|-----|-----|-----|-----|
| | 8 | 9.9 | 15 | 19 | 24 |
| 18 | 213 | 168 | 112 | 90 | 69 |
| 20 | 237 | 189 | 125 | 101 | 77 |
| 22 | 263 | 208 | 138 | 112 | 85 |
| 25 | 299 | 238 | 157 | 126 | 98 |
| 27 | | 264 | 175 | 139 | 110 |
| 30 | | 285 | 188 | 152 | 119 |
| 35 | | | 221 | 178 | 136 |

Landscaping, levelling, seedbed prep – Target RPM from 175-260
 Large debris removal, rock windrowing – Target RPM from 110-140
 Sweeping – Target RPM 210



MASTER PRICE SHEET



Schulte Industries Ltd.

100 John Schulte Dr., Englefeld, SK. Canada, S0K 1N0
 Tel: 306-287-3715 Fax: 306-287-3355 Toll Free: 1-800-404-6044
 Web: www.Schulte.ca



Sourcewell - Road Right Of Way Maintenance Equipment MACHINE PRICES AND SPECIFICATIONS

SMR-600 Multi Skid-steer Windrower/Landscape Rake

SPECIFICATIONS

| | | | |
|----------------------|-------------------|------------|----------------------|
| Weight (approximate) | 1600 lbs (725 kg) | Drum width | 73" (1.85m) |
| Transport width | 88" (2.23m) | Tires | 23" forklift (58 cm) |

~ ~ Selection 1 ~ Choose a Basic Unit ~ ~

| | Retail Price | Contract Price |
|---|--------------|----------------|
| R700-100 Skid-steer Windrower Base Unit | 9,102.00 | 6,189.36 |

~ ~ Selection 2 ~ Choose One Correct Harness (With Hydraulic Rotating Opt only) ~ ~

| | | |
|---|----------|----------|
| R500-315 Interface Harness, JCB/Takeuchi | 295.00 | 200.60 |
| R500-320 Interface Harness, Volvo | 295.00 | 200.60 |
| R500-325 Interface Harness, Kubota | 295.00 | 200.60 |
| R500-330 Interface Harness for CNH | 295.00 | 200.60 |
| R500-335 Interface Harness for Cat (14 pin) | 295.00 | 200.60 |
| R500-340 Interface Harness for JohnDeere | 295.00 | 200.60 |
| R500-345 Electric Harness With Switch Box | 758.00 | 515.44 |
| R500-350 Interface Harness for Bobcat | 2,307.00 | 1,568.76 |
| R500-355 CAT D-Series Adapter Harness | 388.00 | 263.84 |

~ ~ Selection 3 ~ Choose Drum Configuration ~ ~

| | | |
|---|----------|----------|
| R700-115 Standard Drum with Replaceable Teeth | 2,562.00 | 1,742.16 |
| <i>Choose Teeth Configuration</i> | | |
| R700-125 4 inch 450 BHN Steel Replaceable Teeth | 1,346.00 | 915.28 |

~ ~ Selection 4 ~ Choose Mount ~ ~

| | | |
|-------------------------------|----------|----------|
| R500-130 Standard Rigid Mount | 1,934.00 | 1,315.12 |
|-------------------------------|----------|----------|

~ ~ Selection 5 ~ Choose Wheel Option (must pick) ~ ~

| | | |
|--------------------------|----------|----------|
| R500-610 Standard Wheels | 3,272.00 | 2,224.96 |
|--------------------------|----------|----------|

~ ~ Selection 6 ~ Choose Rotation ~ ~

| | | |
|------------------------------------|----------|----------|
| R700-215 Hydraulic Rotating option | 3,059.00 | 2,080.12 |
| R500-210 Manual Pivot Option | 624.00 | 424.32 |

~ ~ Selection 7 ~ Choose Flow Option ~ ~

| | | |
|---|----------|----------|
| R500-215 Drive Option 8.0 CU.IN. Motor | 1,442.00 | 980.56 |
| R500-220 Drive Option 15.0 CU.IN. Motor | 2,334.00 | 1,587.12 |
| R500-225 Drive Option 9.9 CU.IN. Motor | 2,202.00 | 1,497.36 |
| R500-230 Drive Option 19.0 CU.IN. Motor | 2,382.00 | 1,619.76 |
| R500-235 Drive Option 24.0 CU.IN. Motor | 2,510.00 | 1,706.80 |
| R500-240 Drive Option 12.5 CU.IN. Motor | 2,279.00 | 1,549.72 |
| | Assembly | Net |
| | | 200.00 |

Use this flow chart to determine the proper Drive option

| GPM @2500psi | Motor size (cu. in.) | | | | |
|--------------|----------------------|-----|-----|-----|-----|
| | 8 | 9.9 | 15 | 19 | 24 |
| 18 | 213 | 168 | 112 | 90 | 69 |
| 20 | 237 | 189 | 125 | 101 | 77 |
| 22 | 263 | 208 | 138 | 112 | 85 |
| 25 | 299 | 238 | 157 | 126 | 98 |
| 27 | | 264 | 175 | 139 | 110 |
| 30 | | 285 | 188 | 152 | 119 |
| 35 | | | 221 | 178 | 136 |

Landscaping, levelling, seedbed prep – Target RPM from 175-260
 Large debris removal, rock windrowing – Target RPM from 110-140



MASTER PRICE SHEET



Schulte Industries Ltd.

100 John Schulte Dr., Englefeld, SK. Canada, S0K 1N0

Tel: 306-287-3715 Fax: 306-287-3355 Toll Free: 1-800-404-6044

Web: www.Schulte.ca



Sourcewell - Road Right Of Way Maintenance Equipment

MACHINE PRICES AND SPECIFICATIONS

RS320 'Jumbo' Rock Picker

PICKER FEATURES

- Hydraulic cylinders & hoses
- Grated buckets
- Extended hitch poles
- Pivoting hitch
- Safety chain

TRACTOR HYDRAULIC REQUIREMENTS

Rock pickers, hydraulically driven, **require closed center** dual remote outlets with a minimum of 12 gallons per minute flow at 1750 psi.

~ ~ **Selection 1 ~ Choose a Basic Unit** ~ ~

| | | <i>Retail Price</i> | <i>Contract Price</i> |
|------------------|--|---------------------|-----------------------|
| 1) 90-100 | RS320 'Jumbo' Rock Picker, conveyer type, hydraulic drive, semi hi-lift, 4 batt, 3.2 cubic yard grated bucket c/w pivoting hitch, 16.5x16.1x10 Ply Tires | 51,735.00 | 35,179.80 |

~ ~ **Selection 2 ~ Extra Options** ~ ~

| | | | |
|--------------------|--|--------|--------|
| 1) S000-075 | Safety Light Kit | 879.00 | 597.72 |
| 2) 90-250 | Hydraulic Swing Hitch (For RS320 Only) | 672.00 | 456.96 |
| | Setup For Loading | Net | 250.00 |
| | Setup For Towing | Net | 300.00 |

IMPORTANT: Safety Chain Kit & Safety Light Kit must be used at all time when moving equipment on any type of road.

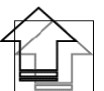

MASTER PRICE SHEET



Schulte Industries Ltd.

100 John Schulte Dr., Englefeld, SK. Canada, S0K 1N0

Tel: 306-287-3715 Fax: 306-287-3355 Toll Free: 1-800-404-6044

Web: www.Schulte.ca



Sourcewell - Road Right Of Way Maintenance Equipment

MACHINE PRICES AND SPECIFICATIONS

2500 Giant Rock Picker

PICKER FEATURES

- Hydraulic cylinders & hoses
- Grated buckets
- Extended hitch poles
- Pivoting hitch
- Safety chain

TRACTOR HYDRAULIC REQUIREMENTS

Rock pickers, hydraulically driven, **require closed center** dual remote outlets with a minimum of 12 gallons per minute flow at 1750 psi.

~ ~ **Selection 1 ~ Choose a Basic Unit** ~ ~

| | | | <i>Retail Price</i> | <i>Contract Price</i> |
|----|----------|---|---------------------|-----------------------|
| 1) | R100-001 | 2500 Giant Big Bucket Rock Picker, reel type, pivoting hitch, rock deflector, hydraulic drive, semi hi-lift, 16.5x16.1x10 Ply Tires | 30,695.00 | 20,872.60 |
| | | <i>Choose One:</i> | | |
| | a) | R100-190 Heavy Duty Grate and Reel Assembly, Narrow Space <i>c/w Replaceable Teeth, 1-1/2" Spacing</i> | 18,149.00 | 12,341.32 |
| | b) | R100-215 Heavy Duty Grate and Reel Assembly, Wide Space <i>c/w Replaceable Teeth, 3-9/32" Spacing</i> | 15,561.00 | 10,581.48 |
| | | <i>Choose One Required Option:</i> | | |
| | a) | R400-140 Longer Bent Hitch Pole | 2,426.00 | 1,649.68 |
| | | <i>Pick one of the Following:</i> | | |
| | a) | R100-265 Standard Hydraulics | 326.00 | 221.68 |
| | b) | R100-270 Flow Control Kit | 717.00 | 487.56 |

~ ~ **Selection 2 ~ Extra Options** ~ ~

| | | | | |
|----|----------|-------------------------------------|--------|--------|
| 1) | S000-039 | Safety Light Kit | 818.00 | 556.24 |
| 2) | R400-255 | Hydraulic Swing Hitch (2500 Giant) | 503.00 | 342.04 |
| | | Setup For Loading | Net | 250.00 |
| | | Setup For Towing | Net | 300.00 |

IMPORTANT: Safety Chain Kit & Safety Light Kit must be used at all time when moving equipment on any type of road.



MASTER PRICE SHEET



Schulte Industries Ltd.

100 John Schulte Dr., Englefeld, SK. Canada, S0K 1N0

Tel: 306-287-3715 Fax: 306-287-3355 Toll Free: 1-800-404-6044

Web: www.Schulte.ca



Sourcewell - Road Right Of Way Maintenance Equipment

MACHINE PRICES AND SPECIFICATIONS

3500 Giant Rock Picker

PICKER FEATURES

- Hydraulic cylinders & hoses
- Grated buckets
- Extended hitch poles
- Pivoting hitch
- Safety chain

TRACTOR HYDRAULIC REQUIREMENTS

Rock pickers, hydraulically driven, **require closed center** dual remote outlets with a minimum of 12 gallons per minute flow at 1750 psi.

~ ~ Selection 1 ~ Choose a Basic Unit ~ ~

| | | | <i>Retail Price</i> | <i>Contract Price</i> |
|----|----------|---|---------------------|-----------------------|
| 1) | R350-100 | 3500 Giant Base Unit | 26,820.00 | 18,237.60 |
| | | <i>Choose one:</i> | | |
| | a) | R350-235 Contractor Heavy Duty Grate and Reel Assembly, Narrow Space c/w Replaceable Teeth, 1-1/2" Spacing | 23,634.00 | 16,071.12 |
| | b) | R350-225 Contractor Heavy Duty Grate and Reel Assembly, Wide Space c/w Replaceable Teeth, 3-9/32" Spacing | 19,461.00 | 13,233.48 |

~ ~ Selection 2 ~ Choose a Hitch Pole ~ ~

| | | | | |
|----|----------|---|----------|----------|
| 2) | R400-140 | Bent Hitch Pole | 2,426.00 | 1,649.68 |
| | | <i>Pick one of the Following:</i> | | |
| | a) | R100-265 Standard Hydraulics | 326.00 | 221.68 |
| | b) | R100-270 Hydraulics w/ Flow Control Kit | 717.00 | 487.56 |

MASTER PRICE SHEET



Schulte Industries Ltd.

100 John Schulte Dr., Englefeld, SK. Canada, S0K 1N0

Tel: 306-287-3715 Fax: 306-287-3355 Toll Free: 1-800-404-6044

Web: www.Schulte.ca



Sourcewell - Road Right Of Way Maintenance Equipment

MACHINE PRICES AND SPECIFICATIONS

3500 Giant Rock Picker

~ ~ **Selection 3 ~ Wheel Options** ~ ~

| | | | | |
|----|----------|--|----------|----------|
| 1) | R350-300 | Standard Wheel Option <i>(16.5 x 16.1 x 10 Ply)</i> | 4,260.00 | 2,896.80 |
| 2) | R350-350 | Larger Wheel Option <i>(560/45 x 22.5, 152 D Load Index)</i> | 8,007.00 | 5,444.76 |

~ ~ **Selection 4 ~ Rock Deflector Options** ~ ~

| | | | | |
|----|----------|--|--------|--------|
| 1) | R350-400 | Standard Side Rock Deflector <i>Order with R350-300 (Standard Wheel Option)</i> | 409.00 | 278.12 |
| 2) | R350-450 | Large Side Rock Deflector <i>Order with R350-350 (Larger Wheel Option)</i> | 456.00 | 310.08 |

~ ~ **Selection 5 ~ Extra Options** ~ ~

| | | | | |
|----|----------|-----------------------|--------|--------|
| 1) | S000-175 | Safety Light Kit | 889.00 | 604.52 |
| 2) | R400-255 | Hydraulic Swing Hitch | 503.00 | 342.04 |

| | | | |
|--|--------------------------|------------|---------------|
| | Setup For Loading | Net | 250.00 |
| | Setup For Towing | Net | 300.00 |

IMPORTANT: Safety Chain Kit & Safety Light Kit must be used at all time when moving equipment on any type of road.

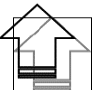

MASTER PRICE SHEET



Schulte Industries Ltd.

100 John Schulte Dr., Englefeld, SK. Canada, S0K 1N0

Tel: 306-287-3715 Fax: 306-287-3355 Toll Free: 1-800-404-6044

Web: www.Schulte.ca



Sourcewell - Road Right Of Way Maintenance Equipment

MACHINE PRICES AND SPECIFICATIONS

5000 Titan II Rock Picker

PICKER FEATURES

- Dumping height - 79" (2007 mm)
- Hopper capacity - 5 cu. yds. (3.82 m³)
- 450 BHN Steel teeth and T-iron tops for extra-long life
- Hydraulic Pivoting hitch
- Picks rocks - 2" - 27" (5cm - 69cm)
- Required horsepower -125 HP (93 kW)
- Required tractor hydraulic capacity at 4 remote outlets
12 GPM@2200PSI, 4 remote outlets
- Case Drain Required
- Recommended Reel Speed 36 rpm

~ ~ Selection 1 ~ Choose a Basic Unit ~ ~

| | | <i>Retail Price</i> | <i>Contract Price</i> |
|----------|--|---------------------|-----------------------|
| R801-100 | 5000 TITAN II Rock Picker 5 cu.yd. bucket, 6.5 ft Dump Height, Hydraulic Swing Hitch | 60,687.00 | 41,267.16 |
| R800-200 | Optional Rock Deflector | 505.00 | 343.40 |

~ ~ Selection 2 ~ Reel and Grates ~ ~

| | | | |
|----------|--|-----------|-----------|
| R801-200 | Grate and Reel c/w Narrow 1 1/2" spacing, 450 BHN Steel Teeth and T-iron | 32,334.00 | 21,987.12 |
| R801-225 | Grate and Reel c/w Wide 3 9/32" spacing, 450 BHN Steel Teeth and T-iron | 28,555.00 | 19,417.40 |

~ ~ Selection 3 ~ Reel and Grates ~ ~

| | | | |
|----------|----------------------|--------|----------|
| R800-250 | Flow Control Kit | 384.00 | 261.12 |
| R800-800 | Containerized/Racked | Net | 3,200.00 |
| R800-810 | Set up for loading | Net | 400.00 |
| | Setup For Towing | Net | 600.00 |

PREDELIVERY SERVICE IS REQUIRED BY DEALER OR END USER

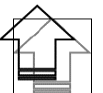

MASTER PRICE SHEET



Schulte Industries Ltd.

100 John Schulte Dr., Englefeld, SK. Canada, S0K 1N0

Tel: 306-287-3715 Fax: 306-287-3355 Toll Free: 1-800-404-6044

Web: www.Schulte.ca



Sourcewell - Road Right Of Way Maintenance Equipment

MACHINE PRICES AND SPECIFICATIONS

SPARTAN RWP-1935

PICKER / WINDROWER COMBO

PICKER FEATURES

- Dumping height of over 8-1/2' (2.6m)
- Hopper capacity - 3.5 cu. yds. (2.68 m³)
- Hard surfaced teeth & batt reels for extra-long life
- Adjustable working widths of 16' - 19' (4.8m - 5.8m)
- Picks rocks - 2" - 27" (5cm - 69cm)
- Adjustable working depths down to 4.25" (11 cm)
- Separate hydraulic adjustment of windrower & reel speeds
- Minimum horsepower -125 HP (93 kW)
- Required tractor hydraulic capacity - 16 GPM with two remotes
- Recommended reel speed - 40 rpm
- Case drain required
- PTO required to run hydraulic pump that is available in 3 standard shaft size

~ ~ Selection 1 ~ Choose a Basic Unit ~ ~

| | | Retail Price | Contract Price |
|----------|---|---------------------|-----------------------|
| R190-100 | RWP-1935 Rock Picker / Rock Windrower Combo Base Unit | 152,999.00 | 104,039.32 |

~ ~ Selection 2 ~ Hydraulic Pump Options ~ ~

| | | | |
|----------|---|----------|----------|
| R190-300 | 540 RPM Hydraulic Pump, 1-3/8" 6 Spline | 5,241.00 | 3,563.88 |
| R190-310 | 1000 RPM Hydraulic Pump, 1-3/8" 21 Spline | 5,600.00 | 3,808.00 |
| R190-320 | 1000 RPM Hydraulic Pump, 1-3/4" 20 Spline | 6,914.00 | 4,701.52 |

~ ~ Selection 3 ~ Options ~ ~

| | | | |
|----------|---|--------|--------|
| R190-400 | Reel Guard Option <i>(Adds 3" to the dump height)</i> | 484.00 | 329.12 |
|----------|---|--------|--------|

| | | |
|---------------------------|------------|-----------------|
| Setup For Shipping | Net | 2,600.00 |
|---------------------------|------------|-----------------|

PREDELIVERY SERVICE IS REQUIRED BY DEALER OR END USER



Canadian Price List Index



Schulte Industries Ltd.

100 John Schulte Dr., Englefeld, SK. Canada, S0K 1N0
Tel: 306-287-3715 Fax: 306-287-3355 Toll Free: 1-800-404-6044
Web: www.Schulte.ca

Sourcewell - Road Right Of Way Maintenance Equipment



Click on this symbol to
return to this index page



Rotary Cutters

FX742 - 42 Ft Rotary Cutter

FX530 - 30 Ft Rotary Cutter

5026 - 26 Ft Rotary Cutter

5024 - 24 Ft Rotary Cutter

FX520 - 20 Ft Rotary Cutter

FX320 - 20 Ft Rotary Cutter

FX318 - 18 Ft Rotary Cutter

FX212 - 12 Ft Rotary Cutter

TPX-318 3PT - 18 Ft Rotary Cutter

XH1500 Series 5 - 15 Ft Rotary Cutter

SFT Pro XH1500 Series 5 - 15 Ft Rotary Cutter

Cutter Command System - XH1500 Series 5 / XH1000 Series 5

XH1000 Series 5 - 10 Ft Rotary Cutter

FX1800 - 15 Ft Rotary Cutter

FX1800C - 15 Ft Rotary Cutter (DOT Configuration Options)

FX1200 - 12 Ft Rotary Cutter

FX1200C - 12 Ft Rotary Cutter (DOT Configuration Options)

GX150 - 15 Ft Rotary Cutter

GX130 - 13 Ft Rotary Cutter

FLX1510 - Flex Arm For 10' & 15' Schulte Rotary Cutters

FX209 - 9 Ft Rotary Cutter

FX107 - 7 Ft Rotary Cutter

Eliminator Spray Kit For XH1500 Rotary Cutters

MASTER PRICE SHEET



Schulte Industries Ltd.

100 John Schulte Dr., Englefeld, SK. Canada, S0K 1N0

Tel: 306-287-3715 Fax: 306-287-3355 Toll Free: 1-800-404-6044

Web: www.Schulte.ca

Sourcewell - Road Right Of Way Maintenance Equipment

MACHINE PRICES AND SPECIFICATIONS

FX-742 Rotary Cutter

~ The World's Largest Rotary Cutter ~



CUTTER FEATURES

- 42ft Cutting Width (12.8 m)
- 2" - 16" Cutting Height (51-406 mm)
- 118" Transport Width (3m)
- 10 ga Domed Deck (3.4 mm)
- Replaceable 2 Piece Skid Shoes
- 2" Cutting Capacity (51 mm)
- 250hp Minimum Tractor Size
- Floating Hitch
- 10 Gearbox Layout with
- 7 Slip Clutches (7 down clutches)
- 18,000 lbs Total Weight (8,165 kgs)
- Hydraulic Phasing & Mechanical Hybrid Lift System with Hydraulic Depth Control
- Adjustable Wheel Standards
- 1 Year Full Warranty & 3 Years Limited Gearbox Warranty
- Easy to Use Safety Lock Up

~ ~ Selection 1 ~ Choose a Basic Unit ~ ~

| | | Retail Price | Contract Price |
|----------|-----------------------------|--------------|----------------|
| C742-100 | FX742 Rotary Cutter | 177,964.00 | 121,015.52 |
| S000-097 | Safety Light Kit (Required) | 824.00 | 560.32 |

~ ~ Selection 2 ~ Choose Hitch ~ ~

| | | | |
|----------|---|----------|----------|
| C742-855 | Trailing Hitch, CV Style w/ Manual Hitch Jack | 5,310.00 | 3,610.80 |
| C742-335 | Trailing Hitch, CV Style w/ Hydraulic Jack | 6,463.00 | 4,394.84 |

~ ~ Selection 3 ~ Choose Axle and Tire Configuration ~ ~

| | | | |
|----------|---|-----------|-----------|
| C742-630 | Through Axle Kit - Choose 10 Tires | 9,497.00 | 6,457.96 |
| C742-635 | Walking Axle Kit - Choose 14 Tires | 15,769.00 | 10,722.92 |

~ ~ Selection 4 ~ Choose Tire Option ~ ~

| | | Retail Price/Tire | Contract Price/Tire |
|-----------|--|-------------------|---------------------|
| 210-560WG | Tire Assembly Stubble Proof (Choose Quantity of Tires Needed - 10 or 14) | 902.00 | 613.36 |

~ ~ Selection 5 ~ Choose a Blade Configuration ~ ~

| | | | |
|----------|--|-----------|-----------|
| C742-250 | Pan Kit with Updraft Blades | 11,370.00 | 7,731.60 |
| C742-265 | Fixed Knife Kit with Flat Double Sided Blades & Shrouds (For Cotton) | 18,275.00 | 12,427.00 |
| C742-270 | Fixed Knife Kit with Updraft Blades & Shrouds | 18,275.00 | 12,427.00 |

MASTER PRICE SHEET



Schulte Industries Ltd.

100 John Schulte Dr., Englefeld, SK. Canada, S0K 1N0

Tel: 306-287-3715 Fax: 306-287-3355 Toll Free: 1-800-404-6044

Web: www.Schulte.ca

Sourcewell - Road Right Of Way Maintenance Equipment

MACHINE PRICES AND SPECIFICATIONS

FX-742 Rotary Cutter

~ The World's Largest Rotary Cutter ~



~ ~ Selection 6 ~ Choose a Safety Guard & Accessories ~ ~

| | | | |
|----------|--|----------|----------|
| C742-500 | Single Chains Front & Rear | 6,145.00 | 4,178.60 |
| C742-525 | Double Chains Front and Rear | 6,910.00 | 4,698.80 |
| C742-550 | Front & Rear Rubber Belting | 3,576.00 | 2,431.68 |
| C742-580 | Single Chains Front & Rear with Front Rubber Belting | 7,216.00 | 4,906.88 |

~ ~ Selection 7 ~ Choose Wheel Extension Kit ~ ~

| | | | |
|----------|--|----------|----------|
| C742-350 | Row Crop Wheel Extensions <i>(Will accommodate 30", 32", 36", 38", 40" + 1m rows)</i> <i>(Transport width of 146" or 3.7m)</i> | 1,839.00 | 1,250.52 |
|----------|--|----------|----------|

NOTE: All Tires Are 11L x 15 x 12 Ply Rated

~ ~ Selection 8 ~ Choose a Destination Code ~ ~

| | | | |
|---------|--------------------------------|--------|--------|
| C742-NA | North American Destination Kit | 368.00 | 250.24 |
|---------|--------------------------------|--------|--------|

~ ~ Selection 9 ~ Options ~ ~

| | | | |
|----------|--|-----------|-----------|
| C742-780 | Fan Debris Kit, Factory Installed | 17,576.00 | 11,951.68 |
| C742-790 | Fan Debris Kit, Crated | 17,060.00 | 11,600.80 |

| | | |
|---|------------|-----------------|
| Assembly charge on pan units | Net | 1,300.00 |
| Assembly charge on fixed blade units | Net | 1,400.00 |



MASTER PRICE SHEET



Schulte Industries Ltd.

100 John Schulte Dr., Englefeld, SK. Canada, S0K 1N0

Tel: 306-287-3715 Fax: 306-287-3355 Toll Free: 1-800-404-6044

Web: www.Schulte.ca

Sourcewell - Road Right Of Way Maintenance Equipment

MACHINE PRICES AND SPECIFICATIONS

FX-530 Rotary Cutter



CUTTER FEATURES

- 30' of mowing and shredding excellence
- Accommodates 30", 32", 36", 38" row spacings
 - Spun formed pans available on pan unit
- Excellent shredding and distribution capabilities on Fixed Knife units allows for
- Unique drive layout allows for clutch on every down box
- Phasing system for parallel lift cut
- Non-adjustable clutches provide low maintenance
- Available **Cyclone Deck Debris Fan Kit**
- 350 hp, 60° degree splitter gearbox
- Unique driveline layout
- Floating hitch with rubber grommet rear

~ ~ Selection 1 ~ Choose a Basic Unit, Drive Package ~ ~

| | | Retail Price | Contract Price |
|----|--|---------------------|-----------------------|
| 1) | C530-100 Schulte FX-530, Basic Unit (Required) | 94,786.00 | 64,454.48 |
| 2) | S000-097 Safety Light Kit (Required) | 824.00 | 560.32 |

~ ~ Selection 2 ~ Choose a Hitch Option ~ ~

| | | | | |
|--|--|--|-----------------|-----------------|
| C530-810 | Trailing Hitch, CV Style | OR | 3,711.00 | 2,523.48 |
| C530-845 | Trailing Hitch, CV Style w/ Hydraulic Jack | | 6,052.00 | 4,115.36 |
| Choose a Shaft | | | | |
| a) | 340-885WG | 1 3/4 inch Tractor Shaft | 3,067.00 | 2,085.56 |
| b) | 340-875WG | 1 3/8 inch Tractor Shaft | 2,938.00 | 1,997.84 |
| C530-800 | Trailing Equal Angle Hitch Sub Assembly | | 3,947.00 | 2,683.96 |
| Must Choose a Hitch Block | | | | |
| a) | C502-821 | Category 3, fits up to a 1-1/2" pin and a drawbar 2-1/4" x 3-1 | 464.00 | 315.52 |
| b) | C502-822 | Category 4, fits up to a 2" pin and a drawbar 2-1/2" x 5-1/8" | 463.00 | 314.84 |
| Choose a Tractor Shaft: | | | | |
| IMPORTANT: PTO Adaptor must not be used in any application. | | | | |
| a) | 340-5505WG | Equal Angle Shaft, 1 3/8" x 21 Spline | 1,518.00 | 1,032.24 |
| b) | 340-5509WG | Equal Angle Shaft, 1 3/4" x 20 Spline | 1,600.00 | 1,088.00 |

MASTER PRICE SHEET



Schulte Industries Ltd.

100 John Schulte Dr., Englefeld, SK. Canada, S0K 1N0

Tel: 306-287-3715 Fax: 306-287-3355 Toll Free: 1-800-404-6044

Web: www.Schulte.ca

Sourcewell - Road Right Of Way Maintenance Equipment

MACHINE PRICES AND SPECIFICATIONS

FX-530 Rotary Cutter



~ ~ Selection 3 ~ Choose an Extension Kit ~ ~

| | | | |
|----------|---------------------|----------|----------|
| C530-350 | Row Crop Extensions | 1,541.00 | 1,047.88 |
|----------|---------------------|----------|----------|

~ ~ Selection 4 ~ Choose an Axle Kit ~ ~

| | | | |
|----------|---|-----------|----------|
| C530-625 | Non Walking Wheel Standards <i>(Choose 8 Tires)</i> | 7,209.00 | 4,902.12 |
| C530-635 | Walking Axles <i>(choose 10 Tires)</i> | 10,463.00 | 7,114.84 |
| C530-670 | Standard Axle Add-on <i>(Choose 2 tires)</i> | 2,146.00 | 1,459.28 |

~ ~ Selection 5 ~ Choose Tire Kit ~ ~

| | | Retail Price/Tire | Contract Price/Tire |
|-----------|---|-------------------|---------------------|
| 210-511WG | Light Truck Tires <i>(Choose quantity of tires needed 8, 10 or 2)</i> | 470.00 | 319.60 |
| 210-560WG | Tire Assembly Stubble Proof <i>(Choose quantity of tires needed 8, 10 or 2)</i> | 902.00 | 613.36 |

~ ~ Selection 6 ~ Choose a Pan or Fixed Knife Kit ~ ~

| | | | |
|----------|--|----------|----------|
| C530-250 | Pans and Updraft Blades | 7,498.00 | 5,098.64 |
| C530-270 | Fixed Knife Kit c/w Shrouds and Updraft Blades | 8,795.00 | 5,980.60 |
| C530-280 | Fixed Knife kit c/w Shrouds and Non Updraft Blades (For Cotton) | 8,795.00 | 5,980.60 |

~ ~ Selection 7 ~ Choose a Shielding Kit or Combination ~ ~

| | | | |
|----------|---------------------------|----------|----------|
| C530-500 | Front Single Chains | 1,789.00 | 1,216.52 |
| C530-510 | Rear Single Chains | 2,117.00 | 1,439.56 |
| C530-550 | Front Double Chains | 2,191.00 | 1,489.88 |
| C530-560 | Rear Double Chains | 2,613.00 | 1,776.84 |
| C530-570 | Half-length front belting | 658.00 | 447.44 |
| C530-575 | Half-length rear belting | 658.00 | 447.44 |
| C530-580 | Front Belting | 868.00 | 590.24 |
| C530-590 | Rear Belting | 868.00 | 590.24 |

MASTER PRICE SHEET



Schulte Industries Ltd.

100 John Schulte Dr., Englefeld, SK. Canada, S0K 1N0

Tel: 306-287-3715 Fax: 306-287-3355 Toll Free: 1-800-404-6044

Web: www.Schulte.ca

Sourcewell - Road Right Of Way Maintenance Equipment

MACHINE PRICES AND SPECIFICATIONS

FX-530 Rotary Cutter



~ ~ Selection 8 ~ Choose Destination Kit ~ ~

| | | | |
|---------|--------------------------|--------|--------|
| C530-NA | North American Decal Kit | 226.00 | 153.68 |
|---------|--------------------------|--------|--------|

~ ~ Selection 9 ~ Choose Options ~ ~

| | | | |
|----------|---|-----------|-----------|
| C530-330 | Hydraulic Actuated Outer Wings | 2,244.00 | 1,525.92 |
| C530-780 | Cyclone Fan Debris Kit, Factory Installed | 17,291.00 | 11,757.88 |
| C530-790 | Cyclone Fan Debris Kit, Crated | 16,944.00 | 11,521.92 |
| | Assembly Charge on Pan Units | Net | 1,000.00 |
| | Assembly Charge on Fixed Blades | Net | 1,100.00 |



MASTER PRICE SHEET



Schulte Industries Ltd.

100 John Schulte Dr., Englefeld, SK. Canada, S0K 1N0

Tel: 306-287-3715 Fax: 306-287-3355 Toll Free: 1-800-404-6044

Web: www.Schulte.ca

Sourcewell - Road Right Of Way Maintenance Equipment

MACHINE PRICES AND SPECIFICATIONS

5026 Rotary Cutter



CUTTER FEATURES

- 10GA deck
- Phasing cylinders (3) c/w hoses
- Wing lift cylinders (2) c/w hoses
- Suspension for center and wings
- Spring steel bushings at major pivot points
- 1000 RPM
- Deck protection rings
- S000-010 safety chain kit 1/4" grade 70 with 10,000 lbs capacity
- Two piece replaceable skid shoes
- Operator's manual in holder

~ ~ Selection 1 ~ Choose a Basic Unit ~ ~

| | | <i>Retail Price</i> | <i>Contract Price</i> |
|----|---|---------------------|-----------------------|
| 1) | C502-100 Basic 26' Unit, 1000 RPM | 78,108.00 | 53,113.44 |
| 2) | S000-135 Safety Light Kit (Required) | 911.00 | 619.48 |

~ ~ Selection 2 ~ Choose a Hitch Type and Accessories ~ ~

| | | | |
|----|--|-----------------|-----------------|
| 1) | C502-810 Trailing hitch, CV Style | 1,801.00 | 1,224.68 |
| | Choose a Clevis: | | |
| | a) C502-113WG Solid Tongue | 321.00 | 218.28 |
| | b) C502-107WG Open Clevis | 233.00 | 158.44 |
| | c) C000-300WG Precision hitch | 695.00 | 472.60 |
| | d) C502-815WG Clevis with 2 3/16" Opening | 366.00 | 248.88 |
| | e) C502-816WG Solid Tongue with 2-3/16 hole for a 2" pin | 845.00 | 574.60 |
| | Choose a Tractor Shaft: | | |
| | a) 340-8082WG CV Shaft, 1 3/4" x 20 Spline | 3,050.00 | 2,074.00 |
| | b) 340-8092WG CV Shaft, 1 3/8" x 21 Spline | 3,050.00 | 2,074.00 |
| 2) | C502-820 Trailing Equal Angle Hitch Sub Assembly | 3,116.00 | 2,118.88 |
| | Must Choose a Hitch Block | | |
| | a) C502-821 Category 3, fits up to a 1-1/2" pin and a drawbar 2-1/4" x 3-1/2" | 464.00 | 315.52 |
| | b) C502-822 Category 4, fits up to a 2" pin and a drawbar 2-1/2" x 5-1/8" | 463.00 | 314.84 |
| | Choose a Tractor Shaft: | | |
| | a) 340-5505WG Equal Angle Shaft, 1 3/8" x 21 Spline | 1,518.00 | 1,032.24 |
| | b) 340-5509WG Equal Angle Shaft, 1 3/4" x 20 Spline | 1,600.00 | 1,088.00 |

IMPORTANT: PTO Adaptor must not be used in any application.

MASTER PRICE SHEET



Schulte Industries Ltd.

100 John Schulte Dr., Englefeld, SK. Canada, S0K 1N0

Tel: 306-287-3715 Fax: 306-287-3355 Toll Free: 1-800-404-6044

Web: www.Schulte.ca

Sourcewell - Road Right Of Way Maintenance Equipment

MACHINE PRICES AND SPECIFICATIONS

5026 Rotary Cutter



~ ~ Selection 3 ~ Choose a Blade Configuration ~ ~

| | | | |
|-----------------|--|------------------|-----------------|
| C502-250 | Two Blade Pan Kit | 7,724.00 | 5,252.32 |
| C502-251 | Two Blade Pan Kit with Shredder Blades | 8,651.00 | 5,882.68 |
| C502-270 | Fixed Knife Shredder Kit with Updraft Blades | 11,853.00 | 8,060.04 |
| C502-280 | Fixed Knife Shredder Kit with Flat Blades <i>(recommended for cotton)</i> | 11,853.00 | 8,060.04 |

~ ~ Selection 4 ~ Choose a Safety Guard & Accessories ~ ~

| | | | |
|-----------------|--|-----------------|-----------------|
| C502-420 | Single Safety Chains Front & Rear c/w Front Rubber Belting (recommended for cotton & corn) | 4,085.00 | 2,777.80 |
| C502-430 | Single Safety Chains Front Only c/w Front & Rear Rubber Belting (recommended for dry grass staw, wheat straw & barley straw) | 3,175.00 | 2,159.00 |
| C502-500 | Single Safety Chains Front & Rear | 3,588.00 | 2,439.84 |
| C502-440 | Single Safety Chains Front & Rear c/w frt & rear belting | 5,176.00 | 3,519.68 |
| C502-550 | Double Safety Chains Front & Rear | 4,430.00 | 3,012.40 |

MASTER PRICE SHEET



Schulte Industries Ltd.

100 John Schulte Dr., Englefeld, SK. Canada, S0K 1N0

Tel: 306-287-3715 Fax: 306-287-3355 Toll Free: 1-800-404-6044

Web: www.Schulte.ca

Sourcewell - Road Right Of Way Maintenance Equipment

MACHINE PRICES AND SPECIFICATIONS

5026 Rotary Cutter



~ ~ Selection 5 ~ Choose Axle Option ~ ~

| | | | |
|-----------------|--|-----------------|-----------------|
| C502-643 | Standard Axle Kit <i>(Choose 6 Tires cannot use stubble proof tires)</i> | 5,925.00 | 4,029.00 |
| C502-649 | Standard Axle Kit <i>(Choose 8 Tires cannot use stubble proof tires)</i> | 8,337.00 | 5,669.16 |
| C502-644 | Walking Axle Kit <i>(Choose 8 Tires cannot use stubble proof tires)</i> | 7,510.00 | 5,106.80 |
| C502-648 | 618 Walking Axle Kit <i>(Choose 8 tires Stubble proof only)</i> | 8,180.00 | 5,562.40 |

~ ~ Selection 6 ~ Choose Tire Kit ~ ~

| | | Retail Price/Tire | Contract Price/Tire |
|-------------------|---|-------------------|---------------------|
| 210-182WG | Aircraft Tire <i>(Choose quantity of tires needed 6 or 8)</i> | 622.00 | 422.96 |
| 210-182FWG | Foam Filled Aircraft Tire <i>(Choose quantity of tires needed 6 or 8)</i> | 1,102.00 | 749.36 |
| 210-560WG | Tire Assembly Stubble Proof <i>(Choose 8 Tires)</i> | 902.00 | 613.36 |
| 210-505WG | Light Truck Tire <i>(Choose quantity of tires needed 6 or 8)</i> | 424.00 | 288.32 |

~ ~ Selection 7 ~ Schulte Fan Kit ~ ~

| | | | |
|-----------------|--|------------------|------------------|
| C502-780 | Cyclone Fan Debris Kit, Factory Installed | 17,232.00 | 11,717.76 |
| C502-790 | Cyclone Fan Debris Kit, Crated | 16,988.00 | 11,551.84 |

~ ~ Selection 8 ~ Choose a Destination Code ~ ~

| | | | |
|----------------|---|---------------|--------------|
| C502-NA | North America and Australia Destination Kit | 147.00 | 99.96 |
|----------------|---|---------------|--------------|

~ ~ Selection 9 ~ Extra Options ~ ~

| | | | |
|-----------------|--------------------------------------|---------------|---------------|
| C502-625 | Row crop Extension Kit | 598.00 | 406.64 |
| | Assembly charge on pan units | Net | 650.00 |
| | Assembly charge on fixed blade units | Net | 750.00 |



MASTER PRICE SHEET



Schulte Industries Ltd.

100 John Schulte Dr., Englefeld, SK. Canada, S0K 1N0

Tel: 306-287-3715 Fax: 306-287-3355 Toll Free: 1-800-404-6044

Web: www.Schulte.ca

Sourcewell - Road Right Of Way Maintenance Equipment

MACHINE PRICES AND SPECIFICATIONS

5024 Rotary Cutter



CUTTER FEATURES

- 10GA deck
- Phasing cylinders (3) c/w hoses
- Wing lift cylinders (2) c/w hoses
- Suspension for center and wings
- Spring steel bushings at major pivot points
- 1000 RPM
- Deck protection rings
- S000-010 safety chain kit 1/4" grade 70 with 10,000 lbs capacity
- Two piece replaceable skid shoes
- Operator's manual in holder

~ ~ Selection 1 ~ Choose a Basic Unit ~ ~

| | | <i>Retail Price</i> | <i>Contract Price</i> |
|----|---|---------------------|-----------------------|
| 1) | C524-100 Basic 24' Unit, 1000 RPM | 75,423.00 | 51,287.64 |
| 2) | S000-135 Safety Light Kit (Required) | 911.00 | 619.48 |

~ ~ Selection 2 ~ Choose a Hitch Type and Accessories ~ ~

| | | | |
|----|---|----------|----------|
| 1) | C502-810 Trailing hitch, CV Style | 1,801.00 | 1,224.68 |
| | Choose a Clevis: | | |
| a) | C502-113WG Solid Tongue | 321.00 | 218.28 |
| b) | C502-107WG Open Clevis | 233.00 | 158.44 |
| c) | C000-300WG Precision hitch | 695.00 | 472.60 |
| d) | C000-360WG Adjustable Clevis | 382.00 | 259.76 |
| e) | C502-815WG Clevis with 2 3/16" Opening | 366.00 | 248.88 |
| f) | C502-816WG Solid Tongue with 2-3/16 hole for a 2" pin | 845.00 | 574.60 |
| | Choose a Tractor Shaft: | | |
| a) | 340-8082WG CV Shaft, 1 3/4" x 20 Spline | 3,050.00 | 2,074.00 |
| b) | 340-8092WG CV Shaft, 1 3/8" x 21 Spline | 3,050.00 | 2,074.00 |
| 2) | C502-820 Trailing Equal Angle Hitch Sub Assembly | 3,116.00 | 2,118.88 |
| | Must Choose a Hitch Block | | |
| a) | C502-821 Category 3, fits up to a 1-1/2" pin and a drawbar 2-1/4" x 3-1/2" | 464.00 | 315.52 |
| b) | C502-822 Category 4, fits up to a 2" pin and a drawbar 2-1/2" x 5-1/8" | 463.00 | 314.84 |
| | Choose a Tractor Shaft: | | |
| a) | 340-5505WG Equal Angle Shaft, 1 3/8" x 21 Spline | 1,518.00 | 1,032.24 |
| b) | 340-5509WG Equal Angle Shaft, 1 3/4" x 20 Spline | 1,600.00 | 1,088.00 |

IMPORTANT: PTO Adaptor must not be used in any application.

MASTER PRICE SHEET



Schulte Industries Ltd.

100 John Schulte Dr., Englefeld, SK. Canada, S0K 1N0

Tel: 306-287-3715 Fax: 306-287-3355 Toll Free: 1-800-404-6044

Web: www.Schulte.ca

Sourcewell - Road Right Of Way Maintenance Equipment

MACHINE PRICES AND SPECIFICATIONS

5024 Rotary Cutter



~ ~ Selection 3 ~ Choose a Blade Configuration ~ ~

| | | | | |
|----|----------|-------------------|----------|----------|
| 1) | C524-250 | Two Blade Pan Kit | 7,220.00 | 4,909.60 |
|----|----------|-------------------|----------|----------|

~ ~ Selection 4 ~ Choose a Safety Guard & Accessories ~ ~

| | | | | |
|----|----------|---|----------|----------|
| 1) | C524-575 | Single Safety Chains Front & Rear c/w Front & Rear Half Belting | 4,477.00 | 3,044.36 |
|----|----------|---|----------|----------|

~ ~ Selection 5 ~ Choose Axle Option ~ ~

| | | | | |
|----|----------|--|----------|----------|
| 1) | C502-643 | Standard Axle Kit <i>(Choose 6 Tires cannot use stubble proof tires)</i> | 5,925.00 | 4,029.00 |
| 2) | C502-649 | Standard Axle Kit <i>(Choose 8 Tires cannot use stubble proof tires)</i> | 8,337.00 | 5,669.16 |
| 3) | C502-644 | Walking Axle Kit <i>(Choose 8 Tires cannot use stubble proof tires)</i> | 7,510.00 | 5,106.80 |
| 4) | C502-648 | 618 Walking Axle Kit <i>(Choose 8 tires Stubble proof only)</i> | 8,180.00 | 5,562.40 |

~ ~ Selection 6 ~ Choose Tire Kit ~ ~

| | | | Retail Price/Tire | Contract Price/Tire |
|----|------------|---|-------------------|---------------------|
| 5) | 210-182WG | Aircraft Tire <i>(Choose quantity of tires needed 6 or 8)</i> | 622.00 | 422.96 |
| 6) | 210-182FWG | Foam Filled Aircraft Tire <i>(Choose quantity of tires needed 6 or 8)</i> | 1,102.00 | 749.36 |
| 7) | 210-560WG | Tire Assembly Stubble Proof <i>(Choose quantity of tires needed 6 or 8)</i> | 902.00 | 613.36 |
| 8) | 210-505WG | Light Truck Tire <i>(Choose quantity of tires needed 6 or 8)</i> | 424.00 | 288.32 |

~ ~ Selection 7 ~ Schulte Fan Kit ~ ~

| | | | | |
|----|----------|--|-----------|-----------|
| 1) | C502-780 | Cyclone Fan Debris Kit, Factory Installed | 17,232.00 | 11,717.76 |
| 2) | C502-790 | Cyclone Fan Debris Kit, Crated | 16,988.00 | 11,551.84 |

MASTER PRICE SHEET



Schulte Industries Ltd.

100 John Schulte Dr., Englefeld, SK. Canada, S0K 1N0

Tel: 306-287-3715 Fax: 306-287-3355 Toll Free: 1-800-404-6044

Web: www.Schulte.ca

Sourcewell - Road Right Of Way Maintenance Equipment

MACHINE PRICES AND SPECIFICATIONS

5024 Rotary Cutter



~ ~ Selection 8 ~ Choose a Destination Code ~ ~

Please select the destination of the cutter for proper Decals and Manuals.

| | | | | |
|----|----------------|---|--------------|--------------|
| 1) | C524-NA | North America and Australia Destination Kit | 91.00 | 61.88 |
|----|----------------|---|--------------|--------------|

~ ~ Selection 9 ~ Extra Options ~ ~

| | | | | |
|-------------------------------------|------------------------------|-----------------|------------|-----------------|
| C502-920 | Crop Dividers | 397.00 | | 269.96 |
| C502-740 | HYD Cooler Factory Installed | 7,605.00 | | 5,171.40 |
| C502-745 | HYD Cooler Factory Crated | 7,245.00 | | 4,926.60 |
| C502-625 | Row crop Extension Kit | 598.00 | | 406.64 |
| Assembly charge on pan units | | | Net | 650.00 |



MASTER PRICE SHEET



Schulte Industries Ltd.

100 John Schulte Dr., Englefeld, SK. Canada, S0K 1N0

Tel: 306-287-3715 Fax: 306-287-3355 Toll Free: 1-800-404-6044

Web: www.Schulte.ca

Sourcewell - Road Right Of Way Maintenance Equipment

MACHINE PRICES AND SPECIFICATIONS

FX-520 Rotary Cutter



SPECIFICATIONS

- | | | |
|---|-------------------------------------|---|
| - Overall Width --- 247" (6.2m) | - Transport Width --- 91" (2.32m) | - Min. Tractor Size --- 100hp (75kw) |
| - Overall Length --- 242" (6.15m) | - Transport Height --- 120" (3.05m) | - Blade Tip Speed --- 16,000 ft/min |
| - Cutting Height --- 2" - 17.5" (Depending on Tire Size) | - Cutting Capacity --- 2" (51mm) | - Blade Overlap --- 6" (153mm) |
| - Cutting Width --- 240" (6.10m) | 2" (51mm) Fixed Knife | - Deck Thickness --- .180" (7 ga) (4.6mm) |
| | 4" (102 mm) Pan Unit | |

~ ~ Selection 1 ~ Choose a Basic Unit ~ ~

| | | <i>Retail Price</i> | <i>Contract Price</i> |
|----|--|---------------------|-----------------------|
| 1) | C520-100 Basic 20' Unit, 1000 RPM | 62,835.00 | 42,727.80 |
| 2) | S000-080 Safety Light Kit (Required) | 854.00 | 580.72 |

~ ~ Selection 2 ~ Choose a Hitch Type and Accessories ~ ~

| | | | |
|----|---|-----------------|-----------------|
| 2) | C520-800 Trailing hitch, CV Style | 1,708.00 | 1,161.44 |
| | Choose a Clevis: | | |
| | a) C000-513WG Solid Tongue | 629.00 | 427.72 |
| | b) C000-507WG Open Clevis | 585.00 | 397.80 |
| | c) C000-500WG Precision hitch | 979.00 | 665.72 |
| | d) C000-516WG Solid Tongue with 2-3/16" hole for 2" pin | 1,140.00 | 775.20 |
| | e) C000-515WG Clevis with 2 3/16" Opening | 683.00 | 464.44 |
| | f) C000-510WG Pro Level Hitch | 856.00 | 582.08 |
| | Choose a Tractor Shaft: | | |
| | a) 340-8092WG CV Shaft, 1 3/8" x 21 Spline | 3,050.00 | 2,074.00 |
| | b) 340-8082WG CV Shaft, 1 3/4" x 20 Spline | 3,050.00 | 2,074.00 |

MASTER PRICE SHEET



Schulte Industries Ltd.

100 John Schulte Dr., Englefeld, SK. Canada, S0K 1N0

Tel: 306-287-3715 Fax: 306-287-3355 Toll Free: 1-800-404-6044

Web: www.Schulte.ca

Sourcewell - Road Right Of Way Maintenance Equipment

MACHINE PRICES AND SPECIFICATIONS

FX-520 Rotary Cutter



~ ~ Selection 3 ~ Choose a Blade Configuration ~ ~

| | | | | |
|----|----------|---|----------|----------|
| 1) | C520-250 | Pan Kit with Updraft Blades and Shrouds | 5,910.00 | 4,018.80 |
| 2) | C520-260 | Pan Kit with Shredder Blades and Shrouds | 7,095.00 | 4,824.60 |
| 3) | C520-265 | Fixed Knife Shredder Kit with Updraft Blades & Shrouds | 8,995.00 | 6,116.60 |
| 4) | C520-295 | Fixed Knife Kit with Flat Blades & Shrouds (For Cotton) | 8,735.00 | 5,939.80 |

~ ~ Selection 4 ~ Choose a Safety Guard and Accessories ~ ~

| | | | | |
|----|----------|--|----------|----------|
| 1) | C520-500 | Single chains front and rear | 2,386.00 | 1,622.48 |
| 2) | C520-550 | Double chains front and rear | 2,984.00 | 2,029.12 |
| | a) | C520-580 Half Length Front Belting <i>(Must be used with a chain option)</i> | 821.00 | 558.28 |

~ ~ Selection 5 ~ Choose Axle and Tire Option ~ ~

| | | | | |
|----|----------|--|----------|----------|
| 1) | C520-612 | Standard 618 Axle kit <i>(Choose 4 Tires - Stubble Proof Only)</i> | 6,473.00 | 4,401.64 |
| 2) | C520-614 | 517 Axle Kit c/w Center duals <i>(choose 6 Tires)</i> | 6,667.00 | 4,533.56 |
| 3) | C520-616 | 517 Axle Kit c/w Center Walking <i>(choose 6 Tires)</i> | 7,203.00 | 4,898.04 |
| 4) | C520-618 | 517 Dual Axle Kit <i>(Choose 8 Tires)</i> | 7,533.00 | 5,122.44 |
| 5) | C520-622 | 517 Walking Axle kit <i>(Choose 8 Tires)</i> | 8,685.00 | 5,905.80 |
| 6) | C520-624 | 517 Center Walking Axle c/w Duals on Wings <i>(Choose 8 Tires)</i> | 8,046.00 | 5,471.28 |

~ ~ Selection 6 ~ Choose Axle and Tire Option ~ ~

| | | | Retail Price/Tire | Contract Price/Tire |
|-----|------------|--|-------------------|---------------------|
| 7) | 210-560WG | Tire Assembly Stubble Proof <i>(Can only be used with C520-612)</i> | 902.00 | 613.36 |
| 8) | 210-182WG | Aircraft Tire <i>(Choose quantity of tires needed, 6 or 8)</i> | 622.00 | 422.96 |
| 9) | 210-182FWG | Foam Filled Aircraft Tire <i>(Choose quantity of tires needed, 6 or 8)</i> | 1,102.00 | 749.36 |
| 10) | 210-505WG | Light Truck Tire <i>(Choose quantity of tires needed, 6 or 8)</i> | 424.00 | 288.32 |

MASTER PRICE SHEET



Schulte Industries Ltd.

100 John Schulte Dr., Englefeld, SK. Canada, S0K 1N0

Tel: 306-287-3715 Fax: 306-287-3355 Toll Free: 1-800-404-6044

Web: www.Schulte.ca

Sourcewell - Road Right Of Way Maintenance Equipment

MACHINE PRICES AND SPECIFICATIONS

FX-520 Rotary Cutter



~ ~ **Selection 7 ~ Choose a Destination Code** ~ ~

| | | | | |
|----|---------|---|---------------|--------------|
| 1) | C520-NA | North America and Australia Destination Kit | 125.00 | 85.00 |
|----|---------|---|---------------|--------------|

~ ~ **Selection 8 ~ Schulte Fan Kit** ~ ~

| | | | | |
|----|----------|--|------------------|------------------|
| 1) | C520-780 | Fan Debris Kit, <i>Factory Installed</i> | 16,728.00 | 11,375.04 |
| 2) | C520-790 | Fan Debris Kit, <i>Crated</i> | 16,391.00 | 11,145.88 |

| | | |
|--------------------------------------|------------|---------------|
| Assembly charge on pan units | Net | 650.00 |
| Assembly charge on fixed blade units | Net | 750.00 |



MASTER PRICE SHEET



Schulte Industries Ltd.

100 John Schulte Dr., Englefeld, SK. Canada, S0K 1N0

Tel: 306-287-3715 Fax: 306-287-3355 Toll Free: 1-800-404-6044

Web: www.Schulte.ca

Sourcewell - Road Right Of Way Maintenance Equipment

MACHINE PRICES AND SPECIFICATIONS

FX-320 Pan & Fixed Knife Rotary Cutter



SPECIFICATIONS

- | | | |
|---|---|--|
| - Overall Width --- 249" (6.32m) | - Transport Width --- 98" (2.49m) | - Min. Tractor Size --- 100hp (75kw) |
| - Overall Length --- 242" (6.15m) | - Transport Height --- 100" (2.55m) | - Blade Tip Speed --- 16,031 ft/min (540 RPM) |
| - Cutting Height --- 2" - 19.5" (Depending on Tire Size) | - Cutting Capacity --- 2" (51mm) 2" (51mm) Fixed Knife | - Blade Tip Speed --- 16,289 ft/min (1000 RPM) |
| - Cutting Width --- 240" (6.10m) | 4" (102 mm) Pan Unit | - Blade Overlap --- 6" (153mm) |
| | | - Deck Thickness --- .180" (7 ga) (4.6mm) |

~ ~ Selection 1 ~ Choose a Basic Unit ~ ~

| | | <i>Retail Price</i> | <i>Contract Price</i> |
|----|---|---------------------|-----------------------|
| 1) | C321-100 FX320 Base Unit | 38,527.00 | 26,198.36 |
| 2) | S000-170 Safety Light Kit (Required) | 1,086.00 | 738.48 |
| | Choose a Drive Package: | | |
| a) | C321-700 Drive Package, CW Center, 540 RPM | 9,699.00 | 6,595.32 |
| b) | C321-705 Drive Package, CW Center, 1000 RPM | 9,699.00 | 6,595.32 |
| | Choose Independent Wing Lift: | | |
| a) | C321-310 Independent Wing Lift Kit (Required) | 276.00 | 187.68 |

~ ~ Selection 2 ~ Choose a Hitch Type and Accessories ~ ~

| | | | |
|----|--|-----------------|-----------------|
| 1) | C185-180 Trailing hitch, CV Style | 1,219.00 | 828.92 |
| | Choose a Clevis: | | |
| a) | C000-513WG Solid Tongue | 629.00 | 427.72 |
| b) | C000-507WG Open Clevis | 585.00 | 397.80 |
| c) | C000-500WG Precision hitch | 979.00 | 665.72 |
| d) | C000-516WG Solid Tongue with 2-3/16" hole for 2" pin | 1,140.00 | 775.20 |
| e) | C000-515WG Clevis with 2 3/16" Opening | 683.00 | 464.44 |
| f) | C000-510WG Pro Level Hitch | 856.00 | 582.08 |
| | Choose a Tractor Shaft: | | |
| a) | 340-870WG CV Shaft, 540 RPM | 2,234.00 | 1,519.12 |
| b) | 340-648WG CV Shaft, 1000 RPM | 1,850.00 | 1,258.00 |
| c) | 340-658WG CV Shaft 1000 RPM 1 3/4" shaft | 2,437.00 | 1,657.16 |
| 2) | C185-196 Equal Angle Hitch Kit w/ 540 RPM Shaft c/w Non CV Drive Shaft | 3,966.00 | 2,696.88 |

MASTER PRICE SHEET



Schulte Industries Ltd.

100 John Schulte Dr., Englefeld, SK. Canada, S0K 1N0

Tel: 306-287-3715 Fax: 306-287-3355 Toll Free: 1-800-404-6044

Web: www.Schulte.ca

Sourcewell - Road Right Of Way Maintenance Equipment

MACHINE PRICES AND SPECIFICATIONS

FX-320 Pan & Fixed Knife Rotary Cutter



~ ~ Selection 3 ~ Choose a Blade Configuration ~ ~

| | | | | |
|----|----------|---|----------|----------|
| 1) | C321-450 | Pan Kit, 4" Blades | 5,225.00 | 3,553.00 |
| 2) | C321-455 | Pan Kit, 5" Blades | 5,362.00 | 3,646.16 |
| 3) | C321-475 | Fixed Knives Only <i>(Select Shrouding Kit Listed Below w/ Fixed Knife Kit)</i> | 5,100.00 | 3,468.00 |
| 4) | C321-480 | Shrouding Kit <i>(Shrouds only)</i> | 971.00 | 660.28 |

~ ~ Selection 4 ~ Choose a Safety Guard and Accessories ~ ~

| | | | | |
|----|----------|-----------------------------------|----------|----------|
| 1) | C321-500 | Single Safety Chains Front & Rear | 2,650.00 | 1,802.00 |
| 2) | C321-510 | Double Safety Chains Front & Rear | 2,950.00 | 2,006.00 |
| 3) | C321-550 | Front Half Belting | 992.00 | 674.56 |
| 4) | C321-560 | Rear Half Belting | 980.00 | 666.40 |

~ ~ Selection 5 ~ Choose Axle and Tire Option ~ ~

Choose a Walking Axle Configuration, or Move down to Non Walking

| | | | | |
|---|----------|---|----------|----------|
| 1) | C350-820 | Walking Axle Mounts <i>(4 tire kit, axles included)</i> | 2,666.00 | 1,812.88 |
| Choose 2 if wanting center & wings both walking, or choose 1 if you are wanting only center walking axles | | | | |
| 2) | C350-830 | Non Walking Wing Axles <i>(2 Tire Kit, Axles Included)</i> | 1,104.00 | 750.72 |
| 3) | C350-825 | Non Walking Wing Axles <i>(4 Tire Kit, Axles Included)</i> | 1,564.00 | 1,063.52 |
| <u>Or Choose a non walking axle kit below</u> | | | | |
| 4) | C321-865 | Non Walking Wheel Standards - 8 Tires <i>(517 Hub - Center & Wings)</i> | 3,160.00 | 2,148.80 |
| 5) | C321-870 | Non Walking Wheel Standards - 6 Tires <i>(517 Hub - Center & Wings)</i> | 2,775.00 | 1,887.00 |
| 6) | C321-875 | Non Walking Wheel Standards - 4 Tires <i>(618 Hub - Center & Wings)</i> | 2,775.00 | 1,887.00 |

~ ~ Selection 6 ~ Choose Axle and Tire Option ~ ~

| | | | Retail Price/Tire | Contract Price/Tire |
|----|------------|---|-------------------|---------------------|
| 1) | 210-560WG | Tire Assembly Stubble Proof <i>(Can only be used with C321-875)</i> | 902.00 | 613.36 |
| 2) | 210-540WG | Tire 24x8-14 20 Ply Rated Severe Duty | 622.00 | 422.96 |
| 3) | 210-540FWG | Tire 24x8-14 20 Ply Rated Severe Duty Foam Filled | 981.00 | 667.08 |
| 4) | 210-505WG | Light Truck Tire (ST205/90D-15/8 Ply) | 424.00 | 288.32 |
| 5) | 210-192WG | Solid Laminated Tire, 6 x 9 x 26 | 609.00 | 414.12 |

MASTER PRICE SHEET



Schulte Industries Ltd.

100 John Schulte Dr., Englefeld, SK. Canada, S0K 1N0

Tel: 306-287-3715 Fax: 306-287-3355 Toll Free: 1-800-404-6044

Web: www.Schulte.ca

Sourcewell - Road Right Of Way Maintenance Equipment

MACHINE PRICES AND SPECIFICATIONS

FX-320 Pan & Fixed Knife

Rotary Cutter



~ ~ **Selection 7 ~ Choose a Destination Code** ~ ~

| | | | | |
|----|---------|---|---------------|---------------|
| 1) | C321-NA | North America and Australia Destination Kit | 136.00 | 92.48 |
| | | Assembly charge on pan units | Net | 400.00 |
| | | Assembly charge on fixed blade units | Net | 500.00 |



MASTER PRICE SHEET



Schulte Industries Ltd.

100 John Schulte Dr., Englefeld, SK. Canada, S0K 1N0

Tel: 306-287-3715 Fax: 306-287-3355 Toll Free: 1-800-404-6044

Web: www.Schulte.ca

Sourcewell - Road Right Of Way Maintenance Equipment

MACHINE PRICES AND SPECIFICATIONS

FX-318 Rotary Cutter (Pan Unit)



CUTTER FEATURES

- 540/1000 RPM 80° CV Drive
- 540 Equal angle non cv drive
- 7 ga Single Domed Deck and Stump Jumpers
- Rubber 3 Puck Grommet Suspension Height
- 90 HP Recommended Tractor
- Cutting Width 216" (5.5m)
- Replaceable Skid Shoes
- Height Control Cylinder & Hoses
- Wing Lift Cylinders & Hoses
- 1.75" to 16.75" (44.5mm to 425mm) Cutting
- Over Center Folding Wings
- Transport Width (max with duals on wings)

~ ~ Selection 1 ~ Choose a Basic Unit, Drive Package ~ ~

| | | Retail Price | Contract Price |
|-------------------------|---|--------------|----------------|
| C318-100 | Schulte FX-318, Basic Unit | 29,196.00 | 19,853.28 |
| S000-085 | Safety Light Kit (Required) | 814.00 | 553.52 |
| Choose a Drive Package: | | | |
| a) | C318-735 Drive Package, CW Center, 540 RPM | 9,050.00 | 6,154.00 |
| b) | C318-720 Drive Package, CW Center, 1000 RPM | 9,050.00 | 6,154.00 |

~ ~ Selection 2 ~ Trailing Hitch ~ ~

Note: It using Equal Angle Hitch Skip to Selection 3

| | | | |
|--------------------|--|----------|----------|
| C185-180 | Trailing Hitch, CV Style <i>Required</i> | 1,219.00 | 828.92 |
| Choose a CV Shaft: | | | |
| a) | 340-870WG CV Shaft, 540 RPM | 2,234.00 | 1,519.12 |
| b) | 340-648WG CV Shaft, 1000 RPM | 1,850.00 | 1,258.00 |
| c) | 340-658WG CV Shaft 1000 RPM 1 3/4" shaft | 2,437.00 | 1,657.16 |
| Choose a Clevis: | | | |
| C000-506WG | Open Clevis (Minimum Requirments) | 541.00 | 367.88 |
| C000-500WG | Precision hitch | 979.00 | 665.72 |
| C000-513WG | Solid Tongue | 629.00 | 427.72 |
| C000-510WG | Pro Level Hitch | 856.00 | 582.08 |

~ ~ Selection 3 ~ Equal Angle Clevis ~ ~

| | | | |
|----------|---|----------|----------|
| C185-196 | Equal Angle Hitch Kit w/ 540 RPM Shaft c/w Non CV Drive Shaft | 3,966.00 | 2,696.88 |
|----------|---|----------|----------|

MASTER PRICE SHEET



Schulte Industries Ltd.

100 John Schulte Dr., Englefeld, SK. Canada, S0K 1N0

Tel: 306-287-3715 Fax: 306-287-3355 Toll Free: 1-800-404-6044

Web: www.Schulte.ca

Sourcewell - Road Right Of Way Maintenance Equipment

MACHINE PRICES AND SPECIFICATIONS

FX-318 Rotary Cutter (Pan Unit)



~ ~ Selection 4 ~ Choose a Chain Guards ~ ~

| | | | |
|----------|--|----------|----------|
| C318-500 | Chain Guards Single Front and Rear | 2,183.00 | 1,484.44 |
| C318-550 | Chain Guards Double Front and Rear | 2,690.00 | 1,829.20 |
| C318-560 | Front Half Belting <i>(Must be used with a chain option)</i> | 815.00 | 554.20 |
| C318-570 | Rear Half Belting <i>(Must be used with a chain option)</i> | 775.00 | 527.00 |

~ ~ Selection 5 ~ Choose a Pan Kit ~ ~

| | | | |
|----------|--------------------|----------|----------|
| C318-450 | Pan Kit (required) | 3,307.00 | 2,248.76 |
|----------|--------------------|----------|----------|

~ ~ Selection 6 ~ Choose a Blade Configuration ~ ~

| | | | |
|----------|--|----------|--------|
| C318-460 | Updraft Blades, CW Center | 818.00 | 556.24 |
| C318-465 | Super Updraft 5" Blades CW Center | 953.00 | 648.04 |
| C318-470 | Shredder Blades, CW Center <i>(optional)</i> | 1,340.00 | 911.20 |

~ ~ Selection 7 ~ Choose Both Wheel Standard Kits ~ ~

| | | | |
|----------|---|----------|----------|
| C318-810 | Wing Wheel Standard, 1 or 2 Tires <i>Required</i> | 1,343.00 | 913.24 |
| C318-800 | Dual Wheel Standard on the Center <i>Required</i> | 1,600.00 | 1,088.00 |

~ ~ Selection 8 ~ Choose a Axle Kit ~ ~

| | | | |
|----------|----------------------|----------|----------|
| C180-484 | Axle Kit for 4 Tires | 997.00 | 677.96 |
| C180-486 | Axle Kit for 6 Tires | 1,582.00 | 1,075.76 |
| C180-488 | Axle Kit for 8 Tires | 2,245.00 | 1,526.60 |

~ ~ Selection 9 ~ Choose a Tire Option ~ ~

Please state the quantity of tires that you would like to order as the numbers listed below are single tires and not tire kits.

| | | Retail Price/Tire | Contract Price/Tire |
|------------|---|-------------------|---------------------|
| 210-003WG | Solid Laminated Tires, 6 x 9 x 20 | 380.00 | 258.40 |
| 210-175WG | Forklift Tire 6.5 x 10 - 12 ply on 2 pce 5 bolt rim | 533.00 | 362.44 |
| 210-175FWG | Foam Filled Forklift Tire 6.5 x 10 - 12 ply on 2 pce 5 bolt rim | 924.00 | 628.32 |
| 210-540WG | Tire 24x8-14 20 Ply Rated Severe Duty | 622.00 | 422.96 |
| 210-540FWG | Tire 24x8-14 20 Ply Rated Severe Duty Foam Filled | 981.00 | 667.08 |
| 210-192WG | Solid Laminated Tire, 6 x 9 x 26 | 609.00 | 414.12 |

MASTER PRICE SHEET



Schulte Industries Ltd.

100 John Schulte Dr., Englefeld, SK. Canada, S0K 1N0

Tel: 306-287-3715 Fax: 306-287-3355 Toll Free: 1-800-404-6044

Web: www.Schulte.ca

Sourcewell - Road Right Of Way Maintenance Equipment

MACHINE PRICES AND SPECIFICATIONS

FX-318 Rotary Cutter (Pan Unit)



~ ~ Selection 10 ~ Choose a Destination Code ~ ~

| | | | |
|---------|---------------------------------------|-------|-------|
| C318-NA | North American & Australian Decal Kit | 83.00 | 56.44 |
|---------|---------------------------------------|-------|-------|

~ ~ Selection 11 ~ Choose Extra Options ~ ~

| | | | |
|----------|-----------------------|--------|--------|
| C185-310 | Independent Wing Lift | 276.00 | 187.68 |
| | Assembly Charge | Net | 400.00 |



MASTER PRICE SHEET



Schulte Industries Ltd.

100 John Schulte Dr., Englefeld, SK. Canada, S0K 1N0

Tel: 306-287-3715 Fax: 306-287-3355 Toll Free: 1-800-404-6044

Web: www.Schulte.ca

Sourcewell - Road Right Of Way Maintenance Equipment

MACHINE PRICES AND SPECIFICATIONS

FX-212 Rotary Cutter



CUTTER FEATURES

- 540/1000 RPM 80° CV Drive
- 540 Equal angle non cv drive
- 7 ga Single Domed Deck and Stump Jumpers
- Rubber 3 Puck Grommet Suspension
- 90 HP Recommended Tractor
- Cutting Width 144-1/2" (3.65m)
- Replaceable Skid Shoes
- Height Control Cylinder & Hoses
- Wing Lift Cylinders & Hoses
- 1.75" to 16.75" (44.5mm to 425mm) Cutting Height
- Over Center Folding Wing
- Transport Width 87"(2.4m)

~ ~ Selection 1 ~ Choose a Basic Unit, Drive Package ~ ~

| | | Retail Price | Contract Price |
|-----------------------------------|--|--------------|----------------|
| C319-100 | FX-212, Basic Unit | 27,384.00 | 18,621.12 |
| S000-085 | Safety Light Kit (Required) | 814.00 | 553.52 |
| <i>DRIVE PACKAGE (choose one)</i> | | | |
| C319-735 | CW Rotation on Center, 540 RPM G8 Shaft | 6,179.00 | 4,201.72 |
| C319-720 | CW Rotation on Center, 1000 RPM G8 Shaft | 6,179.00 | 4,201.72 |

~ ~ Selection 2 ~ Choose a Hitch Option ~ ~

| | | | |
|--------------------|--|----------|----------|
| C185-180 | Trailing Hitch, CV Style | 1,219.00 | 828.92 |
| Choose a CV Shaft: | | | |
| a) 340-870WG | CV Shaft, 540 RPM | 2,234.00 | 1,519.12 |
| b) 340-648WG | CV Shaft, 1000 RPM | 1,850.00 | 1,258.00 |
| C185-196 | Equal Angle Hitch Kit w/ 540 RPM Shaft | 3,966.00 | 2,696.88 |

~ ~ Selection 3 ~ Choose a Clevis ~ ~

| | | | |
|------------|------------------------------------|--------|--------|
| C000-506WG | Open Clevis (Minimum Requirements) | 541.00 | 367.88 |
| C000-500WG | Precision hitch | 979.00 | 665.72 |
| C000-510WG | Pro Level Hitch | 856.00 | 582.08 |
| C000-513WG | Solid Tongue | 629.00 | 427.72 |

~ ~ Selection 4 ~ Choose Axle Kits ~ ~

| | | | |
|----------|--|----------|----------|
| C319-810 | Single Axle Kit for Right Wing (required) (accommodates 1 or 2 tires) | 572.00 | 388.96 |
| C318-800 | Duals Wheel Standard on Center (Required) | 1,600.00 | 1,088.00 |

PREDELIVERY SERVICE IS REQUIRED BY DEALER OR END USER

MASTER PRICE SHEET



Schulte Industries Ltd.

100 John Schulte Dr., Englefeld, SK. Canada, S0K 1N0

Tel: 306-287-3715 Fax: 306-287-3355 Toll Free: 1-800-404-6044

Web: www.Schulte.ca

Sourcewell - Road Right Of Way Maintenance Equipment

MACHINE PRICES AND SPECIFICATIONS

FX-212 Rotary Cutter



~ ~ Selection 5 ~ Choose a Safety Guard ~ ~

| | | | |
|----------|--|----------|----------|
| C319-500 | Chain Guards Single Front & Rear | 1,299.00 | 883.32 |
| C319-550 | Chain Guards Double Front & Rear | 1,725.00 | 1,173.00 |
| C319-560 | Front Half Belting <i>(Must be used with chain guards)</i> | 602.00 | 409.36 |
| C319-570 | Rear Half Belting <i>(Must be used with chain guards)</i> | 544.00 | 369.92 |

~ ~ Selection 6 ~ Choose The Pan Kit ~ ~

| | | | |
|----------|--------------------|----------|----------|
| C319-450 | Pan Kit (required) | 2,141.00 | 1,455.88 |
|----------|--------------------|----------|----------|

~ ~ Selection 7 ~ Choose a Blade Configuration ~ ~

| | | | |
|----------|---------------------------|--------|--------|
| C319-460 | Updraft Blades, CW Center | 550.00 | 374.00 |
|----------|---------------------------|--------|--------|

~ ~ Selection 8 ~ Choose an Axle Kit ~ ~

| | | | |
|----------|----------------------|----------|----------|
| C190-485 | Axle Kit for 5 Tires | 1,377.00 | 936.36 |
| C180-486 | Axle Kit for 6 Tires | 1,582.00 | 1,075.76 |

~ ~ Selection 9 ~ Choose a Tire Option ~ ~

Please state the quantity of tires that you would like to order as the numbers listed below are single tires and not tire kits.

| | | | |
|------------|---|--------|--------|
| 210-003WG | Solid Laminated Tires, 6 x 9 x 20 | 380.00 | 258.40 |
| 210-175WG | Tire Assy, Forklift, 6.5 x 10 - 12 ply on 2 pce 5 bolt rim | 533.00 | 362.44 |
| 210-175FWG | Foam Filled Forklift Tire 6.5 x 10 - 12 ply on 2 pce 5 bolt rim | 924.00 | 628.32 |
| 210-540WG | Tire 24x8-14 20 Ply Rated Severe Duty | 622.00 | 422.96 |
| 210-540FWG | Tire 24x8-14 20 Ply Rated Severe Duty Foam Filled | 981.00 | 667.08 |
| 210-192WG | Solid Laminated Tire, 6 x 9 x 26 | 609.00 | 414.12 |

~ ~ Selection 10 ~ Choose a Destination Code ~ ~

| | | | |
|---------|---------------------------------------|-------|--------|
| C319-NA | North American & Australian Decal Kit | 80.00 | 54.40 |
| | Assembly Charge | Net | 300.00 |

PREDELIVERY SERVICE IS REQUIRED BY DEALER OR END USER



MASTER PRICE SHEET



Schulte Industries Ltd.

100 John Schulte Dr., Englefeld, SK. Canada, S0K 1N0
 Tel: 306-287-3715 Fax: 306-287-3355 Toll Free: 1-800-404-6044
 Web: www.Schulte.ca

Sourcewell - Road Right Of Way Maintenance Equipment

MACHINE PRICES AND SPECIFICATIONS

TPX-318 3PT FOLDING FLEX WING



CUTTER FEATURES

- 1000 RPM CV Drive
- Heavy duty rubber coupler on drive line
- Fold up design for narrow transport width
- Greasable bushings
- Easy height adjustment
- Double acting wings
- Only one hydraulic circuit needed
- 2" to 17" Cutting Height

~ ~ Selection 1 ~ Choose a Basic Unit, Drive Package ~ ~

| | | Retail Price | Contract Price |
|----------|---|--------------|----------------|
| C380-100 | TPX-318 Base Unit c/w Fixed Knife Mulching System (Cotton, Corn, Sugar Cane Stalks) | 43,840.00 | 29,811.20 |

~ ~ Selection 2 ~ Choose a Tractor Shaft ~ ~

| | | | |
|-----------|-----------------|----------|----------|
| 340-829WG | Solid Tongue | 2,345.00 | 1,594.60 |
| 340-833WG | Pro Level Hitch | 2,345.00 | 1,594.60 |

~ ~ Selection 3 ~ Choose a Blade Option ~ ~

| | | | |
|----------|----------------------------------|----------|--------|
| C380-400 | Blades, Schulte Standard Updraft | 1,127.00 | 766.36 |
|----------|----------------------------------|----------|--------|

~ ~ Selection 4 ~ Choose a Belting Option ~ ~

| | | | |
|----------|-----------------------|--------|--------|
| C380-530 | TPX-318 Front Belting | 700.00 | 476.00 |
| C380-540 | TPX-318 Rear Belting | 700.00 | 476.00 |

~ ~ Selection 5 ~ Choose an Axle Style ~ ~

| | | | |
|----------|----------------------------|----------|----------|
| C380-480 | TPX318 Solid Wheel Option | 2,229.00 | 1,515.72 |
| C380-485 | TPX318 Castor Wheel Option | 4,380.00 | 2,978.40 |

~ ~ Selection 6 ~ Choose a Tire Option ~ ~

(CHOOSE 4 TIRES PER UNIT, 2 LEFT & 2 RIGHT)

| | | | |
|-----------|--|--------|--------|
| 210-186WG | 27 X 10.5-15 Skid Steer Tire, LEFT | 588.00 | 399.84 |
| 210-187WG | 27 X 10.5-15 Skid Steer Tire, RIGHT | 588.00 | 399.84 |

~ ~ Selection 7 ~ Choose a Destination Code ~ ~

| | | | |
|---------|---------------------------------------|-------|--------|
| C380-NA | North American & Australian Decal Kit | 82.00 | 55.76 |
| | Assembly Charge | Net | 400.00 |

PREDELIVERY SERVICE IS REQUIRED BY DEALER OR END USER



MASTER PRICE SHEET



Schulte Industries Ltd.

100 John Schulte Dr., Englefeld, SK. Canada, S0K 1N0

Tel: 306-287-3715 Fax: 306-287-3355 Toll Free: 1-800-404-6044

Web: www.Schulte.ca

Sourcewell - Road Right Of Way Maintenance Equipment

MACHINE PRICES AND SPECIFICATIONS

XH1500 Series 5 Rotary Cutter



CUTTER FEATURES

- 7GA deck
- Replaceable skid shoes
- Double safety chains front & rear
- Hydraulic phasing lift system
- Hydraulic wing lift system
- 517 Hubs and axles
- Single domed, sweep clean deck
- Rubber suspension - standard
- Four gearbox drive layout
- 240hp down, 275hp splitter
- Full floating front hitch
- Deck protection rings
- S000-010 safety chain kit 1/4" grade 70 with 10,000 lbs capacity
- 1/4" Round skid pans (Stump Jumpers)
- Pentagon blade bolt design
- Operator's manual in holder

~ ~ Selection 1 ~ Choose a Basic Unit ~ ~

| | | Retail Price | Contract Price |
|-------------------------|---|--------------|----------------|
| 1) | C350-100 Basic Unit XH Series 5 | 27,022.00 | 18,374.96 |
| 2) | C350-200 15' Option (Required) | 20,821.00 | 14,158.28 |
| 3) | S000-160 Safety Light Kit (Required) | 1,059.00 | 720.12 |
| 4) | C301-830 ISO Couplers (Required) | 91.00 | 61.88 |
| Choose a Drive Package: | | | |
| a) | C350-705 CW Rotation Center 540 RPM (Std. Rotation) | 8,765.00 | 5,960.20 |
| b) | C350-715 CW Rotation Center 1000 RPM (Std. Rotation) | 8,765.00 | 5,960.20 |
| c) | C350-700 OR CCW Rotation on Center 540 RPM (Non Std Rotation) | 8,765.00 | 5,960.20 |
| d) | C350-710 OR CCW Rotation on Center 1000 RPM (Non Std. Rotation) | 8,765.00 | 5,960.20 |

~ ~ Selection 2 ~ Choose a Hitch Type and Accessories ~ ~

| | | | |
|-------------------------|---|----------|----------|
| 1) | C350-180 Trailing Hitch CV Style | 1,284.00 | 873.12 |
| Choose a Clevis: | | | |
| a) | C000-506WG Open Clevis (Minimum Requirement with a Flex Arm) | 541.00 | 367.88 |
| b) | C000-500WG Precision Hitch (Can be used with a Flex Arm) | 979.00 | 665.72 |
| c) | C000-513WG Solid tongue (Can be used with a Flex Arm) | 629.00 | 427.72 |
| d) | C000-515WG Clevis 2 3/16 " opening (Can be used with a Flex Arm) | 683.00 | 464.44 |
| e) | C000-510WG Pro Level Hitch (Can <u>NOT</u> be used with a Flex Arm) | 856.00 | 582.08 |
| Choose a Tractor Shaft: | | | |
| a) | 340-870WG CV Shaft, 540 rpm | 2,234.00 | 1,519.12 |
| b) | 340-648WG CV Shaft, 1000 rpm | 1,850.00 | 1,258.00 |
| c) | 340-658WG CV Shaft 1000 RPM 1 3/4" shaft | 2,437.00 | 1,657.16 |
| 2) | C350-196 Equal Angle Hitch Kit w/ 540 RPM Shaft | 3,964.00 | 2,695.52 |

~ ~ Selection 3 ~ Choose Hydraulic Option ~ ~

| | | | |
|----|--|--------|--------|
| 1) | C350-805 Independent Double Acting Hose Kit OR | 474.00 | 322.32 |
| 2) | C350-810 Double Acting Hose Kit | 426.00 | 289.68 |

MASTER PRICE SHEET



Schulte Industries Ltd.

100 John Schulte Dr., Englefeld, SK. Canada, S0K 1N0

Tel: 306-287-3715 Fax: 306-287-3355 Toll Free: 1-800-404-6044

Web: www.Schulte.ca

Sourcewell - Road Right Of Way Maintenance Equipment

MACHINE PRICES AND SPECIFICATIONS

XH1500 Series 5 Rotary Cutter



~ ~ Selection 4 ~ Choose a Blade Configuration ~ ~

| | | | | |
|----|----------|---|--------|--------|
| 1) | C350-450 | 2 Blade Pan Kit - cw Schulte Super Suction Updraft 4" Blades | 550.00 | 374.00 |
| 2) | C350-451 | 2 Blade Pan Kit - ccw Schulte Super Suction Updraft 4" Blades | 550.00 | 374.00 |
| 3) | C350-455 | 2 Blade Pan Kit - cw Schulte Super Suction Updraft 5" Blades | 650.00 | 442.00 |
| 4) | C350-456 | 2 Blade Pan Kit - ccw Schulte Super Suction Updraft 5" Blades | 650.00 | 442.00 |

~ ~ Selection 5 ~ Choose a Center Axle Kit ~ ~

| | | | | |
|----|----------|---|----------|----------|
| 1) | C350-820 | Walking (Axles Included) | 2,666.00 | 1,812.88 |
| 2) | C350-825 | Non Walking (4 Tire Kit, Axles Included) | 1,564.00 | 1,063.52 |
| 3) | C350-350 | Large Tire Option - Center Section (2 tires) | 4,364.00 | 2,967.52 |

C350-350 Includes mounts & tires - Only select tires for the wing axle option

~ ~ Selection 6 ~ Choose a Wing Axle Kit ~ ~

| | | | | |
|----|----------|---|----------|----------|
| 1) | C350-820 | Walking (Axles Included) | 2,666.00 | 1,812.88 |
| 2) | C350-830 | Non Walking (2 Tire Kit, Axles Included) | 1,104.00 | 750.72 |
| 3) | C350-825 | Non Walking (4 Tire Kit, Axles Included) | 1,564.00 | 1,063.52 |

~ ~ Selection 7 ~ Choose a Tire Option ~ ~

Please state the quantity of tires that you would like to order as the numbers listed below are just single tires and not a tire kit.

| | | | Retail Price/Tire | Contract Price/Tire |
|---|------------|---|-------------------|---------------------|
| 1) | 210-186WG | 27 X 10.5-15 Skid Steer Tire, LEFT | 588.00 | 399.84 |
| 2) | 210-187WG | 27 X 10.5-15 Skid Steer Tire, RIGHT | 588.00 | 399.84 |
| 3) | 210-186FWG | Foam Filled, 27 X 10.5-15 Skid Steer Tire, LEFT | 1,397.00 | 949.96 |
| 4) | 210-187FWG | Foam Filled, 27 X 10.5-15 Skid Steer Tire, RIGHT | 1,397.00 | 949.96 |
| NOTE: If choosing skid steer tires, be sure to choose correct amount of left & right tires | | | | |
| 5) | 210-182WG | Aircraft Tire (29 x 9-15/16 Ply) | 622.00 | 422.96 |
| 6) | 210-182FWG | Foam Filled Aircraft Tire (29 x 9-15/16 Ply) | 1,102.00 | 749.36 |
| 7) | 210-192WG | Solid Laminated Tire, 6 x 9 x 26 | 609.00 | 414.12 |

~ ~ Selection 8 ~ Choose a Destination Package ~ ~

Please select the destination of the cutter for proper Decals, Manuals, and Shielding

| | | | | |
|----|---------|--|-------|-------|
| 1) | C350-NA | North American/ Australia Destination Kits | 84.00 | 57.12 |
|----|---------|--|-------|-------|

MASTER PRICE SHEET



Schulte Industries Ltd.

100 John Schulte Dr., Englefeld, SK. Canada, S0K 1N0

Tel: 306-287-3715 Fax: 306-287-3355 Toll Free: 1-800-404-6044

Web: www.Schulte.ca

Sourcewell - Road Right Of Way Maintenance Equipment

MACHINE PRICES AND SPECIFICATIONS

XH1500 Series 5 Rotary Cutter



~ ~ Selection 9 ~ Extra Options ~ ~

| | | | | |
|------------------------|----------|----------------------------|-----------------|---------------|
| 1) | C350-540 | Rear Half Belting Kit | 956.00 | 650.08 |
| 2) | C308-890 | Tire Bumper Kit | 1,066.00 | 724.88 |
| 3) | C350-880 | Right Hand Gauge Wheel Kit | 1,026.00 | 697.68 |
| 4) | C350-885 | Left Hand Gauge Wheel Kit | 1,026.00 | 697.68 |
| 5) | C306-305 | Flex Arm Mount | 244.00 | 165.92 |
| 6) | C000-620 | Toolbox Mount & Toolbox | 1,466.00 | 996.88 |
| Assembly Charge | | | Net | 400.00 |

OPTIONAL PDI INCLUDES: greasing of all pivot points, gearbox oil checked, charge hydraulic cylinders and install pioneer ends. Tires will be installed where necessary. It is the dealers responsibility to remove shipping brackets & banding as well as to adjust mower height as specified in the operators manual. Please go to the Schulte website/dealer access for further information.

PREDELIVERY SERVICE IS REQUIRED BY DEALER OR END USER



MASTER PRICE SHEET



Schulte Industries Ltd.

100 John Schulte Dr., Englefeld, SK. Canada, S0K 1N0

Tel: 306-287-3715 Fax: 306-287-3355 Toll Free: 1-800-404-6044

Web: www.Schulte.ca

Sourcewell - Road Right Of Way Maintenance Equipment

MACHINE PRICES AND SPECIFICATIONS

XH1500 Series 5 Rotary Cutter

SFT Pro Drivelines



CUTTER FEATURES

- 7GA deck
- Replaceable skid shoes
- Double safety chains front & rear
- Hydraulic phasing lift system
- Hydraulic wing lift system
- 517 Hubs and axles
- Single domed, sweep clean deck
- Rubber suspension - standard
- Four gearbox drive layout
- 240hp down, 275hp splitter
- Full floating front hitch
- Deck protection rings
- S000-010 safety chain kit 1/4" grade 70 with 10,000 lbs capacity
- 1/4" Round skid pans (Stump Jumpers)
- Pentagon blade bolt design
- Operator's manual in holder

~ ~ Selection 1 ~ Choose a Basic Unit ~ ~

| | | Retail Price | Contract Price |
|-------------------------|---|--------------|----------------|
| 1) | C350-100 Basic Unit XH Series 5 | 27,022.00 | 18,374.96 |
| 2) | C350-200 15' Option (Required) | 20,821.00 | 14,158.28 |
| 3) | S000-160 Safety Light Kit (Required) | 1,059.00 | 720.12 |
| 4) | C301-830 ISO Couplers (Required) | 91.00 | 61.88 |
| Choose a Drive Package: | | | |
| a) | C350-705PRO SFT Pro Package - CW Rotation Center 540 RPM (Std. Rotation) | 12,995.00 | 8,836.60 |
| b) | C350-715PRO SFT Pro Package - CW Rotation Center 1000 RPM (Std. Rotation) | 12,995.00 | 8,836.60 |
| c) | C350-700PRO SFT Pro Package - CCW Rotation on Center 540 RPM (Non Std. Rotation) | 12,995.00 | 8,836.60 |
| d) | C350-710PRO SFT Pro Package - CCW Rotation on Center 1000 RPM (Non Std. Rotation) | 12,995.00 | 8,836.60 |

~ ~ Selection 2 ~ Choose a Hitch Type and Accessories ~ ~

| | | | |
|-------------------------|---|----------|----------|
| 1) | C350-180 Trailing Hitch CV Style | 1,284.00 | 873.12 |
| Choose a Clevis: | | | |
| a) | C000-506WG Open Clevis (Minimum Requirement with a Flex Arm) | 541.00 | 367.88 |
| b) | C000-500WG Precision Hitch (Can be used with a Flex Arm) | 979.00 | 665.72 |
| c) | C000-513WG Solid tongue (Can be used with a Flex Arm) | 629.00 | 427.72 |
| d) | C000-515WG Clevis 2 3/16 " opening (Can be used with a Flex Arm) | 683.00 | 464.44 |
| e) | C000-510WG Pro Level Hitch (Can NOT be used with a Flex Arm) | 856.00 | 582.08 |
| Choose a Tractor Shaft: | | | |
| a) | 340-F501WG SFT Pro CV Shaft, 540 rpm | 4,740.00 | 3,223.20 |
| b) | 340-F401WG SFT Pro CV Shaft, 1000 rpm, 1-3/8" Shaft | 4,495.00 | 3,056.60 |
| 2) | C350-196 Equal Angle Hitch Kit w/ 540 RPM Shaft | 3,964.00 | 2,695.52 |

~ ~ Selection 3 ~ Choose Hydraulic Option ~ ~

| | | | |
|----|---|--------|--------|
| 1) | C350-805 Independent Double Acting Hose Kit OR | 474.00 | 322.32 |
| 2) | C350-810 Double Acting Hose Kit | 426.00 | 289.68 |

MASTER PRICE SHEET



Schulte Industries Ltd.

100 John Schulte Dr., Englefeld, SK. Canada, S0K 1N0

Tel: 306-287-3715 Fax: 306-287-3355 Toll Free: 1-800-404-6044

Web: www.Schulte.ca

Sourcewell - Road Right Of Way Maintenance Equipment

MACHINE PRICES AND SPECIFICATIONS

XH1500 Series 5 Rotary Cutter SFT Pro Drivelines



~ ~ Selection 4 ~ Choose a Blade Configuration ~ ~

| | | | | |
|----|----------|---|--------|--------|
| 1) | C350-450 | 2 Blade Pan Kit - cw Schulte Super Suction Updraft 4" Blades | 550.00 | 374.00 |
| 2) | C350-451 | 2 Blade Pan Kit - ccw Schulte Super Suction Updraft 4" Blades | 550.00 | 374.00 |
| 3) | C350-455 | 2 Blade Pan Kit - cw Schulte Super Suction Updraft 5" Blades | 650.00 | 442.00 |
| 4) | C350-456 | 2 Blade Pan Kit - ccw Schulte Super Suction Updraft 5" Blades | 650.00 | 442.00 |

~ ~ Selection 5 ~ Choose a Center Axle Kit ~ ~

| | | | | |
|----|----------|---|----------|----------|
| 1) | C350-820 | Walking (Axles Included) | 2,666.00 | 1,812.88 |
| 2) | C350-825 | Non Walking (4 Tire Kit, Axles Included) | 1,564.00 | 1,063.52 |
| 3) | C350-350 | Large Tire Option - Center Section (2 tires) | 4,364.00 | 2,967.52 |

C350-350 Includes mounts & tires - Only select tires for the wing axle option

~ ~ Selection 6 ~ Choose a Wing Axle Kit ~ ~

| | | | | |
|----|----------|---|----------|----------|
| 1) | C350-820 | Walking (Axles Included) | 2,666.00 | 1,812.88 |
| 2) | C350-830 | Non Walking (2 Tire Kit, Axles Included) | 1,104.00 | 750.72 |
| 3) | C350-825 | Non Walking (4 Tire Kit, Axles Included) | 1,564.00 | 1,063.52 |

~ ~ Selection 7 ~ Choose a Tire Option ~ ~

Please state the quantity of tires that you would like to order as the numbers listed below are just single tires and not a tire kit.

| | | | Retail Price/Tire | Contract Price/Tire |
|---|------------|---|-------------------|---------------------|
| 1) | 210-186WG | 27 X 10.5-15 Skid Steer Tire, LEFT | 588.00 | 399.84 |
| 2) | 210-187WG | 27 X 10.5-15 Skid Steer Tire, RIGHT | 588.00 | 399.84 |
| 3) | 210-186FWG | Foam Filled, 27 X 10.5-15 Skid Steer Tire, LEFT | 1,397.00 | 949.96 |
| 4) | 210-187FWG | Foam Filled, 27 X 10.5-15 Skid Steer Tire, RIGHT | 1,397.00 | 949.96 |
| NOTE: If choosing skid steer tires, be sure to choose correct amount of left & right tires | | | | |
| 5) | 210-182WG | Aircraft Tire (29 x 9-15/16 Ply) | 622.00 | 422.96 |
| 6) | 210-182FWG | Foam Filled Aircraft Tire (29 x 9-15/16 Ply) | 1,102.00 | 749.36 |
| 7) | 210-192WG | Solid Laminated Tire, 6 x 9 x 26 | 609.00 | 414.12 |

~ ~ Selection 8 ~ Choose a Destination Package ~ ~

Please select the destination of the cutter for proper Decals, Manuals, and Shielding

| | | | | |
|----|---------|--|-------|-------|
| 1) | C350-NA | North American/ Australia Destination Kits | 84.00 | 57.12 |
|----|---------|--|-------|-------|

MASTER PRICE SHEET



Schulte Industries Ltd.

100 John Schulte Dr., Englefeld, SK. Canada, S0K 1N0

Tel: 306-287-3715 Fax: 306-287-3355 Toll Free: 1-800-404-6044

Web: www.Schulte.ca

Sourcewell - Road Right Of Way Maintenance Equipment

MACHINE PRICES AND SPECIFICATIONS

XH1500 Series 5 Rotary Cutter

SFT Pro Drivelines



~ ~ Selection 9 ~ Extra Options ~ ~

| | | | | |
|------------------------|----------|----------------------------|-----------------|---------------|
| 1) | C350-540 | Rear Half Belting Kit | 956.00 | 650.08 |
| 2) | C308-890 | Tire Bumper Kit | 1,066.00 | 724.88 |
| 3) | C350-880 | Right Hand Gauge Wheel Kit | 1,026.00 | 697.68 |
| 4) | C350-885 | Left Hand Gauge Wheel Kit | 1,026.00 | 697.68 |
| 5) | C306-305 | Flex Arm Mount | 244.00 | 165.92 |
| 6) | C000-620 | Toolbox Mount & Toolbox | 1,466.00 | 996.88 |
| Assembly Charge | | | Net | 400.00 |

OPTIONAL PDI INCLUDES: greasing of all pivot points, gearbox oil checked, charge hydraulic cylinders and install pioneer ends. Tires will be installed where necessary. It is the dealers responsibility to remove shipping brackets & banding as well as to adjust mower height as specified in the operators manual. Please go to the Schulte website/dealer access for further information.

PREDELIVERY SERVICE IS REQUIRED BY DEALER OR END USER



MASTER PRICE SHEET



Schulte Industries Ltd.

100 John Schulte Dr., Englefeld, SK. Canada, S0K 1N0

Tel: 306-287-3715 Fax: 306-287-3355 Toll Free: 1-800-404-6044

Web: www.Schulte.ca

Sourcewell - Road Right Of Way Maintenance Equipment

MACHINE PRICES AND SPECIFICATIONS

Cutter Command System



CUTTER COMMAND SYSTEM FEATURES

- Speed sensors measure RPM to detect slipping and alert the operator
- Temperature sensors measure the gearboxes oil temperature
- Minimizes the risk of premature gearbox failures
- System logs the total working hours of the cutter
- System provides service reminders at the appropriate time intervals
- Helps prevent clutch overheating
- Helps reduce downtime and repair costs
- Streamlines billing and improves operations

~ ~ XH1500 Series 5 Cutter Command System ~ ~

| | | <i>Retail Price</i> | <i>Contract Price</i> |
|----|---|---------------------|-----------------------|
| 1) | C350-910 XH1500 1000RPM Monitor System - Customer Installed | 9,650.00 | 6,562.00 |
| 2) | C350-915 XH1500 1000RPM Monitor System - Factory Installed | 10,800.00 | 7,344.00 |
| 3) | C350-930 XH1500 540RPM Monitor System - Customer Installed | 9,650.00 | 6,562.00 |
| 4) | C350-935 XH1500 540RPM Monitor System - Factory Installed | 10,800.00 | 7,344.00 |

~ ~ XH1000 Series 5 Cutter Command System ~ ~

| | | | |
|----|---|----------|----------|
| 1) | C350-920 XH1000 1000RPM Monitor System - Customer Installed | 9,050.00 | 6,154.00 |
| 2) | C350-925 XH1000 1000RPM Monitor System - Factory Installed | 9,795.00 | 6,660.60 |
| 3) | C350-940 XH1000 540RPM Monitor System - Customer Installed | 9,050.00 | 6,154.00 |
| 4) | C350-945 XH1000 540RPM Monitor System - Factory Installed | 9,795.00 | 6,660.60 |



MASTER PRICE SHEET



Schulte Industries Ltd.

100 John Schulte Dr., Englefeld, SK. Canada, S0K 1N0

Tel: 306-287-3715 Fax: 306-287-3355 Toll Free: 1-800-404-6044

Web: www.Schulte.ca

Sourcewell - Road Right Of Way Maintenance Equipment

MACHINE PRICES AND SPECIFICATIONS

XH1000 Series 5 Rotary Cutter



CUTTER FEATURES

- 7GA deck
- Replaceable skid shoes
- Double safety chains front & rear
- Hydraulic phasing lift system
- Hydraulic wing lift system
- 517 Hubs and axles
- Single domed, sweep clean deck
- Rubber suspension - standard
- Four gearbox drive layout
240hp down, 275hp splitter
- Full floating front hitch
- Deck protection rings
- S000-010 safety chain kit 1/4" grade 70 with 10,000 lbs capacity
- 1/4" Round skid pans (Stump Jumpers)
- Pentagon blade bolt design
- Operator's manual in holder

~ ~ Selection 1 ~ Choose a Basic Unit and Drive Package ~ ~

| | | Retail Price | Contract Price |
|-------------------------|--|--------------|----------------|
| 1) | C350-100 Basic Unit XH Series 5 | 27,022.00 | 18,374.96 |
| 2) | C350-250 10' Option (Required) | 18,652.00 | 12,683.36 |
| 3) | S000-165 Safety Light Kit (Required) | 839.00 | 570.52 |
| 4) | C302-830 ISO Couplers (Required) | 70.00 | 47.60 |
| Choose a Drive Package: | | | |
| a) | C350-745 CW Rotation on Center, 540 RPM, (Std. Rotation) | 6,220.00 | 4,229.60 |
| b) | C350-755 CW Rotation on Center, 1000 RPM (Std. Rotation) | 6,220.00 | 4,229.60 |

~ ~ Selection 2 ~ Choose a Hitch Type and Accessories ~ ~

| | | | |
|-------------------------|---|----------|----------|
| 1) | C350-180 Trailing Hitch CV Style | 1,284.00 | 873.12 |
| Choose a Clevis: | | | |
| a) | C000-506WG Open Clevis (Minimum Requirement with a Flex Arm) | 541.00 | 367.88 |
| b) | C000-500WG Precision Hitch (Can be used with a Flex Arm) | 979.00 | 665.72 |
| c) | C000-513WG Solid tongue (Can be used with a Flex Arm) | 629.00 | 427.72 |
| d) | C000-515WG Clevis 2 3/16 " opening (Can be used with a Flex Arm) | 683.00 | 464.44 |
| e) | C000-510WG Pro Level Hitch (Can <u>NOT</u> be used with a Flex Arm) | 856.00 | 582.08 |
| Choose a Tractor Shaft: | | | |
| a) | 340-870WG CV Shaft, 540 rpm | 2,234.00 | 1,519.12 |
| b) | 340-648WG CV Shaft, 1000 rpm | 1,850.00 | 1,258.00 |
| c) | 340-658WG CV Shaft 1000 RPM 1 3/4" shaft | 2,437.00 | 1,657.16 |
| 2) | C350-196 Equal Angle Hitch Kit w/ 540 RPM Shaft | 3,964.00 | 2,695.52 |

~ ~ Selection 3 ~ Choose Hydraulic Option ~ ~

| | | | |
|----|---|--------|--------|
| 1) | C350-815 Independent Double Acting Hose Kit Required | 243.00 | 165.24 |
|----|---|--------|--------|

MASTER PRICE SHEET



Schulte Industries Ltd.

100 John Schulte Dr., Englefeld, SK. Canada, S0K 1N0

Tel: 306-287-3715 Fax: 306-287-3355 Toll Free: 1-800-404-6044

Web: www.Schulte.ca

Sourcewell - Road Right Of Way Maintenance Equipment

MACHINE PRICES AND SPECIFICATIONS

XH1000 Series 5 Rotary Cutter



~ ~ Selection 4 ~ Choose a Blade Configuration ~ ~

| | | | | |
|----|----------|--|--------|--------|
| 1) | C350-470 | 2 Blade Pan kit - CW Schulte Super Suction Updraft 4" Blades | 375.00 | 255.00 |
| 2) | C350-475 | 2 Blade Pan kit - CW Schulte Super Suction Updraft 5" Blades | 447.00 | 303.96 |

~ ~ Selection 5 ~ Choose a Center Axle Kit ~ ~

| | | | | |
|----|----------|---|----------|----------|
| 1) | C350-820 | Walking Axle <i>(Axles Included)</i> | 2,666.00 | 1,812.88 |
| 2) | C350-825 | Non Walking <i>(4 Tire Kit, Axles Included)</i> | 1,564.00 | 1,063.52 |
| 3) | C350-350 | Large Tire Option - Center Section <i>(2 tires)</i> | 4,364.00 | 2,967.52 |

C350-350 Includes mounts & tires - Only select tires for the wing axle option

~ ~ Selection 6 ~ Choose a Wing Axle Kit ~ ~

| | | | | |
|----|----------|---|----------|--------|
| 1) | C350-835 | Walking Axle <i>(Axle Included)</i> | 1,326.00 | 901.68 |
| 2) | C350-840 | Non Walking <i>(1 Tire Kit, Axle Included)</i> | 553.00 | 376.04 |
| 3) | C350-845 | Non Walking <i>(2 Tire Kit, Axles Included)</i> | 782.00 | 531.76 |

~ ~ Selection 7 ~ Choose a Tire Option ~ ~

Please state the quantity of tires that you would like to order as the numbers listed below are just single tires and not a tire kit.

| | | | Retail Price/Tire | Contract Price/Tire |
|---|------------|---|-------------------|---------------------|
| 1) | 210-186WG | 27 X 10.5-15 Skid Steer Tire, LEFT | 588.00 | 399.84 |
| 2) | 210-187WG | 27 X 10.5-15 Skid Steer Tire, RIGHT | 588.00 | 399.84 |
| 3) | 210-186FWG | Foam Filled, 27 X 10.5-15 Skid Steer Tire, LEFT | 1,397.00 | 949.96 |
| 4) | 210-187FWG | Foam Filled, 27 X 10.5-15 Skid Steer Tire, RIGHT | 1,397.00 | 949.96 |
| NOTE: If choosing skid steer tires, be sure to choose correct amount of left & right tires | | | | |
| 5) | 210-182WG | Aircraft Tire (29 x 9-15/16 Ply) | 622.00 | 422.96 |
| 6) | 210-182FWG | Foam Filled Aircraft Tire (29 x 9-15/16 Ply) | 1,102.00 | 749.36 |
| 7) | 210-192WG | Solid Laminated Tire, 6 x 9 x 26 | 609.00 | 414.12 |

~ ~ Selection 8 ~ Choose a Destination Package ~ ~

Please select the destination of the cutter for proper Decals, Manuals, and Shielding

| | | | | |
|----|---------|--|-------|-------|
| 1) | C350-NA | North American/ Australia Destination Kits | 84.00 | 57.12 |
|----|---------|--|-------|-------|

MASTER PRICE SHEET



Schulte Industries Ltd.

100 John Schulte Dr., Englefeld, SK. Canada, S0K 1N0

Tel: 306-287-3715 Fax: 306-287-3355 Toll Free: 1-800-404-6044

Web: www.Schulte.ca

Sourcewell - Road Right Of Way Maintenance Equipment

MACHINE PRICES AND SPECIFICATIONS

XH1000 Series 5 Rotary Cutter



~ ~ Selection 9 ~ Extra Options ~ ~

| | | | | |
|------------------------|----------|---------------------------------|-----------------|---------------|
| 1) | C350-550 | XH1000 S5 Rear Half Belting Kit | 704.00 | 478.72 |
| 2) | C350-880 | Right Hand Gauge Wheel Kit | 1,026.00 | 697.68 |
| 3) | C306-305 | Flex Arm Mount | 244.00 | 165.92 |
| 4) | C000-620 | Toolbox Mount & Toolbox | 1,466.00 | 996.88 |
| Assembly Charge | | | Net | 300.00 |

OPTIONAL PDI INCLUDES: greasing of all pivot points, gearbox oil checked, charge hydraulic cylinders and install pioneer ends. Tires will be installed where necessary. It is the dealers responsibility to remove shipping brackets & banding as well as to adjust mower height as specified in the operators manual. Please go to the Schulte website/dealer access for further information.

PREDELIVERY SERVICE IS REQUIRED BY DEALER OR END USER



MASTER PRICE SHEET



Schulte Industries Ltd.

100 John Schulte Dr., Englefeld, SK. Canada, S0K 1N0

Tel: 306-287-3715 Fax: 306-287-3355 Toll Free: 1-800-404-6044

Web: www.Schulte.ca

Sourcewell - Road Right Of Way Maintenance Equipment

MACHINE PRICES AND SPECIFICATIONS

FX-1800 Rotary Cutter (Pan Unit)



CUTTER FEATURES

- 540/1000 RPM Drive
- 7 ga. Spun Formed Stump Jumpers
- Replaceable Skid Shoes
- 7 ga Single Domed Deck
10000lbs cap.)
- Deck Protection Rings
- Over Center Folding Wings
- 80 Degree CV Drive
- Height Control Cylinder & Hoses
- Wing Lift Cylinders & Hoses
- S000-010 Safety Chain (1/4" gr.70 -
- Operator's and Parts Manual Holder
- Cutting Width 180" (4.57m)

~ ~ Selection 1 ~ Choose a Basic Unit, Drive Package ~ ~

| | | Retail Price | Contract Price |
|-------------------------|---|--------------|----------------|
| C185-100 | Schulte FX-1800, Basic Unit | 24,774.00 | 16,846.32 |
| S000-085 | Safety Light Kit (Required) | 814.00 | 553.52 |
| Choose a Drive Package: | | | |
| a) | C306-705 Drive Package, CW Center, 540 RPM | 8,765.00 | 5,960.20 |
| b) | C306-715 Drive Package, CW Center, 1000 RPM | 8,765.00 | 5,960.20 |

~ ~ Selection 2 ~ Choose a Hitch Option ~ ~

| | | | |
|--------------------|--|----------|----------|
| C185-180 | Trailing Hitch, CV Style | 1,219.00 | 828.92 |
| Choose a CV Shaft: | | | |
| a) | 340-870WG CV Shaft, 540 RPM | 2,234.00 | 1,519.12 |
| b) | 340-648WG CV Shaft, 1000 RPM | 1,850.00 | 1,258.00 |
| c) | 340-658WG CV Shaft 1000 RPM 1 3/4" shaft | 2,437.00 | 1,657.16 |
| C185-196 | Equal Angle Hitch Kit w/ 540 RPM Shaft | 3,966.00 | 2,696.88 |

~ ~ Selection 3 ~ Choose a Clevis ~ ~

| | | | |
|------------|-----------------------------------|--------|--------|
| C000-506WG | Open Clevis (Minimum Requirments) | 541.00 | 367.88 |
| C000-500WG | Precision hitch | 979.00 | 665.72 |
| C000-513WG | Solid Tongue | 629.00 | 427.72 |
| C000-510WG | Pro Level Hitch | 856.00 | 582.08 |

~ ~ Selection 4 ~ Choose a Center Axle Mount Style ~ ~

| | | | |
|----------|--|----------|----------|
| C185-820 | Walking (Axles Included) | 3,382.00 | 2,299.76 |
| C185-830 | Non Walking (2 Tire Kit, Axles Included) | 1,205.00 | 819.40 |
| C185-825 | Non Walking (4 Tire Kit, Axles Included) | 1,869.00 | 1,270.92 |

MASTER PRICE SHEET



Schulte Industries Ltd.

100 John Schulte Dr., Englefeld, SK. Canada, S0K 1N0

Tel: 306-287-3715 Fax: 306-287-3355 Toll Free: 1-800-404-6044

Web: www.Schulte.ca

Sourcewell - Road Right Of Way Maintenance Equipment

MACHINE PRICES AND SPECIFICATIONS

FX-1800 Rotary Cutter (Pan Unit)



~ ~ Selection 5 ~ Choose a Wing Axle Mount Style ~ ~

| | | | |
|----------|---|----------|----------|
| C185-820 | Walking <i>(Axles Included)</i> | 3,382.00 | 2,299.76 |
| C185-830 | Non Walking <i>(2 Tire Kit, Axles Included)</i> | 1,205.00 | 819.40 |
| C185-825 | Non Walking <i>(4 Tire Kit, Axles Included)</i> | 1,869.00 | 1,270.92 |

~ ~ Selection 6 ~ Choose a Safety Guard ~ ~

| | | | |
|----------|------------------------------------|----------|----------|
| C180-520 | Chain Guards Single Front and Rear | 1,644.00 | 1,117.92 |
| C180-500 | Chain Guards Double Front and Rear | 2,098.00 | 1,426.64 |

~ ~ Selection 7 ~ Choose a Pan Kit ~ ~

| | | | |
|----------|--------------------|----------|----------|
| C316-450 | Pan Kit (required) | 2,670.00 | 1,815.60 |
|----------|--------------------|----------|----------|

~ ~ Selection 8 ~ Choose a Blade Configuration ~ ~

| | | | | |
|----------|--|----|----------|--------|
| C316-451 | CW Schulte Super Suction Updraft 4" Blades | Or | 777.00 | 528.36 |
| C316-459 | CW Schulte Super Suction Updraft 5" Blades | | 1,006.00 | 684.08 |

~ ~ Selection 9 ~ Choose a Tire Option ~ ~

Please state the quantity of tires that you would like to order as the numbers listed below are single tires and not tire kits.

| | | Retail Price/Tire | Contract Price/Tire |
|------------|---|-------------------|---------------------|
| 210-003WG | Solid Laminated Tires, 6 x 9 x 20 | 380.00 | 258.40 |
| 210-175WG | Forklift Tire 6.5 x 10 - 12 ply on 2 pce 5 bolt rim | 533.00 | 362.44 |
| 210-175FWG | Foam Filled Forklift Tire 6.5 x 10 - 12 ply on 2 pce 5 bolt rim | 924.00 | 628.32 |
| 210-540WG | Tire 24x8-14 20 Ply Rated Severe Duty | 622.00 | 422.96 |
| 210-540FWG | Tire 24x8-14 20 Ply Rated Severe Duty Foam Filled | 981.00 | 667.08 |
| 210-192WG | Solid Laminated Tire, 6 x 9 x 26 | 609.00 | 414.12 |

~ ~ Selection 10 ~ Choose a Destination Code ~ ~

| | | | |
|---------|---------------------------------------|-------|-------|
| C185-NA | North American & Australian Decal Kit | 84.00 | 57.12 |
|---------|---------------------------------------|-------|-------|

MASTER PRICE SHEET



Schulte Industries Ltd.

100 John Schulte Dr., Englefeld, SK. Canada, S0K 1N0

Tel: 306-287-3715 Fax: 306-287-3355 Toll Free: 1-800-404-6044

Web: www.Schulte.ca

Sourcewell - Road Right Of Way Maintenance Equipment

MACHINE PRICES AND SPECIFICATIONS

FX-1800 Rotary Cutter (Pan Unit)



~ ~ Selection 11 ~ Choose Extra Options ~ ~

| | | | |
|----------|--|-----------------|---------------|
| C185-304 | Strut Mount for Flex Arm,(Factory Installed) | 1,040.00 | 707.20 |
| C185-305 | Strut Mount for Flex Arm, (parts only) | 436.00 | 296.48 |
| C185-325 | Tension Link Leveling Rod , Factory Installed | 368.00 | 250.24 |
| C185-330 | Tension Link Leveling Rod , Weld on Parts only | 459.00 | 312.12 |
| C185-310 | Hose Kit, independent wing-lift | 276.00 | 187.68 |
| | Assembly Charge on Pan Units | Net | 400.00 |

IMPORTANT:

- 1) Safety Chain Kit must be used at all times when moving equipment on any type of road.
- 2) OSHA, ASAE, SAE, and ANSI standards REQUIRE the use of Chain Guards, Deflectors, or Solid Skirts/Bands at all times. Schulte recommends mower be equipped with deflectors or double chain guards for all mowing purposes. Single chain guards may be used for agricultural purposes only and are specifically not recommended for highway, right-of-way, parks or greenbelt mowing. Before ordering a mower, read the Thrown Object Shield Message in the Rotary Cutter Spec section in sales price book.



MASTER PRICE SHEET



Schulte Industries Ltd.

100 John Schulte Dr., Englefeld, SK. Canada, S0K 1N0

Tel: 306-287-3715 Fax: 306-287-3355 Toll Free: 1-800-404-6044

Web: www.Schulte.ca

Sourcewell - Road Right Of Way Maintenance Equipment
MACHINE PRICES AND SPECIFICATIONS

FX-1800C Rotary Cutter (DOT Configuration Options)



CUTTER FEATURES

- 540/1000 RPM Drive
- 7 ga. Spun Formed Stump Jumpers
- Replaceable Skid Shoes
- 7 ga Single Domed Deck
- Deck Protection Rings
- Over Center Folding Wings
- Transport Width (max with duals on wings) 102"(2.59m)
- 80 Degree CV Drive
- Height Control Cylinder & Hoses
- Wing Lift Cylinders & Hoses
- S000-010 Safety Chain (1/4" gr.70 - 10000lbs cap.)
- Operator's and Parts Manual Holder
- Cutting Width 180" (4.57m)
- Complete with replaceable side bands & hydraulic phasing system

~ ~ Selection 1 ~ Choose a Basic Unit, Drive Package ~ ~

| | | Retail Price | Contract Price |
|-------------------------|--|--------------|----------------|
| C186-100 | Schulte FX-1800C, Basic Unit <i>c/w replaceable side bands & hydraulic phasing system</i> | 27,800.00 | 18,904.00 |
| S000-085 | Safety Light Kit (Required) | 814.00 | 553.52 |
| Choose a Drive Package: | | | |
| a) | C306-705 Drive Package, CW Center, 540 RPM | 8,765.00 | 5,960.20 |
| b) | C306-715 Drive Package, CW Center, 1000 RPM | 8,765.00 | 5,960.20 |

~ ~ Selection 2 ~ Choose a Hitch Option ~ ~

| | | | |
|--------------------|--|----------|----------|
| C185-180 | Trailing Hitch, CV Style | 1,219.00 | 828.92 |
| Choose a CV Shaft: | | | |
| a) | 340-870WG CV Shaft, 540 RPM | 2,234.00 | 1,519.12 |
| b) | 340-648WG CV Shaft, 1000 RPM | 1,850.00 | 1,258.00 |
| c) | 340-658WG CV Shaft 1000 RPM 1 3/4" shaft | 2,437.00 | 1,657.16 |
| C185-196 | Equal Angle Hitch Kit w/ 540 RPM Shaft | 3,966.00 | 2,696.88 |

~ ~ Selection 3 ~ Choose a Clevis ~ ~

| | | | |
|------------|------------------------------------|--------|--------|
| C000-506WG | Open Clevis (Minimum Requirements) | 541.00 | 367.88 |
| C000-500WG | Precision hitch | 979.00 | 665.72 |
| C000-513WG | Solid Tongue | 629.00 | 427.72 |
| C000-510WG | Pro Level Hitch | 856.00 | 582.08 |

~ ~ Selection 4 ~ Choose a Center Axle Mount Style ~ ~

| | | | |
|----------|---|----------|----------|
| C185-820 | Walking (Axles Included) | 3,382.00 | 2,299.76 |
| C185-830 | Non Walking (2 Tire Kit, Axles Included) | 1,205.00 | 819.40 |
| C185-825 | Non Walking (4 Tire Kit, Axles Included) | 1,869.00 | 1,270.92 |
| C186-880 | Wheel Mounts For Large Tires (Includes hubs/spindles & Tires) | 4,695.00 | 3,192.60 |

If choosing the C186-880, you MUST choose the C185-830 wing axle mount and two tires

MASTER PRICE SHEET



Schulte Industries Ltd.

100 John Schulte Dr., Englefeld, SK. Canada, S0K 1N0
 Tel: 306-287-3715 Fax: 306-287-3355 Toll Free: 1-800-404-6044
 Web: www.Schulte.ca

Sourcewell - Road Right Of Way Maintenance Equipment

MACHINE PRICES AND SPECIFICATIONS

FX-1800C Rotary Cutter (DOT Configuration Options)



~ ~ Selection 5 ~ Choose a Wing Axle Mount Style ~ ~

| | | | |
|----------|---|----------|----------|
| C185-820 | Walking <i>(Axles Included)</i> | 3,382.00 | 2,299.76 |
| C185-830 | Non Walking <i>(2 Tire Kit, Axles Included)</i> | 1,205.00 | 819.40 |
| C185-825 | Non Walking <i>(4 Tire Kit, Axles Included)</i> | 1,869.00 | 1,270.92 |

~ ~ Selection 6 ~ Choose a Safety Guard ~ ~

| | | | |
|----------|------------------------------------|----------|----------|
| C180-520 | Chain Guards Single Front and Rear | 1,644.00 | 1,117.92 |
| C180-500 | Chain Guards Double Front and Rear | 2,098.00 | 1,426.64 |

~ ~ Selection 7 ~ Choose a Pan Kit ~ ~

| | | | |
|----------|--------------------|----------|----------|
| C316-450 | Pan Kit (required) | 2,670.00 | 1,815.60 |
|----------|--------------------|----------|----------|

~ ~ Selection 8 ~ Choose a Blade Configuration ~ ~

| | | | | |
|----------|--|----|----------|--------|
| C316-451 | CW Schulte Super Suction Updraft 4" Blades | Or | 777.00 | 528.36 |
| C316-459 | CW Schulte Super Suction Updraft 5" Blades | | 1,006.00 | 684.08 |

~ ~ Selection 9 ~ Choose a Tire Option ~ ~

Please state the quantity of tires that you would like to order as the numbers listed below are single tires and not tire kits.

| | | Retail Price/Tire | Contract Price/Tire |
|------------|---|-------------------|---------------------|
| 210-003WG | Solid Laminated Tires, 6 x 9 x 20 | 380.00 | 258.40 |
| 210-175WG | Forklift Tire 6.5 x 10 - 12 ply on 2 pce 5 bolt rim | 533.00 | 362.44 |
| 210-175FWG | Foam Filled Forklift Tire 6.5 x 10 - 12 ply on 2 pce 5 bolt rim | 924.00 | 628.32 |
| 210-540WG | Tire 24x8-14 20 Ply Rated Severe Duty | 622.00 | 422.96 |
| 210-540FWG | Tire 24x8-14 20 Ply Rated Severe Duty Foam Filled | 981.00 | 667.08 |
| 210-192WG | Solid Laminated Tire, 6 x 9 x 26 | 609.00 | 414.12 |

~ ~ Selection 10 ~ Choose a Destination Code ~ ~

| | | | |
|---------|---------------------------------------|-------|-------|
| C185-NA | North American & Australian Decal Kit | 84.00 | 57.12 |
|---------|---------------------------------------|-------|-------|

MASTER PRICE SHEET



Schulte Industries Ltd.

100 John Schulte Dr., Englefeld, SK. Canada, S0K 1N0

Tel: 306-287-3715 Fax: 306-287-3355 Toll Free: 1-800-404-6044

Web: www.Schulte.ca

Sourcewell - Road Right Of Way Maintenance Equipment

MACHINE PRICES AND SPECIFICATIONS

FX-1800C Rotary Cutter (DOT Configuration Options)



~ ~ Selection 11 ~ Choose Extra Options ~ ~

| | | | |
|----------|--|-----------------|---------------|
| C185-304 | Strut Mount for Flex Arm,(Factory Installed) | 1,040.00 | 707.20 |
| C185-305 | Strut Mount for Flex Arm, (parts only) | 436.00 | 296.48 |
| C185-325 | Tension Link Leveling Rod , Factory Installed | 368.00 | 250.24 |
| C185-330 | Tension Link Leveling Rod , Weld on Parts only | 459.00 | 312.12 |
| C185-310 | Hose Kit, independent wing-lift | 276.00 | 187.68 |
| C000-620 | Toolbox Mount & Toolbox | 1,466.00 | 996.88 |
| | Assembly Charge on Pan Units | Net | 400.00 |

IMPORTANT:

- 1) Safety Chain Kit must be used at all times when moving equipment on any type of road.
- 2) OSHA, ASAE, SAE, and ANSI standards REQUIRE the use of Chain Guards, Deflectors, or Solid Skirts/Bands at all times. Schulte recommends mower be equipped with deflectors or double chain guards for all mowing purposes. Single chain guards may be used for agricultural purposes only and are specifically not recommended for highway, right-of-way, parks or greenbelt mowing. Before ordering a mower, read the Thrown Object Shield Message in the Rotary Cutter Spec section in sales price book.



MASTER PRICE SHEET



Schulte Industries Ltd.

100 John Schulte Dr., Englefeld, SK. Canada, S0K 1N0

Tel: 306-287-3715 Fax: 306-287-3355 Toll Free: 1-800-404-6044

Web: www.Schulte.ca

Sourcewell - Road Right Of Way Maintenance Equipment

MACHINE PRICES AND SPECIFICATIONS

FX-1200 Rotary Cutter (Pan Unit)



CUTTER FEATURES

- 540/1000 RPM Drive
- 7 ga. Spun Formed Stump Jumpers
- Replaceable Skid Shoes
- 7 ga Single Domed Deck
- Deck Protection Rings
- Over Center Folding Wings
- Transport Width (max with duals on wings) 97.5" (2.47m)
- 80 Degree CV Drive
- Height Control Cylinder & Hoses
- Wing Lift Cylinders & Hoses
- S000-010 Safety Chain (1/4" gr.70 - 10000lbs cap.)
- Operator's and Parts Manual Holder
- Cutting Width 126" (3.20m)

more specs on brochure

~ ~ Selection 1 ~ Choose a Basic Unit, Drive Package ~ ~

| | | Retail Price | Contract Price |
|-----------------------------------|---------------------------------|--------------|----------------|
| C195-100 | FX1200, Basic Unit | 24,750.00 | 16,830.00 |
| S000-085 | Safety Light Kit (Required) | 814.00 | 553.52 |
| <i>DRIVE PACKAGE (choose one)</i> | | | |
| C307-700 | CW Rotation on Center, 540 RPM | 6,430.00 | 4,372.40 |
| C307-710 | CW Rotation on Center, 1000 RPM | 6,430.00 | 4,372.40 |

~ ~ Selection 2 ~ Choose a Hitch Option ~ ~

| | | | |
|--------------------|--|----------|----------|
| C185-180 | Trailing Hitch, CV Style | 1,219.00 | 828.92 |
| Choose a CV Shaft: | | | |
| a) 340-870WG | CV Shaft, 540 RPM | 2,234.00 | 1,519.12 |
| b) 340-648WG | CV Shaft, 1000 RPM | 1,850.00 | 1,258.00 |
| C185-196 | Equal Angle Hitch Kit w/ 540 RPM Shaft | 3,966.00 | 2,696.88 |

~ ~ Selection 3 ~ Choose a Clevis ~ ~

| | | | |
|------------|-----------------------------------|--------|--------|
| C000-506WG | Open Clevis (Minimum Requirments) | 541.00 | 367.88 |
| C000-500WG | Precision hitch | 979.00 | 665.72 |
| C000-513WG | Solid Tongue | 629.00 | 427.72 |
| C000-510WG | Pro Level Hitch | 856.00 | 582.08 |

~ ~ Selection 4 ~ Choose a Center Axle Mount Style ~ ~

| | | | |
|----------|--|----------|----------|
| C185-820 | Walking (Axles Included) | 3,382.00 | 2,299.76 |
| C185-830 | Non Walking (2 Tire Kit, Axles Included) | 1,205.00 | 819.40 |
| C185-825 | Non Walking (4 Tire Kit, Axles Included) | 1,869.00 | 1,270.92 |

MASTER PRICE SHEET



Schulte Industries Ltd.

100 John Schulte Dr., Englefeld, SK. Canada, S0K 1N0

Tel: 306-287-3715 Fax: 306-287-3355 Toll Free: 1-800-404-6044

Web: www.Schulte.ca

Sourcewell - Road Right Of Way Maintenance Equipment

MACHINE PRICES AND SPECIFICATIONS

FX-1200 Rotary Cutter (Pan Unit)



~ ~ Selection 5 ~ Choose a Wing Axle Mount Style ~ ~

| | | | |
|----------|---|----------|----------|
| C185-835 | Walking Axle <i>(Axle Included)</i> | 1,654.00 | 1,124.72 |
| C185-840 | Non Walking <i>(1 Tire Kit, Axle Included)</i> | 646.00 | 439.28 |
| C185-845 | Non Walking <i>(2 Tire Kit, Axles Included)</i> | 854.00 | 580.72 |

~ ~ Selection 6 ~ Choose a Safety Guard ~ ~

| | | | |
|----------|----------------------------------|----------|--------|
| C190-520 | Chain Guards Single Front & Rear | 1,131.00 | 769.08 |
| C190-500 | Chain Guards Double Front & Rear | 1,452.00 | 987.36 |

~ ~ Selection 7 ~ Choose The Pan Kit ~ ~

| | | | |
|----------|--------------------|----------|----------|
| C317-450 | Pan Kit (required) | 1,780.00 | 1,210.40 |
|----------|--------------------|----------|----------|

~ ~ Selection 8 ~ Choose a Blade Configuration ~ ~

| | | | |
|----------|---------------------------|--------|--------|
| C317-451 | Updraft Blades, CW Center | 523.00 | 355.64 |
|----------|---------------------------|--------|--------|

~ ~ Selection 9 ~ Choose a Tire Option ~ ~

Please state the quantity of tires that you would like to order as the numbers listed below are single tires and not tire kits.

| | | Retail Price/Tire | Contract Price/Tire |
|------------|---|-------------------|---------------------|
| 210-003WG | Solid Laminated Tires, 6 x 9 x 20 | 380.00 | 258.40 |
| 210-175WG | Tire Assy, Forklift, 6.5 x 10 - 12 ply on 2 pce 5 bolt rim | 533.00 | 362.44 |
| 210-175FWG | Foam Filled Forklift Tire 6.5 x 10 - 12 ply on 2 pce 5 bolt rim | 924.00 | 628.32 |
| 210-540WG | Tire 24x8-14 20 Ply Rated Severe Duty | 622.00 | 422.96 |
| 210-540FWG | Tire 24x8-14 20 Ply Rated Severe Duty Foam Filled | 981.00 | 667.08 |
| 210-192WG | Solid Laminated Tire, 6 x 9 x 26 | 609.00 | 414.12 |

~ ~ Selection 10 ~ Choose a Destination Code ~ ~

| | | | |
|---------|---------------------------------------|-------|-------|
| C195-NA | North American & Australian Decal Kit | 71.00 | 48.28 |
|---------|---------------------------------------|-------|-------|

MASTER PRICE SHEET



Schulte Industries Ltd.

100 John Schulte Dr., Englefeld, SK. Canada, S0K 1N0

Tel: 306-287-3715 Fax: 306-287-3355 Toll Free: 1-800-404-6044

Web: www.Schulte.ca

Sourcewell - Road Right Of Way Maintenance Equipment

MACHINE PRICES AND SPECIFICATIONS

FX-1200 Rotary Cutter (Pan Unit)



~ ~ Selection 11 ~ Choose a Extra Options ~ ~

| | | | |
|------------------------|--|-----------------|---------------|
| C185-304 | Strut Mount for Flex Arm,(Factory Installed) | 1,040.00 | 707.20 |
| C185-305 | Strut Mount for Flex Arm, (parts only) | 436.00 | 296.48 |
| C185-325 | Tension Link Leveling Rod , Factory Installed | 368.00 | 250.24 |
| C185-330 | Tension Link Leveling Rod , Weld on Parts only | 459.00 | 312.12 |
| Assembly Charge | | Net | 300.00 |

IMPORTANT:

- 2) OSHA, ASAE, SAE, and ANSI standards REQUIRE the use of Chain Guards, Deflectors, or Solid Skirts/Bands at all times. Schulte recommends mower be equipped with deflectors or double chain guards for all mowing purposes. Single chain guards may be used for agricultural purposes only and are specifically not recommended for highway, right-of-way, parks or greenbelt mowing. Before ordering a mower, read the Thrown Object Shield Message in the Rotary Cutter Spec section in sales price book.



MASTER PRICE SHEET



Schulte Industries Ltd.

100 John Schulte Dr., Englefeld, SK. Canada, S0K 1N0

Tel: 306-287-3715 Fax: 306-287-3355 Toll Free: 1-800-404-6044

Web: www.Schulte.ca

Sourcewell - Road Right Of Way Maintenance Equipment

MACHINE PRICES AND SPECIFICATIONS

FX-1200C Rotary Cutter (DOT Configuration Options)



CUTTER FEATURES

- 540/1000 RPM Drive
- 7 ga. Spun Formed Stump Jumpers
- Replaceable Skid Shoes
- 7 ga Single Domed Deck
- Deck Protection Rings
- Over Center Folding Wings
- Transport Width (max with duals on wings) 97.5" (2.47m)
- Complete with replaceable side bands & hydraulic phasing system
- 80 Degree CV Drive
- Height Control Cylinder & Hoses
- Wing Lift Cylinders & Hoses
- S000-010 Safety Chain (1/4" gr.70 - 10000lbs cap.)
- Operator's and Parts Manual Holder
- Cutting Width 126" (3.20m)

~ ~ Selection 1 ~ Choose a Basic Unit, Drive Package ~ ~

| | | Retail Price | Contract Price |
|-----------------------------------|---|--------------|----------------|
| C187-100 | FX1200C, Basic Unit <i>c/w replaceable side bands & hydraulic phasing system</i> | 26,269.00 | 17,862.92 |
| S000-085 | Safety Light Kit (Required) | 814.00 | 553.52 |
| DRIVE PACKAGE (choose one) | | | |
| C307-700 | CW Rotation on Center, 540 RPM | 6,430.00 | 4,372.40 |
| C307-710 | CW Rotation on Center, 1000 RPM | 6,430.00 | 4,372.40 |

~ ~ Selection 2 ~ Choose a Hitch Option ~ ~

| | | | |
|--------------------|--|----------|----------|
| C185-180 | Trailing Hitch, CV Style | 1,219.00 | 828.92 |
| Choose a CV Shaft: | | | |
| a) 340-870WG | CV Shaft, 540 RPM | 2,234.00 | 1,519.12 |
| b) 340-648WG | CV Shaft, 1000 RPM | 1,850.00 | 1,258.00 |
| C185-196 | Equal Angle Hitch Kit w/ 540 RPM Shaft | 3,966.00 | 2,696.88 |

~ ~ Selection 3 ~ Choose a Clevis ~ ~

| | | | |
|------------|-----------------------------------|--------|--------|
| C000-506WG | Open Clevis (Minimum Requirments) | 541.00 | 367.88 |
| C000-500WG | Precision hitch | 979.00 | 665.72 |
| C000-513WG | Solid Tongue | 629.00 | 427.72 |
| C000-510WG | Pro Level Hitch | 856.00 | 582.08 |

~ ~ Selection 4 ~ Choose a Center Axle Mount Style ~ ~

| | | | |
|----------|---|----------|----------|
| C185-820 | Walking (Axles Included) | 3,382.00 | 2,299.76 |
| C185-830 | Non Walking (2 Tire Kit, Axles Included) | 1,205.00 | 819.40 |
| C185-825 | Non Walking (4 Tire Kit, Axles Included) | 1,869.00 | 1,270.92 |
| C186-880 | Wheel Mounts For Large Tires (Includes hubs/spindles & Tires) | 4,695.00 | 3,192.60 |

If choosing the C186-880, you MUST choose the C185-840 wing axle mount & one tire

MASTER PRICE SHEET



Schulte Industries Ltd.

100 John Schulte Dr., Englefeld, SK. Canada, S0K 1N0

Tel: 306-287-3715 Fax: 306-287-3355 Toll Free: 1-800-404-6044

Web: www.Schulte.ca

Sourcewell - Road Right Of Way Maintenance Equipment

MACHINE PRICES AND SPECIFICATIONS

FX-1200C Rotary Cutter (DOT Configuration Options)



~ ~ Selection 5 ~ Choose a Wing Axle Mount Style ~ ~

| | | | |
|----------|---|----------|----------|
| C185-835 | Walking Axle <i>(Axle Included)</i> | 1,654.00 | 1,124.72 |
| C185-840 | Non Walking <i>(1 Tire Kit, Axle Included)</i> | 646.00 | 439.28 |
| C185-845 | Non Walking <i>(2 Tire Kit, Axles Included)</i> | 854.00 | 580.72 |

~ ~ Selection 6 ~ Choose a Safety Guard ~ ~

| | | | |
|----------|----------------------------------|----------|--------|
| C190-520 | Chain Guards Single Front & Rear | 1,131.00 | 769.08 |
| C190-500 | Chain Guards Double Front & Rear | 1,452.00 | 987.36 |

~ ~ Selection 7 ~ Choose The Pan Kit ~ ~

| | | | |
|----------|--------------------|----------|----------|
| C317-450 | Pan Kit (required) | 1,780.00 | 1,210.40 |
|----------|--------------------|----------|----------|

~ ~ Selection 8 ~ Choose a Blade Configuration ~ ~

| | | | |
|----------|---------------------------|--------|--------|
| C317-451 | Updraft Blades, CW Center | 523.00 | 355.64 |
|----------|---------------------------|--------|--------|

~ ~ Selection 10 ~ Choose a Tire Option ~ ~

Please state the quantity of tires that you would like to order as the numbers listed below are single tires and not tire kits.

| | | Retail Price/Tire | Contract Price/Tire |
|------------|---|-------------------|---------------------|
| 210-003WG | Solid Laminated Tires, 6 x 9 x 20 | 380.00 | 258.40 |
| 210-175WG | Tire Assy, Forklift, 6.5 x 10 - 12 ply on 2 pce 5 bolt rim | 533.00 | 362.44 |
| 210-175FWG | Foam Filled Forklift Tire 6.5 x 10 - 12 ply on 2 pce 5 bolt rim | 924.00 | 628.32 |
| 210-540WG | Tire 24x8-14 20 Ply Rated Severe Duty | 622.00 | 422.96 |
| 210-540FWG | Tire 24x8-14 20 Ply Rated Severe Duty Foam Filled | 981.00 | 667.08 |
| 210-192WG | Solid Laminated Tire, 6 x 9 x 26 | 609.00 | 414.12 |

~ ~ Selection 11 ~ Choose a Destination Code ~ ~

| | | | |
|---------|---------------------------------------|-------|-------|
| C195-NA | North American & Australian Decal Kit | 71.00 | 48.28 |
|---------|---------------------------------------|-------|-------|

MASTER PRICE SHEET



Schulte Industries Ltd.

100 John Schulte Dr., Englefeld, SK. Canada, S0K 1N0

Tel: 306-287-3715 Fax: 306-287-3355 Toll Free: 1-800-404-6044

Web: www.Schulte.ca

Sourcewell - Road Right Of Way Maintenance Equipment

MACHINE PRICES AND SPECIFICATIONS

FX-1200C Rotary Cutter (DOT Configuration Options)



~ ~ Selection 12 ~ Choose a Extra Options ~ ~

| | | | |
|----------|--|-----------------|---------------|
| C185-304 | Strut Mount for Flex Arm,(Factory Installed) | 1,040.00 | 707.20 |
| C185-305 | Strut Mount for Flex Arm, (parts only) | 436.00 | 296.48 |
| C185-325 | Tension Link Leveling Rod , Factory Installed | 368.00 | 250.24 |
| C185-330 | Tension Link Leveling Rod , Weld on Parts only | 459.00 | 312.12 |
| C000-620 | Toolbox Mount & Toolbox | 1,466.00 | 996.88 |
| | Assembly Charge | Net | 300.00 |

IMPORTANT:

- 2) OSHA, ASAE, SAE, and ANSI standards REQUIRE the use of Chain Guards, Deflectors, or Solid Skirts/Bands at all times. Schulte recommends mower be equipped with deflectors or double chain guards for all mowing purposes. Single chain guards may be used for agricultural purposes only and are specifically not recommended for highway, right-of-way, parks or greenbelt mowing. Before ordering a mower, read the Thrown Object Shield Message in the Rotary Cutter Spec section in sales price book.



MASTER PRICE SHEET



Schulte Industries Ltd.

100 John Schulte Dr., Englefeld, SK. Canada, S0K 1N0

Tel: 306-287-3715 Fax: 306-287-3355 Toll Free: 1-800-404-6044

Web: www.Schulte.ca

Sourcewell - Road Right Of Way Maintenance Equipment

MACHINE PRICES AND SPECIFICATIONS

GX-150 Rotary Cutter



CUTTER FEATURES

- 540/1000 RPM Drive
- High inertia blade carrier
- Replaceable Skid Shoes
- 10 ga Single Domed Deck
10000lbs cap.)
- Deck Protection Rings
- Over Center Folding Wings
- 80 Degree CV Drive
- Height Control Cylinder & Hoses
- Wing Lift Cylinders & Hoses
- S000-010 Safety Chain (1/4" gr.70 -
- Operator's and Parts Manual Holder
- Cutting Width 180" (4.57m)

~ ~ Selection 1 ~ Choose a Basic Unit, Drive Package ~ ~

| | | Retail Price | Contract Price |
|-------------------------|---|--------------|----------------|
| C170-100 | GX-150 Base Unit | 23,704.00 | 16,118.72 |
| S000-085 | Safety Light Kit (Required) | 814.00 | 553.52 |
| Choose a Drive Package: | | | |
| a) | C170-705 Drive Package, CW Center, 540 RPM | 6,305.00 | 4,287.40 |
| b) | C170-715 Drive Package, CW Center, 1000 RPM | 6,305.00 | 4,287.40 |

~ ~ Selection 2 ~ Choose a Hitch Option ~ ~

| | | | |
|--------------------|------------------------------|----------|----------|
| C185-180 | Trailing Hitch, CV Style | 1,219.00 | 828.92 |
| Choose a CV Shaft: | | | |
| a) | 340-834WG CV Shaft, 540 RPM | 1,495.00 | 1,016.60 |
| b) | 340-676WG CV Shaft, 1000 RPM | 1,250.00 | 850.00 |

~ ~ Selection 3 ~ Choose a Clevis ~ ~

| | | | |
|------------|----------------------------|--------|--------|
| C000-510WG | Pro Level Hitch (Required) | 856.00 | 582.08 |
|------------|----------------------------|--------|--------|

~ ~ Selection 4 ~ Choose a Safety Guard ~ ~

| | | | |
|----------|------------------------------------|----------|----------|
| C180-520 | Chain Guards Single Front and Rear | 1,644.00 | 1,117.92 |
| C180-500 | Chain Guards Double Front and Rear | 2,098.00 | 1,426.64 |

~ ~ Selection 5 ~ Choose a Pan Kit ~ ~

| | | | |
|----------|--------------------|----------|----------|
| C170-450 | Pan Kit (required) | 2,268.00 | 1,542.24 |
|----------|--------------------|----------|----------|

MASTER PRICE SHEET



Schulte Industries Ltd.

100 John Schulte Dr., Englefeld, SK. Canada, S0K 1N0

Tel: 306-287-3715 Fax: 306-287-3355 Toll Free: 1-800-404-6044

Web: www.Schulte.ca

Sourcewell - Road Right Of Way Maintenance Equipment

MACHINE PRICES AND SPECIFICATIONS

GX-150 Rotary Cutter



~ ~ Selection 6 ~ Choose a Blade Configuration ~ ~

| | | | |
|----------|--|--------|--------|
| C316-451 | CW Schulte Super Suction Updraft 4" Blades | 777.00 | 528.36 |
|----------|--|--------|--------|

~ ~ Selection 7 ~ Choose an Axle Kit ~ ~

| | | | |
|----------|----------------------|----------|----------|
| C180-484 | Axle Kit for 4 Tires | 997.00 | 677.96 |
| C180-486 | Axle Kit for 6 Tires | 1,582.00 | 1,075.76 |
| C180-488 | Axle Kit for 8 Tires | 2,245.00 | 1,526.60 |

~ ~ Selection 8 ~ Choose a Tire Option ~ ~

Please state the quantity of tires that you would like to order as the number listed below is single tires and not tire kits.

| | | | |
|-----------|--|--------|--------|
| 210-175WG | Forklift Tire 6.5 x 10, 12 ply rated on 2 pce 5 bolt rim | 533.00 | 362.44 |
| 210-192WG | Solid Laminated Tire, 6 x 9 x 26 | 609.00 | 414.12 |
| 210-003WG | Solid Laminated Tires, 6 x 9 x 20 | 380.00 | 258.40 |

~ ~ Selection 9 ~ Choose a Destination Code ~ ~

| | | | |
|---------|---------------------------------------|-------|-------|
| C170-NA | North American & Australian Decal Kit | 78.00 | 53.04 |
|---------|---------------------------------------|-------|-------|

~ ~ Selection 10 ~ Choose Extra Options ~ ~

| | | | |
|----------|---|----------|--------|
| C185-325 | Tension Link Leveling Rod , Factory Installed | 368.00 | 250.24 |
| C000-620 | Toolbox Mount & Toolbox | 1,466.00 | 996.88 |

| | | |
|------------------------------|-----|--------|
| Assembly Charge on Pan Units | Net | 300.00 |
|------------------------------|-----|--------|

PREDELIVERY SERVICE IS REQUIRED BY DEALER OR END USER



MASTER PRICE SHEET



Sourcewell - Road Right Of Way Maintenance Equipment

Schulte Industries Ltd.

100 John Schulte Dr., Englefeld, SK. Canada, S0K 1N0

Tel: 306-287-3715 Fax: 306-287-3355 Toll Free: 1-800-404-6044

Web: www.Schulte.ca

MACHINE PRICES AND SPECIFICATIONS

GX-130 Rotary Cutter



CUTTER FEATURES

- 540 RPM Drive
- High inertia blade carrier
- Replaceable Skid Shoes
- 10 ga Single Domed Deck
- Deck Protection Rings
- Over Center Folding Wings
- Transport Width (max with duals on wings) 110"(2.79m)
- Transport Width (max with one 26" tire on wings) 99"(2.51m)
- 80 Degree CV Drive
- Height Control Cylinder & Hoses
- Wing Lift Cylinders & Hoses
- S000-010 Safety Chain (1/4" gr.70 - 10000lbs cap.)
- Operator's and Parts Manual Holder
- Cutting Width 13 ft (3.96m)

~ ~ Selection 1 ~ Choose a Basic Unit, Drive Package ~ ~

| | | Retail Price | Contract Price |
|-------------------------|---|--------------|----------------|
| C130-100 | GX-130 Base Unit (Required) | 22,765.00 | 15,480.20 |
| S000-085 | Safety Light Kit (Required) | 814.00 | 553.52 |
| Choose a Drive Package: | | | |
| a) | C130-705 Drive Package, CW Center, 540 RPM (Required) | 4,860.00 | 3,304.80 |

~ ~ Selection 2 ~ Choose a Hitch Option & Power Shaft ~ ~

| | | | |
|--------------------|--|----------|----------|
| C185-180 | Trailing Hitch, CV Style (Required) | 1,219.00 | 828.92 |
| Choose a CV Shaft: | | | |
| a) | 340-834WG CV Shaft, 540 RPM (Required) | 1,495.00 | 1,016.60 |

~ ~ Selection 3 ~ Choose a Clevis ~ ~

| | | | |
|------------|-----------------|--------|--------|
| C000-510WG | Pro Level Hitch | 856.00 | 582.08 |
| C000-513WG | Solid tongue | 629.00 | 427.72 |

~ ~ Selection 4 ~ Choose a Safety Guard ~ ~

| | | | |
|----------|------------------------------------|----------|----------|
| C130-520 | Chain Guards Single Front and Rear | 1,398.00 | 950.64 |
| C130-500 | Chain Guards Double Front and Rear | 1,625.00 | 1,105.00 |

~ ~ Selection 5 ~ Choose a Pan Kit ~ ~

| | | | |
|----------|--------------------|----------|----------|
| C130-450 | Pan Kit (Required) | 1,793.00 | 1,219.24 |
|----------|--------------------|----------|----------|

MASTER PRICE SHEET



Sourcwell - Road Right Of Way Maintenance Equipment

Schulte Industries Ltd.

100 John Schulte Dr., Englefeld, SK. Canada, S0K 1N0

Tel: 306-287-3715 Fax: 306-287-3355 Toll Free: 1-800-404-6044

Web: www.Schulte.ca

MACHINE PRICES AND SPECIFICATIONS

GX-130 Rotary Cutter



~ ~ Selection 6 ~ Choose a Blade Configuration ~ ~

| | | | |
|----------|---|--------|--------|
| C130-451 | CW Schulte Super Suction Updraft 4" Blades (Required) | 803.00 | 546.04 |
|----------|---|--------|--------|

~ ~ Selection 7 ~ Choose an Axle Kit ~ ~

| | | | |
|----------|---|----------|----------|
| C180-484 | Axle Kit for 4 Tires (Two tires on center, one tire on each wing) | 997.00 | 677.96 |
| C180-486 | Axle Kit for 6 Tires (Duals on center, one tire on each wing) | 1,582.00 | 1,075.76 |

~ ~ Selection 8 ~ Choose a Tire Option ~ ~

Please state the quantity of tires that you would like to order as the numbers listed below are single tires and not tire kits.

| | | | |
|-----------|--|--------|--------|
| 210-175WG | Forklift Tire 6.5 x 10, 12 ply rated on 2 pce 5 bolt rim | 533.00 | 362.44 |
| 210-003WG | Solid Laminated Tires, 6 x 9 x 20 | 380.00 | 258.40 |

~ ~ Selection 9 ~ Choose a Destination Code ~ ~

| | | | |
|---------|--|-------|-------|
| C130-NA | North American & Australian Decal Kit (Required For North America) | 78.00 | 53.04 |
|---------|--|-------|-------|

~ ~ Selection 10 ~ Choose Extra Options ~ ~

| | | | |
|----------|---|--------|--------|
| C130-250 | Wheel Covers <i>(For use in orchards to prevent the tires from grabbing fruit)</i> | 586.00 | 398.48 |
| | Assembly Charge on Pan Units | Net | 300.00 |

PREDELIVERY SERVICE IS REQUIRED BY DEALER OR END USER

IMPORTANT:

- 1) Safety Chain Kit must be used at all times when moving equipment on any type of road.
- 2) OSHA, ASAE, SAE, and ANSI standards REQUIRE the use of Chain Guards, Deflectors, or Solid Skirts/Bands at all times. Schulte recommends mower be equipped with deflectors or double chain guards for all mowing purposes. Single chain guards may be used for agricultural purposes only and are specifically not recommended for highway, right-of-way, parks or greenbelt mowing. Before ordering a mower, read the Thrown Object Shield Message in the Rotary Cutter Spec section in sales price book.



MASTER PRICE SHEET



Schulte Industries Ltd.

100 John Schulte Dr., Englefeld, SK. Canada, S0K 1N0

Tel: 306-287-3715 Fax: 306-287-3355 Toll Free: 1-800-404-6044

Web: www.Schulte.ca

Sourcewell - Road Right Of Way Maintenance Equipment

MACHINE PRICES AND SPECIFICATIONS

FLX-1510 Flex Arm



FLEX ARM FEATURES

- New heavy duty 111 x 15, 2 ply tires, load cap. Of 4000 lbs
- Cut directly in-line with the tractor or at any offset distance upto 122"
- 6000 lb capacity, 6 bolt hubs
- Spring steel bushings, induction harden pins at major pivot points
- Minimum of 3 hydraulic circuits required to operate with 15' or 10' mower
- Heavy duty 3-1/2 x 36 welded hydraulic cylinder
- Opt. 6 port selector valve kit for independent wing action or limited tractor hydraulic outlets
- Continuous power rating 200hp @ 1000rpm
- Bolt in replacement axles
- Safety light kit
- Operator's manual in holder

~ ~ Selection 1 ~ Choose a Basic Unit ~ ~

| | | Retail Price | Contract Price |
|----|----------------------------------|--------------|----------------|
| 1) | A105-000 FLX 1510 Flexarm | 42,015.00 | 28,570.20 |

~ ~ Selection 2 ~ Choose a Flex Arm Strut ~ ~

| | | | |
|----|---|--------|--------|
| 1) | A105-127WG Strut for attaching a XH1000/XH1500 | 415.00 | 282.20 |
| 2) | A105-227WG Strut for attaching a FX1200/FX1800 | 415.00 | 282.20 |

~ ~ Selection 3 ~ Choose Tires ~ ~

| | | | |
|----|---|----------|----------|
| 1) | 210-514WG Tire, 12 x 16.5 Skid Steer Tire | 1,490.00 | 1,013.20 |
| 2) | 210-330WG Tire, 33 x 12, Non-Directional 231 Boss Solid No Puncture Tire | 2,525.00 | 1,717.00 |

~ ~ Selection 4 ~ Extra Options ~ ~

| | | | |
|----|---|----------|--|
| 1) | A105-350 Six Port Selector Valve Kit for Independent Wing <i>Must pick if the tractor has only 3 valve banks, and the Flex Arm is being hooked to a 15' cutter</i> | 2,240.00 | 1,523.20 |
| 2) | A105-360 Hose kit for independent wing lift- Tractors with 4 valve banks <i>Must pick if the tractor has 4 valve banks, and the Flex Arm is being hooked to a 15' cutter</i> | 389.00 | 264.52 |
| 3) | C306-835 Independent Double Acting Cylinder Kit <i>XH1500 S4 Only - Hose kit for XH1500 to make independent wing lift, only order if the mower does not have it and the customer wants to have down pressure on the wings</i> | | * To order this kit, please contact the Schulte Parts Department |
| 4) | C307-835 Independent Double Acting Cylinder Kit <i>XH1000 S4 Only - Hose kit for XH1000 to make independent wing lift, only order if the mower does not have it and the customer wants to have down pressure on the wing</i> | | * To order this kit, please contact the Schulte Parts Department |
| 5) | C000-300WG Precision Hitch <i>Precision hitch only, customer will receive precision hitch as well as the adjustable clevis (Standard)</i> | 695.00 | 472.60 |

Assembly

Net 300.00

IMPORTANT: OSHA, ASAE, SAE, and ANSI standards REQUIRE the use of Chain Guards, Deflectors, or Solid Skirts/Bands at all times. Schulte recommends mower be equipped with deflectors or double chain guards for all mowing purposes. Single chain guards may be used for agricultural purposes only and are specifically not recommended for highway, right-of-way, parks or greenbelt mowing. Before ordering a mower, read the Thrown ObjectShield Information Message in the Rotary Cutter Spec Section in the sales price book.



MASTER PRICE SHEET



Schulte Industries Ltd.

100 John Schulte Dr., Englefeld, SK. Canada, S0K 1N0

Tel: 306-287-3715 Fax: 306-287-3355 Toll Free: 1-800-404-6044

Web: www.Schulte.ca

Sourcwell - Road Right Of Way Maintenance Equipment

MACHINE PRICES AND SPECIFICATIONS

FX-209 Rotary Cutter



CUTTER FEATURES - ALL HITCH TYPES

- Push or pull capability
- 9ft / 3m overall width
- Cutting Height: 2" - 13" (5.1 cm - 33 cm)
- Cutting Width: 109.25" (2.78 m)
- Cutting Capacity: 3" (7.6 cm)
- Minimum Tractor HP 50 HP (37.3 kW)
- Cat. II & III 3 Point / Semi Mount Swing (13" left or right swing), Trailing Pull
- Gearbox Rating 210 hp
- Two rotor base unit common to all configuration
- Pans with Schulte Super Suction Blades
- Double Chain Front & Rear
- 7 Ga Deck
- 540 and 1000 RPM drive options

~ ~ Selection 1 ~ Choose a FX-209 Base Unit ~ ~

| | | Retail Price | Contract Price |
|----------|------------------|--------------|----------------|
| C209-100 | FX-209 Base Unit | 14,493.00 | 9,855.24 |

~ ~ Selection 2 ~ Choose a FX-209 Non Trailing Configuration ~

| | | | |
|----------|--|----------|----------|
| | Choose One Mount | | |
| C209-300 | 3PT Mount Option | 3,367.00 | 2,289.56 |
| | Choose One Drive Package | | |
| C209-710 | 540 RPM Drive Package <i>NON-TRAILING</i> or | 2,450.00 | 1,666.00 |
| C209-715 | 1000 RPM Drive Package <i>NON-TRAILING</i> | 2,450.00 | 1,666.00 |
| | Choose One Wheel Assembly | | |
| C209-400 | FX-209 Wheel Assembly Non-Trailing Standard or | 3,020.00 | 2,053.60 |
| C209-450 | FX-209 Wheel Assembly Non-Trailing Hydraulic | 4,354.00 | 2,960.72 |

~ ~ Selection 3 ~ Choose a FX-209 Trailing Hitch Configuration ~

| | | | |
|------------|---|----------|----------|
| C209-340 | FX-209 Trailing Hitch | 6,332.00 | 4,305.76 |
| CS01-106WG | Open Clevis (<i>Minimum Requirement</i>) or | 254.00 | 172.72 |
| C000-360WG | Adjustable Clevis or | 382.00 | 259.76 |
| C000-300WG | Precision Hitch or | 695.00 | 472.60 |
| C502-113WG | Solid Tongue | 321.00 | 218.28 |
| | Choose One Drive Package | | |
| C209-700 | 540 RPM Drive Package Trailing or | 4,395.00 | 2,988.60 |
| C209-705 | 1000 RPM Drive Package Trailing | 4,551.00 | 3,094.68 |

MASTER PRICE SHEET



Schulte Industries Ltd.

100 John Schulte Dr., Englefeld, SK. Canada, S0K 1N0

Tel: 306-287-3715 Fax: 306-287-3355 Toll Free: 1-800-404-6044

Web: www.Schulte.ca

Sourcwell - Road Right Of Way Maintenance Equipment

MACHINE PRICES AND SPECIFICATIONS

FX-209 Rotary Cutter



~~ Selection 4 ~ Choose Options ~~

| | | | |
|----------|---|----------|----------|
| C209-250 | BLADE PAN OPTION (Must Pick) | 2,270.00 | 1,543.60 |
| C209-520 | HALF LENGTH BELTING OPTION (Front and Back) | 366.00 | 248.88 |

~~ Selection 5 ~ Choose Tire Options ~~

(CHOOSE 2 TIRES PER UNIT)

| | | Retail Price/Tire | Contract Price/Tire |
|------------|---|-------------------|---------------------|
| 210-003WG | Solid Laminated Tires, 6 x 9 x 20 | 380.00 | 258.40 |
| 210-540WG | Tire 24x8-14 20 Ply Rated Severe Duty | 622.00 | 422.96 |
| 210-540FWG | Tire 24x8-14 20 Ply Rated Severe Duty Foam Filled | 981.00 | 667.08 |
| 210-175WG | Forklift New, 6.5 x 10 - 12 ply rated on 2 pcs 5 bolt rim | 533.00 | 362.44 |
| 210-175FWG | Foam Filled Forklift Tire 6.5 x 10 - 12 ply on 2 pce 5 bolt rim | 924.00 | 628.32 |

Assembly

Net

300.00



MASTER PRICE SHEET



Schulte Industries Ltd.

100 John Schulte Dr., Englefeld, SK. Canada, S0K 1N0

Tel: 306-287-3715 Fax: 306-287-3355 Toll Free: 1-800-404-6044

Web: www.Schulte.ca

Sourcewell - Road Right Of Way Maintenance Equipment

MACHINE PRICES AND SPECIFICATIONS



FX-107 Rotary Cutter

CUTTER FEATURES - ALL HITCH TYPES

- Rigid single domed 7 gauge deck construction
- Overall width: 95.5" (2.43 m)
- Cutting Height: 3" - 12 7/8" (7.6 cm - 33 cm)
- Cutting Width: 84" (2.13 m)
- Cutting Capacity: 3" (7.6 cm)
- Minimum Tractor HP 50 HP (37.3 kW)
- Cat. II & III 3 Point / Trailing Pull
- Pull type and 3 point hitch options
- Base unit common to all configurations
- 540 RPM drive
- Double Chain Front & Rear
- 7 Ga Deck
- Pull type unit has the ability to accept open clevis, solid tongue & adjustable clevis

~ ~ Selection 1 ~ Choose a Base Unit ~ ~

| | | Retail Price | Contract Price |
|----------|------------------|--------------|----------------|
| C107-100 | FX-107 Base Unit | 9,950.00 | 6,766.00 |

~ ~ Selection 2 ~ Choose a 3 Point Option Configuration ~ ~

| | | | |
|----------|--|----------|----------|
| C107-300 | 3PT Mount Option <i>(if this choosen skip Trailing Hitch Option)</i> | 5,667.00 | 3,853.56 |
|----------|--|----------|----------|

~ ~ Selection 3 ~ Choose a Trailing Hitch Configuration ~ ~

| | | | |
|------------|---|----------|----------|
| C107-195 | Trailing Hitch | 7,945.00 | 5,402.60 |
| CS01-106WG | Open Clevis <i>(Minimum Requirement) or</i> | 254.00 | 172.72 |
| C000-360WG | Adjustable Clevis <i>or</i> | 382.00 | 259.76 |
| C000-300WG | Precision Hitch <i>or</i> | 695.00 | 472.60 |
| C502-113WG | Solid Tongue | 321.00 | 218.28 |

~ ~ Selection 4 ~ Blade Pan Option ~ ~

| | | | |
|----------|------------------------------|----------|----------|
| C107-250 | BLADE PAN OPTION (Must Pick) | 1,471.00 | 1,000.28 |
|----------|------------------------------|----------|----------|

~ ~ Selection 5 ~ Choose Tire Options ~ ~

| | | Retail Price/Tire | Contract Price/Tire |
|----------------------------------|---|-------------------|---------------------|
| (CHOOSE 2 TIRES PER UNIT) | | | |
| 210-003WG | Solid Laminated Tires, 6 x 9 x 20 | 380.00 | 258.40 |
| 210-540WG | Tire 24x8-14 20 Ply Rated Severe Duty | 622.00 | 422.96 |
| 210-540FWG | Tire 24x8-14 20 Ply Rated Severe Duty Foam Filled | 981.00 | 667.08 |
| 210-175WG | Forklift New, 6.5 x 10 - 12 ply rated on 2 pcs 5 bolt rim | 533.00 | 362.44 |
| 210-175FWG | Foam Filled Forklift Tire 6.5 x 10 - 12 ply on 2 pce 5 bolt rim | 924.00 | 628.32 |

Assembly

Net

250.00



MASTER PRICE SHEET



Schulte Industries Ltd.

100 John Schulte Dr., Englefeld, SK. Canada, S0K 1N0

Tel: 306-287-3715 Fax: 306-287-3355 Toll Free: 1-800-404-6044

Web: www.Schulte.ca

Sourcewell - Road Right Of Way Maintenance Equipment

MACHINE PRICES AND SPECIFICATIONS

Eliminator



ELIMINATOR FEATURES

- Chemical application spray kit for XH1500
- Adjustable Flow rate (can be matched to the product you are using)
- Monitor for speed, pressure and application rates
- 50 US Gallon (189 Litres) Capacity Tank
- Great for brush and weed control
- Reduce drift while mowing-
Spraying is done unbdter the deck

~ ~ Selection 1 ~ Choose a Basic Unit ~ ~

| | <i>Retail Price</i> | <i>Contract Price</i> |
|--|---------------------|-----------------------|
| 1) C350-675 Eliminator Spray Kit - Series 5 | 15,318.00 | 10,416.24 |
| Factory Installation on XH1500 | Net | 675.00 |
| Crated For Shipping | Net | 200.00 |





United States Price List Index

Schulte Industries Ltd.

100 John Schulte Dr., Englefeld, SK. Canada, S0K 1N0

Tel: 306-287-3715 Fax: 306-287-3355 Toll Free: 1-800-404-6044

Web: www.Schulte.ca



Sourcewell - Road Right Of Way Maintenance Equipment



Click on this symbol to
return to this index page

Rotary Cutters

FX742 - 42 Ft Rotary Cutter

FX530 - 30 Ft Rotary Cutter

5026 - 26 Ft Rotary Cutter

5024 - 24 Ft Rotary Cutter

FX520 - 20 Ft Rotary Cutter

FX320 - 20 Ft Rotary Cutter

FX318 - 18 Ft Rotary Cutter

FX212 - 12 Ft Rotary Cutter

TPX-318 3PT - 18 Ft Rotary Cutter

XH1500 Series 5 - 15 Ft Rotary Cutter

SFT Pro XH1500 Series 5 - 15 Ft Rotary Cutter

Cutter Command System - XH1500 Series 5 / XH1000 Series 5

XH1000 Series 5 - 10 Ft Rotary Cutter

FX1800 - 15 Ft Rotary Cutter

FX1800C - 15 Ft Rotary Cutter (DOT Configuration Options)

FX1200 - 10 Ft Rotary Cutter

FX1200C - 10 Ft Rotary Cutter (DOT Configuration Options)

GX150 - 15 Ft Rotary Cutter

GX130 - 13 Ft Rotary Cutter

FLX1510 - Flex Arm For 10' & 15' Schulte Rotary Cutters

FX209 - 9 Ft Rotary Cutter

FX107 - 7 Ft Rotary Cutter

Eliminator Spray Kit For XH1500 Rotary Cutters

MASTER PRICE SHEET



Schulte Industries Ltd.

100 John Schulte Dr., Englefeld, SK. Canada, S0K 1N0

Tel: 306-287-3715 Fax: 306-287-3355 Toll Free: 1-800-404-6044

Web: www.Schulte.ca



Sourcewell - Road Right Of Way Maintenance Equipment

MACHINE PRICES AND SPECIFICATIONS

FX-742 Rotary Cutter

~ The World's Largest Rotary Cutter ~

CUTTER FEATURES

- 42ft Cutting Width (12.8 m)
- 2" - 16" Cutting Height (51-406 mm)
- 118" Transport Width (3m)
- 10 ga Domed Deck (3.4 mm)
- Replaceable 2 Piece Skid Shoes
- 2" Cutting Capacity (51 mm)
- 250hp Minimum Tractor Size
- Floating Hitch
- 10 Gearbox Layout with
- 7 Slip Clutches (7 down clutches)
- 18,000 lbs Total Weight (8,165 kgs)
- Hydraulic Phasing & Mechanical Hybrid Lift System with Hydraulic Depth Control
- Adjustable Wheel Standards
- 1 Year Full Warranty & 3 Years Limited Gearbox Warranty
- Easy to Use Safety Lock Up

~ ~ Selection 1 ~ Choose a Basic Unit ~ ~

| | | Retail Price | Contract Price |
|----------|-----------------------------|--------------|----------------|
| C742-100 | FX742 Rotary Cutter | 154,536.00 | 105,084.48 |
| S000-097 | Safety Light Kit (Required) | 681.00 | 463.08 |

~ ~ Selection 2 ~ Choose Hitch ~ ~

| | | | |
|----------|---|----------|----------|
| C742-855 | Trailing Hitch, CV Style w/ Manual Hitch Jack | 4,308.00 | 2,929.44 |
| C742-335 | Trailing Hitch, CV Style w/ Hydraulic Jack | 5,233.00 | 3,558.44 |

~ ~ Selection 3 ~ Choose Axle and Tire Configuration ~ ~

| | | | |
|----------|---|-----------|----------|
| C742-630 | Through Axle Kit - Choose 10 Tires | 8,750.00 | 5,950.00 |
| C742-635 | Walking Axle Kit - Choose 14 Tires | 14,530.00 | 9,880.40 |

~ ~ Selection 4 ~ Choose Tire Option ~ ~

| | | Retail Price/Tire | Contract Price/Tire |
|-----------|--|-------------------|---------------------|
| 210-560WG | Tire Assembly Stubble Proof (Choose Quantity of Tires Need - 10 or 14) | 756.00 | 514.08 |

~ ~ Selection 5 ~ Choose a Blade Configuration ~ ~

| | | | |
|----------|--|-----------|-----------|
| C742-250 | Pan Kit with Updraft Blades | 9,279.00 | 6,309.72 |
| C742-265 | Fixed Knife Kit with Flat Double Sided Blades & Shrouds (For Cotton) | 14,830.00 | 10,084.40 |
| C742-270 | Fixed Knife Kit with Updraft Blades & Shrouds | 14,830.00 | 10,084.40 |

* Above prices subject to a 4% steel tariff surcharge

MASTER PRICE SHEET



Schulte Industries Ltd.

100 John Schulte Dr., Englefeld, SK. Canada, S0K 1N0

Tel: 306-287-3715 Fax: 306-287-3355 Toll Free: 1-800-404-6044

Web: www.Schulte.ca



Sourcewell - Road Right Of Way Maintenance Equipment

MACHINE PRICES AND SPECIFICATIONS

FX-742 Rotary Cutter

~ The World's Largest Rotary Cutter ~

~ ~ Selection 6 ~ Choose a Safety Guard & Accessories ~ ~

| | | | |
|----------|--|----------|----------|
| C742-500 | Single Chains Front & Rear | 4,938.00 | 3,357.84 |
| C742-525 | Double Chains Front and Rear | 5,553.00 | 3,776.04 |
| C742-550 | Front & Rear Rubber Belting | 2,903.00 | 1,974.04 |
| C742-580 | Single Chains Front & Rear with Front Rubber Belting | 5,824.00 | 3,960.32 |

~ ~ Selection 7 ~ Choose Wheel Extension Kit ~ ~

| | | | |
|----------|--|----------|----------|
| C742-350 | Row Crop Wheel Extensions <i>(Will accommodate 30", 32", 36", 38", 40" + 1m rows)</i> <i>(Transport width of 146" or 3.7m)</i> | 1,523.00 | 1,035.64 |
|----------|--|----------|----------|

NOTE: All Tires Are 11L x 15 x 12 Ply Rated

~ ~ Selection 8 ~ Choose a Destination Code ~ ~

| | | | |
|---------|--------------------------------|--------|--------|
| C742-NA | North American Destination Kit | 295.00 | 200.60 |
|---------|--------------------------------|--------|--------|

~ ~ Selection 9 ~ Options ~ ~

| | | | |
|----------|---|-----------|----------|
| C742-780 | Fan Debris Kit, Factory Installed | 14,356.00 | 9,762.08 |
| C742-790 | Fan Debris Kit, Crated | 13,949.00 | 9,485.32 |
| | Assembly charge on pan units | Net | 1,300.00 |
| | Assembly charge on fixed blade units | Net | 1,400.00 |

IMPORTANT: Safety Tow Chain Kit must be used at all times when moving equipment on any type of road.

IMPORTANT: OSHA, ASAE, SAE, and ANSI standards REQUIRE the use of Chain Guards, Deflectors, or Solid Skirts/Bands at all times. Schulte recommends mower be equipped with deflectors or double chain guards for recommended for highway, right-of-way, parks or greenbelt mowing. Before ordering a mower, read the Thrown Object Shield Information Message in the Rotary Cutter Spec Section in the sales price book.



* Above prices subject to a 4% steel tariff surcharge

MASTER PRICE SHEET



Schulte Industries Ltd.

100 John Schulte Dr., Englefeld, SK. Canada, S0K 1N0

Tel: 306-287-3715 Fax: 306-287-3355 Toll Free: 1-800-404-6044

Web: www.Schulte.ca



Sourcewell - Road Right Of Way Maintenance Equipment

MACHINE PRICES AND SPECIFICATIONS

FX-530 Rotary Cutter

CUTTER FEATURES

- 30' of mowing and shredding excellence
- Accommodates 30", 32", 36", 38" row spacings
 - Spun formed pans available on pan unit
- Excellent shredding and distribution capabilities on Fixed Knife units allows for
- Unique drive layout allows for clutch on every down box
- Phasing system for parallel lift cut
- Non-adjustable clutches provide low maintenance
- Available **Cyclone Deck Debris Fan Kit**
- 350 hp, 60° degree splitter gearbox
- Unique driveline layout
- Floating hitch with rubber grommet rear

~ ~ Selection 1 ~ Choose a Basic Unit, Drive Package ~ ~

| | | | <i>Retail Price</i> | <i>Contract Price</i> |
|----|----------|---------------------------------------|---------------------|-----------------------|
| 1) | C530-100 | Schulte FX-530, Basic Unit (Required) | 82,881.00 | 56,359.08 |
| 2) | S000-097 | Safety Light Kit (Required) | 681.00 | 463.08 |

~ ~ Selection 2 ~ Choose a Hitch Option ~ ~

| | | | | |
|----------|--|--|-----------------|-----------------|
| C530-810 | Trailing Hitch, CV Style | OR | 2,752.00 | 1,871.36 |
| C530-845 | Trailing Hitch, CV Style w/ Hydraulic Jack | | 4,508.00 | 3,065.44 |
| | Choose a Shaft | | | |
| a) | 340-885WG | 1 3/4 inch Tractor Shaft | 2,652.00 | 1,803.36 |
| b) | 340-875WG | 1 3/8 inch Tractor Shaft | 2,538.00 | 1,725.84 |
| C530-800 | Trailing Equal Angle Hitch Sub Assembly | | 2,847.00 | 1,935.96 |
| | Must Choose a Hitch Block | | | |
| a) | C502-821 | Category 3, fits up to a 1-1/2" pin and a drawbar 2-1/4" x 3-1/2" | 377.00 | 256.36 |
| b) | C502-822 | Category 4, fits up to a 2" pin and a drawbar 2-1/2" x 5-1/8" | 375.00 | 255.00 |
| | Choose a Tractor Shaft: | IMPORTANT: PTO Adaptor must not be used in any application. | | |
| a) | 340-5505WG | Equal Angle Shaft, 1 3/8" x 21 Spline | 1,283.00 | 872.44 |
| b) | 340-5509WG | Equal Angle Shaft, 1 3/4" x 20 Spline | 1,362.00 | 926.16 |

*** Above prices subject to a 4% steel tariff surcharge**

MASTER PRICE SHEET



Schulte Industries Ltd.

100 John Schulte Dr., Englefeld, SK. Canada, S0K 1N0

Tel: 306-287-3715 Fax: 306-287-3355 Toll Free: 1-800-404-6044

Web: www.Schulte.ca



Sourcewell - Road Right Of Way Maintenance Equipment

MACHINE PRICES AND SPECIFICATIONS

FX-530 Rotary Cutter

~ ~ Selection 3 ~ Choose an Extension Kit ~ ~

| | | | |
|----------|---------------------|----------|--------|
| C530-350 | Row Crop Extensions | 1,233.00 | 838.44 |
|----------|---------------------|----------|--------|

~ ~ Selection 4 ~ Choose an Axle Kit ~ ~

| | | | |
|----------|---|----------|----------|
| C530-625 | Non Walking Wheel Standards <i>(Choose 8 Tires)</i> | 6,424.00 | 4,368.32 |
| C530-635 | Walking Axles <i>(choose 10 Tires)</i> | 9,322.00 | 6,338.96 |
| C530-670 | Standard Axle Add-on <i>(Choose 2 tires)</i> | 1,907.00 | 1,296.76 |

~ ~ Selection 5 ~ Choose Tire Kit ~ ~

| | | Retail Price/Tire | Contract Price/Tire |
|-----------|---|-------------------|---------------------|
| 210-511WG | Light Truck Tires <i>(Choose quantity of tires needed 8, 10 or 2)</i> | 395.00 | 268.60 |
| 210-560WG | Tire Assembly Stubble Proof <i>(Choose quantity of tires needed 8, 10 or 2)</i> | 756.00 | 514.08 |

~ ~ Selection 6 ~ Choose a Pan or Fixed Knife Kit ~ ~

| | | | |
|----------|--|----------|----------|
| C530-250 | Pans and Updraft Blades | 6,216.00 | 4,226.88 |
| C530-270 | Fixed Knife Kit c/w Shrouds and Updraft Blades | 7,280.00 | 4,950.40 |
| C530-280 | Fixed Knife kit c/w Shrouds and <i>Non</i> Updraft Blades (For Cotton) | 7,280.00 | 4,950.40 |

~ ~ Selection 7 ~ Choose a Shielding Kit or Combination ~ ~

| | | | |
|----------|---------------------------|----------|----------|
| C530-500 | Front Single Chains | 1,463.00 | 994.84 |
| C530-510 | Rear Single Chains | 1,733.00 | 1,178.44 |
| C530-550 | Front Double Chains | 1,787.00 | 1,215.16 |
| C530-560 | Rear Double Chains | 2,129.00 | 1,447.72 |
| C530-570 | Half-length front belting | 535.00 | 363.80 |
| C530-575 | Half-length rear belting | 535.00 | 363.80 |
| C530-580 | Front Belting | 707.00 | 480.76 |
| C530-590 | Rear Belting | 707.00 | 480.76 |

* Above prices subject to a 4% steel tariff surcharge

MASTER PRICE SHEET



Schulte Industries Ltd.

100 John Schulte Dr., Englefeld, SK. Canada, S0K 1N0

Tel: 306-287-3715 Fax: 306-287-3355 Toll Free: 1-800-404-6044

Web: www.Schulte.ca



Sourcewell - Road Right Of Way Maintenance Equipment

MACHINE PRICES AND SPECIFICATIONS

FX-530 Rotary Cutter

~ ~ Selection 8 ~ Choose Destination Kit ~ ~

| | | | |
|---------|--------------------------|--------|--------|
| C530-NA | North American Decal Kit | 176.00 | 119.68 |
|---------|--------------------------|--------|--------|

~ ~ Selection 9 ~ Choose Options ~ ~

| | | | |
|----------|---|-----------|----------|
| C530-330 | Hydraulic Actuated Outer Wings | 1,811.00 | 1,231.48 |
| C530-780 | Cyclone Fan Debris Kit, Factory Installed | 14,108.00 | 9,593.44 |
| C530-790 | Cyclone Fan Debris Kit, Crated | 13,826.00 | 9,401.68 |
| | Assembly Charge on Pan Units | Net | 1,000.00 |
| | Assembly Charge on Fixed Blades | Net | 1,100.00 |

IMPORTANT:

- 1) Safety Chain Kit must be used at all times when moving equipment on any type of road.
- 2) OSHA, ASAE, SAE, and ANSI standards REQUIRE the use of Chain Guards, Deflectors, or Solid Skirts/Bands at all times. Schulte recommends mower be equipped with deflectors or double chain guards for all mowing purposes. Single chain guards may be used for agricultural purposes only and are specifically not recommended for highway, right-of-way, parks or greenbelt mowing. Before ordering a mower, read the Thrown Object Shield Message in the Rotary Cutter Spec section in sales price book.



* Above prices subject to a 4% steel tariff surcharge

MASTER PRICE SHEET



Schulte Industries Ltd.

100 John Schulte Dr., Englefeld, SK. Canada, S0K 1N0

Tel: 306-287-3715 Fax: 306-287-3355 Toll Free: 1-800-404-6044

Web: www.Schulte.ca



Sourcewell - Road Right Of Way Maintenance Equipment

MACHINE PRICES AND SPECIFICATIONS

5026 Rotary Cutter

CUTTER FEATURES

- 10GA deck
- Phasing cylinders (3) c/w hoses
- Wing lift cylinders (2) c/w hoses
- Suspension for center and wings
- Spring steel bushings at major pivot points
- 1000 RPM
- Deck protection rings
- S000-010 safety chain kit 1/4" grade 70 with 10,000 lbs capacity
- Two piece replaceable skid shoes
- Operator's manual in holder

~ ~ Selection 1 ~ Choose a Basic Unit ~ ~

| | | Retail Price | Contract Price |
|----|---|--------------|----------------|
| 1) | C502-100 Basic 26' Unit, 1000 RPM | 69,007.00 | 46,924.76 |
| 2) | S000-135 Safety Light Kit (Required) | 754.00 | 512.72 |

~ ~ Selection 2 ~ Choose a Hitch Type and Accessories ~ ~

| | | | |
|----|---|----------|----------|
| 1) | C502-810 Trailing hitch, CV Style | 1,461.00 | 993.48 |
| | Choose a Clevis: | | |
| a) | C502-113WG Solid Tongue | 279.00 | 189.72 |
| b) | C502-107WG Open Clevis | 206.00 | 140.08 |
| c) | C000-300WG Precision hitch | 631.00 | 429.08 |
| d) | C502-815WG Clevis with 2 3/16" Opening | 310.00 | 210.80 |
| e) | C502-816WG Solid Tongue with 2-3/16 hole for a 2" pin | 740.00 | 503.20 |
| | Choose a Tractor Shaft: | | |
| a) | 340-8082WG CV Shaft, 1 3/4" x 20 Spline | 2,630.00 | 1,788.40 |
| b) | 340-8092WG CV Shaft, 1 3/8" x 21 Spline | 2,630.00 | 1,788.40 |
| 2) | C502-820 Trailing Equal Angle Hitch Sub Assembly | 2,528.00 | 1,719.04 |
| | Must Choose a Hitch Block | | |
| a) | C502-821 Category 3, fits up to a 1-1/2" pin and a drawbar 2-1/4" x 3-1/2" | 377.00 | 256.36 |
| b) | C502-822 Category 4, fits up to a 2" pin and a drawbar 2-1/2" x 5-1/8" | 375.00 | 255.00 |
| | Choose a Tractor Shaft: | | |
| a) | 340-5505WG Equal Angle Shaft, 1 3/8" x 21 Spline | 1,283.00 | 872.44 |
| b) | 340-5509WG Equal Angle Shaft, 1 3/4" x 20 Spline | 1,362.00 | 926.16 |

IMPORTANT: PTO Adaptor must not be used in any application.

* Above prices subject to a 4% steel tariff surcharge

MASTER PRICE SHEET



Schulte Industries Ltd.

100 John Schulte Dr., Englefeld, SK. Canada, S0K 1N0

Tel: 306-287-3715 Fax: 306-287-3355 Toll Free: 1-800-404-6044

Web: www.Schulte.ca



Sourcewell - Road Right Of Way Maintenance Equipment

MACHINE PRICES AND SPECIFICATIONS

5026 Rotary Cutter

~ ~ Selection 3 ~ Choose a Blade Configuration ~ ~

| | | | |
|-----------------|--|-----------------|-----------------|
| C502-250 | Two Blade Pan Kit | 6,401.00 | 4,352.68 |
| C502-251 | Two Blade Pan Kit with Shredder Blades | 7,171.00 | 4,876.28 |
| C502-270 | Fixed Knife Shredder Kit with Updraft Blades | 9,802.00 | 6,665.36 |
| C502-280 | Fixed Knife Shredder Kit with Flat Blades <i>(recommended for cotton)</i> | 9,802.00 | 6,665.36 |

~ ~ Selection 4 ~ Choose a Safety Guard & Accessories ~ ~

| | | | |
|-----------------|--|-----------------|-----------------|
| C502-420 | Single Safety Chains Front & Rear c/w Front Rubber Belting (recommended for cotton & corn) | 3,350.00 | 2,278.00 |
| C502-430 | Single Safety Chains Front Only c/w Front & Rear Rubber Belting (recommended for dry grass staw, wheat straw & barley straw) | 2,603.00 | 1,770.04 |
| C502-500 | Single Safety Chains Front & Rear | 2,940.00 | 1,999.20 |
| C502-440 | Single Safety Chains Front & Rear c/w frt & rear belting | 4,259.00 | 2,896.12 |
| C502-550 | Double Safety Chains Front & Rear | 3,623.00 | 2,463.64 |

IMPORTANT: OSHA, ASAE, SAE, and ANSI standards REQUIRE the use of Chain Guards, Deflectors, or Solid Skirts/Bands at all times. Schulte recommends mower be equipped with deflectors or double chain guards for all mowing purposes. Single chain guards may be used for agricultural purposes only and are specifically not recommended for highway, right-of-way, parks or greenbelt mowing. Before ordering a mower, read the Thrown Object Shield Information Message in the Rotary Cutter Spec Section in the sales price book.

* Above prices subject to a 4% steel tariff surcharge

MASTER PRICE SHEET



Schulte Industries Ltd.

100 John Schulte Dr., Englefeld, SK. Canada, S0K 1N0
 Tel: 306-287-3715 Fax: 306-287-3355 Toll Free: 1-800-404-6044
 Web: www.Schulte.ca



Sourcewell - Road Right Of Way Maintenance Equipment

MACHINE PRICES AND SPECIFICATIONS

5026 Rotary Cutter

~ ~ Selection 5 ~ Choose Axle Option ~ ~

| | | | |
|-----------------|--|-----------------|-----------------|
| C502-643 | Standard Axle Kit <i>(Choose 6 Tires cannot use stubble proof tires)</i> | 5,055.00 | 3,437.40 |
| C502-649 | Standard Axle Kit <i>(Choose 8 Tires cannot use stubble proof tires)</i> | 7,105.00 | 4,831.40 |
| C502-644 | Walking Axle Kit <i>(Choose 8 Tires cannot use stubble proof tires)</i> | 6,378.00 | 4,337.04 |
| C502-648 | 618 Walking Axle Kit <i>(Choose 8 tires Stubble proof only)</i> | 6,972.00 | 4,740.96 |

~ ~ Selection 6 ~ Choose Tire Kit ~ ~

| | | Retail Price/Tire | Contract Price/Tire |
|-------------------|---|-------------------|---------------------|
| 210-182WG | Aircraft Tire <i>(Choose quantity of tires needed 6 or 8)</i> | 524.00 | 356.32 |
| 210-182FWG | Foam Filled Aircraft Tire <i>(Choose quantity of tires needed 6 or 8)</i> | 917.00 | 623.56 |
| 210-560WG | Tire Assembly Stubble Proof <i>(Choose 8 Tires)</i> | 756.00 | 514.08 |
| 210-505WG | Light Truck Tire <i>(Choose quantity of tires needed 6 or 8)</i> | 353.00 | 240.04 |

~ ~ Selection 7 ~ Schulte Fan Kit ~ ~

| | | | |
|-----------------|--|------------------|-----------------|
| C502-780 | Cyclone Fan Debris Kit, Factory Installed | 14,320.00 | 9,737.60 |
| C502-790 | Cyclone Fan Debris Kit, Crated | 14,099.00 | 9,587.32 |

~ ~ Selection 8 ~ Choose a Destination Code ~ ~

| | | | |
|----------------|---|---------------|--------------|
| C502-NA | North America and Australia Destination Kit | 120.00 | 81.60 |
|----------------|---|---------------|--------------|

~ ~ Selection 9 ~ Extra Options ~ ~

| | | | |
|-----------------|--------------------------------------|---------------|---------------|
| C502-625 | Row crop Extension Kit | 514.00 | 349.52 |
| | Assembly charge on pan units | Net | 650.00 |
| | Assembly charge on fixed blade units | Net | 750.00 |



* Above prices subject to a 4% steel tariff surcharge

MASTER PRICE SHEET



Schulte Industries Ltd.

100 John Schulte Dr., Englefeld, SK. Canada, S0K 1N0
 Tel: 306-287-3715 Fax: 306-287-3355 Toll Free: 1-800-404-6044
 Web: www.Schulte.ca



Sourcewell - Road Right Of Way Maintenance Equipment

MACHINE PRICES AND SPECIFICATIONS

5024 Rotary Cutter

CUTTER FEATURES

- 10GA deck
- Phasing cylinders (3) c/w hoses
- Wing lift cylinders (2) c/w hoses
- Suspension for center and wings
- Spring steel bushings at major pivot points
- 1000 RPM
- Deck protection rings
- S000-010 safety chain kit 1/4" grade 70 with 10,000 lbs capacity
- Two piece replaceable skid shoes
- Operator's manual in holder

~ ~ Selection 1 ~ Choose a Basic Unit ~ ~

| | | Retail Price | Contract Price |
|----|--------------------------------------|---------------------|-----------------------|
| 1) | C524-100 Basic 24' Unit, 1000 RPM | 66,636.00 | 45,312.48 |
| 2) | S000-135 Safety Light Kit (Required) | 754.00 | 512.72 |

~ ~ Selection 2 ~ Choose a Hitch Type and Accessories ~ ~

| | | | |
|----|---|-----------------|-----------------|
| 1) | C502-810 Trailing hitch, CV Style | 1,461.00 | 993.48 |
| | Choose a Clevis: | | |
| | a) C502-113WG Solid Tongue | 279.00 | 189.72 |
| | b) C502-107WG Open Clevis | 206.00 | 140.08 |
| | c) C000-300WG Precision hitch | 631.00 | 429.08 |
| | d) C502-816WG Solid Tongue with 2-3/16" hole for 2" pin | 740.00 | 503.20 |
| | e) C502-815WG Clevis with 2 3/16" Opening | 310.00 | 210.80 |
| | f) C000-360WG Adjustable Clevis | 342.00 | 232.56 |
| | Choose a Tractor Shaft: | | |
| | a) 340-8082WG CV Shaft, 1 3/4" x 20 Spline | 2,630.00 | 1,788.40 |
| | b) 340-8092WG CV Shaft, 1 3/8" x 21 Spline | 2,630.00 | 1,788.40 |
| 2) | C502-820 Trailing Equal Angle Hitch Sub Assembly | 2,528.00 | 1,719.04 |
| | Must Choose a Hitch Block | | |
| | a) C502-821 Category 3, fits up to a 1-1/2" pin and a drawbar 2-1/4" x 3-1/2" | 377.00 | 256.36 |
| | b) C502-822 Category 4, fits up to a 2" pin and a drawbar 2-1/2" x 5-1/8" | 375.00 | 255.00 |
| | Choose a Tractor Shaft: | | |
| | a) 340-5505WG Equal Angle Shaft, 1 3/8" x 21 Spline | 1,283.00 | 872.44 |
| | b) 340-5509WG Equal Angle Shaft, 1 3/4" x 20 Spline | 1,362.00 | 926.16 |

IMPORTANT: PTO Adaptor must not be used in any application.

*** Above prices subject to a 4% steel tariff surcharge**

MASTER PRICE SHEET



Schulte Industries Ltd.

100 John Schulte Dr., Englefeld, SK. Canada, S0K 1N0

Tel: 306-287-3715 Fax: 306-287-3355 Toll Free: 1-800-404-6044

Web: www.Schulte.ca



Sourcewell - Road Right Of Way Maintenance Equipment

MACHINE PRICES AND SPECIFICATIONS

5024 Rotary Cutter

~ ~ Selection 3 ~ Choose a Blade Configuration ~ ~

| | | | |
|----------|-------------------|----------|----------|
| C524-250 | Two Blade Pan Kit | 5,984.00 | 4,069.12 |
|----------|-------------------|----------|----------|

~ ~ Selection 4 ~ Choose a Safety Guard & Accessories ~ ~

| | | | |
|----------|---|----------|----------|
| C524-575 | Single Safety Chains Front & Rear c/w Front & Rear Half Belting | 3,669.00 | 2,494.92 |
|----------|---|----------|----------|

~ ~ Selection 5 ~ Choose Axle Option ~ ~

| | | | |
|----------|--|----------|----------|
| C502-643 | Standard Axle Kit <i>(Choose 6 tires cannot use stubble proof tires)</i> | 5,055.00 | 3,437.40 |
| C502-649 | Standard Axle Kit <i>(choose 8 tires cannot use stubble proof tires)</i> | 7,105.00 | 4,831.40 |
| C502-644 | Walking Axle Kit <i>(choose 8 tires cannot use stubble proof tires)</i> | 6,378.00 | 4,337.04 |
| C502-648 | 618 Walking Axle Kit <i>(Choose 8 tires Stubble proof only)</i> | 6,972.00 | 4,740.96 |

~ ~ Selection 6 ~ Choose Tire Option ~ ~

| | | | |
|------------|---|--------|--------|
| 210-182WG | Aircraft Tire <i>(Choose quantity of tires needed 6 or 8)</i> | 524.00 | 356.32 |
| 210-182FWG | Foam Filled Aircraft Tire <i>(Choose quantity of tires needed 6 or 8)</i> | 917.00 | 623.56 |
| 210-560WG | Tire Assembly Stubble Proof <i>(Choose 8 Tires)</i> | 756.00 | 514.08 |
| 210-505WG | Light Truck Tire <i>(Choose quantity of tires needed 6 or 8)</i> | 353.00 | 240.04 |

~ ~ Selection 7 ~ Schulte Fan Kit ~ ~

| | | | |
|----------|--|-----------|----------|
| C502-780 | Cyclone Fan Debris Kit, <i>Factory Installed</i> | 14,320.00 | 9,737.60 |
| C502-790 | Cyclone Fan Debris Kit, <i>Crated</i> | 14,099.00 | 9,587.32 |

* Above prices subject to a 4% steel tariff surcharge

MASTER PRICE SHEET



Schulte Industries Ltd.

100 John Schulte Dr., Englefeld, SK. Canada, S0K 1N0

Tel: 306-287-3715 Fax: 306-287-3355 Toll Free: 1-800-404-6044

Web: www.Schulte.ca



Sourcewell - Road Right Of Way Maintenance Equipment

MACHINE PRICES AND SPECIFICATIONS

5024 Rotary Cutter

~ ~ Selection 8 ~ Choose a Destination Code ~ ~

| | | | |
|---------|---|-------|-------|
| C524-NA | North America and Australia Destination Kit | 73.00 | 49.64 |
|---------|---|-------|-------|

~ ~ Selection 9 ~ Extra Options ~ ~

| | | | |
|-------------------------------------|------------------------------|------------|---------------|
| C502-920 | Crop dividers | 332.00 | 225.76 |
| C502-740 | HYD Cooler Factory Installed | 6,374.00 | 4,334.32 |
| C502-745 | HYD Cooler Factory Crated | 6,072.00 | 4,128.96 |
| C502-625 | Row Crop Extension Kit | 514.00 | 349.52 |
| Assembly charge on pan units | | Net | 650.00 |



* Above prices subject to a 4% steel tariff surcharge

MASTER PRICE SHEET



Schulte Industries Ltd.

100 John Schulte Dr., Englefeld, SK. Canada, S0K 1N0

Tel: 306-287-3715 Fax: 306-287-3355 Toll Free: 1-800-404-6044

Web: www.Schulte.ca



Sourcewell - Road Right Of Way Maintenance Equipment

MACHINE PRICES AND SPECIFICATIONS

FX-520 Rotary Cutter

SPECIFICATIONS

- | | | |
|---|---|--|
| - Overall Width --- 247" (6.2m) | - Transport Width --- 91" (2.32m) | - Min. Tractor Size --- 100hp (75kw) |
| - Overall Length --- 242" (6.15m) | - Transport Height --- 120" (3.05m) | - Blade Tip Speed --- 16,000 ft/min |
| - Cutting Height --- 2" - 17.5" (Depending on Tire Size) | - Cutting Capacity --- 2" (51mm) 2" (51mm) Fixed Knife | - Blade Overlap --- 6" (153mm) |
| - Cutting Width --- 240" (6.10m) | 4" (102 mm) Pan Unit | - Deck Thickness --- 180" (7 ga) (4.6mm) |

~ ~ Selection 1 ~ Choose a Basic Unit ~ ~

| | | <i>Retail Price</i> | <i>Contract Price</i> |
|----|--------------------------------------|---------------------|-----------------------|
| 1) | C520-100 Basic 20' Unit, 1000 RPM | 55,096.00 | 37,465.28 |
| 2) | S000-080 Safety Light Kit (Required) | 698.00 | 474.64 |

~ ~ Selection 2 ~ Choose a Hitch Type and Accessories ~ ~

| | | | |
|----|--|----------|----------|
| 2) | C520-800 Trailing hitch, CV Style | 1,391.00 | 945.88 |
| | Choose a Clevis: | | |
| a) | C000-513WG Solid Tongue | 558.00 | 379.44 |
| b) | C000-507WG Open Clevis | 520.00 | 353.60 |
| c) | C000-500WG Precision hitch | 860.00 | 584.80 |
| d) | C000-516WG Solid Tongue with 2-3/16" hole for 2" pin | 995.00 | 676.60 |
| e) | C000-515WG Clevis with 2 3/16" Opening | 600.00 | 408.00 |
| f) | C000-510WG Pro Level Hitch | 776.00 | 527.68 |
| | Choose a Tractor Shaft: | | |
| a) | 340-8092WG CV Shaft, 1 3/8" x 21 Spline | 2,630.00 | 1,788.40 |
| b) | 340-8082WG CV Shaft, 1 3/4" x 20 Spline | 2,630.00 | 1,788.40 |

* Above prices subject to a 4% steel tariff surcharge

MASTER PRICE SHEET



Schulte Industries Ltd.

100 John Schulte Dr., Englefeld, SK. Canada, S0K 1N0

Tel: 306-287-3715 Fax: 306-287-3355 Toll Free: 1-800-404-6044

Web: www.Schulte.ca



Sourcewell - Road Right Of Way Maintenance Equipment

MACHINE PRICES AND SPECIFICATIONS

FX-520 Rotary Cutter

~ ~ Selection 3 ~ Choose a Blade Configuration ~ ~

| | | | | |
|----|----------|---|----------|----------|
| 1) | C520-250 | Pan Kit with Updraft Blades and Shrouds | 4,905.00 | 3,335.40 |
| 2) | C520-260 | Pan Kit with Shredder Blades and Shrouds | 5,879.00 | 3,997.72 |
| 3) | C520-265 | Fixed Knife Shredder Kit with Updraft Blades & Shrouds | 7,475.00 | 5,083.00 |
| 4) | C520-295 | Fixed Knife Kit with Flat Blades & Shrouds (For Cotton) | 7,235.00 | 4,919.80 |

~ ~ Selection 4 ~ Choose a Safety Guard and Accessories ~ ~

| | | | | |
|----|----------|---|----------|----------|
| 1) | C520-500 | Single chains front and rear | 1,955.00 | 1,329.40 |
| 2) | C520-550 | Double chains front and rear | 2,445.00 | 1,662.60 |
| | a) | C520-580 Half Length Front Belting <i>(Must be used with a chain option)</i> | 675.00 | 459.00 |

~ ~ Selection 5 ~ Choose Axle and Tire Option ~ ~

| | | | | |
|----|----------|--|----------|----------|
| 1) | C520-612 | Standard 618 Axle kit <i>(Choose 4 Tires - Stubble Proof Only)</i> | 5,382.00 | 3,659.76 |
| 2) | C520-614 | 517 Axle Kit c/w Center duals <i>(choose 6 Tires)</i> | 5,569.00 | 3,786.92 |
| 3) | C520-616 | 517 Axle Kit c/w Center Walking <i>(choose 6 Tires)</i> | 6,021.00 | 4,094.28 |
| 4) | C520-618 | 517 Dual Axle Kit <i>(Choose 8 Tires)</i> | 6,295.00 | 4,280.60 |
| 5) | C520-622 | 517 Walking Axle kit <i>(Choose 8 Tires)</i> | 7,270.00 | 4,943.60 |
| 6) | C520-624 | 517 Center Walking Axle c/w Duals on Wings <i>(Choose 8 Tires)</i> | 6,731.00 | 4,577.08 |

~ ~ Selection 6 ~ Choose Axle and Tire Option ~ ~

| | | | Retail Price/Tire | Contract Price/Tire |
|-----|------------|--|-------------------|---------------------|
| 7) | 210-560WG | Tire Assembly Stubble Proof <i>(Can only be used with C520-612)</i> | 756.00 | 514.08 |
| 8) | 210-182WG | Aircraft Tire <i>(Choose quantity of tires needed, 6 or 8)</i> | 524.00 | 356.32 |
| 9) | 210-182FWG | Foam Filled Aircraft Tire <i>(Choose quantity of tires needed, 6 or 8)</i> | 917.00 | 623.56 |
| 10) | 210-505WG | Light Truck Tire <i>(Choose quantity of tires needed, 6 or 8)</i> | 353.00 | 240.04 |

* Above prices subject to a 4% steel tariff surcharge

MASTER PRICE SHEET



Schulte Industries Ltd.

100 John Schulte Dr., Englefeld, SK. Canada, S0K 1N0

Tel: 306-287-3715 Fax: 306-287-3355 Toll Free: 1-800-404-6044

Web: www.Schulte.ca



Sourcewell - Road Right Of Way Maintenance Equipment

MACHINE PRICES AND SPECIFICATIONS

FX-520 Rotary Cutter

~ ~ **Selection 7 ~ Choose a Destination Code** ~ ~

| | | | | |
|----|---------|---|-------|-------|
| 1) | C520-NA | North America and Australia Destination Kit | 95.00 | 64.60 |
|----|---------|---|-------|-------|

| | | | |
|--|------------------------------|-----|--------|
| | Assembly charge on pan units | Net | 650.00 |
|--|------------------------------|-----|--------|

| | | | |
|--|--------------------------------------|-----|--------|
| | Assembly charge on fixed blade units | Net | 750.00 |
|--|--------------------------------------|-----|--------|



* Above prices subject to a 4% steel tariff surcharge

MASTER PRICE SHEET



Schulte Industries Ltd.

100 John Schulte Dr., Englefeld, SK. Canada, S0K 1N0

Tel: 306-287-3715 Fax: 306-287-3355 Toll Free: 1-800-404-6044

Web: www.Schulte.ca



Sourcewell - Road Right Of Way Maintenance Equipment

MACHINE PRICES AND SPECIFICATIONS

FX-320 Pan & Fixed Knife Rotary Cutter

SPECIFICATIONS

| | | |
|---|---|--|
| - Overall Width --- 249" (6.32m) | - Transport Width --- 98" (2.49m) | - Min. Tractor Size --- 100hp (75kw) |
| - Overall Length --- 242" (6.15m) | - Transport Height --- 100" (2.55m) | - Blade Tip Speed --- 16,031 ft/min (540 RPM) |
| - Cutting Height --- 2" - 19.5" (Depending on Tire Size) | - Cutting Capacity --- 2" (51mm) 2" (51mm) Fixed Knife | - Blade Tip Speed --- 16,289 ft/min (1000 RPM) |
| - Cutting Width --- 240" (6.10m) | 4" (102 mm) Pan Unit | - Blade Overlap --- 6" (153mm) |
| | | - Deck Thickness --- .180" (7 ga) (4.6mm) |

~ ~ Selection 1 ~ Choose a Basic Unit ~ ~

| | | <i>Retail Price</i> | <i>Contract Price</i> |
|----|---|---------------------|-----------------------|
| 1) | C321-100 FX320 Base Unit | 33,848.00 | 23,016.64 |
| 2) | S000-170 Safety Light Kit (Required) | 892.00 | 606.56 |
| | Choose a Drive Package: | | |
| a) | C321-700 Drive Package, CW Center, 540 RPM | 8,440.00 | 5,739.20 |
| b) | C321-705 Drive Package, CW Center, 1000 RPM | 8,440.00 | 5,739.20 |
| | Choose Independent Wing Lift: | | |
| a) | C321-310 Independent Wing Lift Kit (Required) | 225.00 | 153.00 |

~ ~ Selection 2 ~ Choose a Hitch Type and Accessories ~ ~

| | | | |
|----|--|-----------------|-----------------|
| 1) | C185-180 Trailing hitch, CV Style | 997.00 | 677.96 |
| | Choose a Clevis: | | |
| a) | C000-513WG Solid Tongue | 558.00 | 379.44 |
| b) | C000-507WG Open Clevis | 520.00 | 353.60 |
| c) | C000-500WG Precision hitch | 860.00 | 584.80 |
| d) | C000-516WG Solid Tongue with 2-3/16" hole for 2" pin | 995.00 | 676.60 |
| e) | C000-515WG Clevis with 2 3/16" Opening | 600.00 | 408.00 |
| f) | C000-510WG Pro Level Hitch | 776.00 | 527.68 |
| | Choose a Tractor Shaft: | | |
| a) | 340-870WG CV Shaft, 540 RPM | 1,880.00 | 1,278.40 |
| b) | 340-648WG CV Shaft, 1000 RPM | 1,557.00 | 1,058.76 |
| c) | 340-658WG CV Shaft 1000 RPM 1 3/4" shaft | 2,050.00 | 1,394.00 |
| 2) | C185-196 Equal Angle Hitch Kit w/ 540 RPM Shaft c/w Non CV Drive Shaft | 3,180.00 | 2,162.40 |

* Above prices subject to a 4% steel tariff surcharge

MASTER PRICE SHEET



Schulte Industries Ltd.

100 John Schulte Dr., Englefeld, SK. Canada, S0K 1N0

Tel: 306-287-3715 Fax: 306-287-3355 Toll Free: 1-800-404-6044

Web: www.Schulte.ca



Sourcewell - Road Right Of Way Maintenance Equipment

MACHINE PRICES AND SPECIFICATIONS

FX-320 Pan & Fixed Knife Rotary Cutter

~ ~ Selection 3 ~ Choose a Blade Configuration ~ ~

| | | | | |
|----|----------|---|----------|----------|
| 1) | C321-450 | Pan Kit, 4" Blades | 4,400.00 | 2,992.00 |
| 2) | C321-455 | Pan Kit, 5" Blades | 4,432.00 | 3,013.76 |
| 3) | C321-475 | Fixed Knives Only <i>(Select Shrouding Kit Listed Below w/ Fixed Knife Kit)</i> | 4,220.00 | 2,869.60 |
| 4) | C321-480 | Shrouding Kit <i>(Shrouds only)</i> | 792.00 | 538.56 |

~ ~ Selection 4 ~ Choose a Safety Guard and Accessories ~ ~

| | | | | |
|----|----------|-----------------------------------|----------|----------|
| 1) | C321-500 | Single Safety Chains Front & Rear | 2,200.00 | 1,496.00 |
| 2) | C321-510 | Double Safety Chains Front & Rear | 2,450.00 | 1,666.00 |
| 3) | C321-550 | Front Half Belting | 831.00 | 565.08 |
| 4) | C321-560 | Rear Half Belting | 819.00 | 556.92 |

~ ~ Selection 5 ~ Choose Axle and Tire Option ~ ~

Choose a Walking Axle Configuration, or Move down to Non Walking

| | | | | |
|---|----------|---|----------|----------|
| 1) | C350-820 | Walking Axle Mounts <i>(4 tire kit, axles included)</i> | 2,337.00 | 1,589.16 |
| Choose 2 if wanting center & wings both walking, or choose 1 if you are wanting only center walking axles | | | | |

| | | | | |
|----|----------|---|----------|--------|
| 2) | C350-830 | Non Walking Wing Axles <i>(2 Tire Kit, Axles Included)</i> | 969.00 | 658.92 |
| 3) | C350-825 | Non Walking Wing Axles <i>(4 Tire Kit, Axles Included)</i> | 1,372.00 | 932.96 |

Or Choose a non walking axle kit below

| | | | | |
|----|----------|---|----------|----------|
| 4) | C321-865 | Non Walking Wheel Standards - 8 Tires <i>(517 Hub - Center & Wings)</i> | 2,745.00 | 1,866.60 |
| 5) | C321-870 | Non Walking Wheel Standards - 6 Tires <i>(517 Hub - Center & Wings)</i> | 2,400.00 | 1,632.00 |
| 6) | C321-875 | Non Walking Wheel Standards - 4 Tires <i>(618 Hub - Center & Wings)</i> | 2,400.00 | 1,632.00 |

~ ~ Selection 6 ~ Choose Axle and Tire Option ~ ~

| | | | Retail Price/Tire | Contract Price/Tire |
|----|------------|---|-------------------|---------------------|
| 1) | 210-560WG | Tire Assembly Stubble Proof <i>(Can only be used with C321-875)</i> | 756.00 | 514.08 |
| 2) | 210-540WG | Tire 24x8-14 20 Ply Rated Severe Duty | 519.00 | 352.92 |
| 3) | 210-540FWG | Tire 24x8-14 20 Ply Rated Severe Duty Foam Filled | 825.00 | 561.00 |
| 4) | 210-505WG | Light Truck Tire (ST205/90D-15/8 Ply) | 353.00 | 240.04 |
| 5) | 210-192WG | Solid Laminated Tire, 6 x 9 x 26 | 509.00 | 346.12 |

* Above prices subject to a 4% steel tariff surcharge

MASTER PRICE SHEET



Schulte Industries Ltd.

100 John Schulte Dr., Englefeld, SK. Canada, S0K 1N0

Tel: 306-287-3715 Fax: 306-287-3355 Toll Free: 1-800-404-6044

Web: www.Schulte.ca



Sourcewell - Road Right Of Way Maintenance Equipment

MACHINE PRICES AND SPECIFICATIONS

FX-320 Pan & Fixed Knife

Rotary Cutter

~ ~ **Selection 7 ~ Choose a Destination Code** ~ ~

| | | | | |
|----|---------|---|---------------|---------------|
| 1) | C321-NA | North America and Australia Destination Kit | 105.00 | 71.40 |
| | | Assembly charge on pan units | Net | 400.00 |
| | | Assembly charge on fixed blade units | Net | 500.00 |



* Above prices subject to a 4% steel tariff surcharge

MASTER PRICE SHEET



Schulte Industries Ltd.

100 John Schulte Dr., Englefeld, SK. Canada, S0K 1N0

Tel: 306-287-3715 Fax: 306-287-3355 Toll Free: 1-800-404-6044

Web: www.Schulte.ca



Sourcewell - Road Right Of Way Maintenance Equipment

MACHINE PRICES AND SPECIFICATIONS

FX-318 Rotary Cutter (Pan Unit)

CUTTER FEATURES

- 540/1000 RPM 80° CV Drive
- 540 Equal angle non cv drive
- 7 ga Single Domed Deck and Stump Jumpers
- Rubber 3 Puck Grommet Suspension
- Cutting Height
- 90 HP Recommended Tractor
- Cutting Width 216" (5.5m)
- wings) 96"(2.4m)
- Replaceable Skid Shoes
- Height Control Cylinder & Hoses
- Wing Lift Cylinders & Hoses
- 1.75" to 16.75" (44.5mm to 425mm)
- Over Center Folding Wings
- Transport Width (max with duals on

~ ~ Selection 1 ~ Choose a Basic Unit, Drive Package ~ ~

| | | Retail Price | Contract Price |
|-------------------------|---|--------------|----------------|
| C318-100 | Schulte FX-318, Basic Unit | 25,725.00 | 17,493.00 |
| S000-085 | Safety Light Kit (Required) | 673.00 | 457.64 |
| Choose a Drive Package: | | | |
| a) | C318-735 Drive Package, CW Center, 540 RPM | 7,880.00 | 5,358.40 |
| b) | C318-720 Drive Package, CW Center, 1000 RPM | 7,880.00 | 5,358.40 |

~ ~ Selection 2 ~ Trailing Hitch ~ ~

Note: It using Equal Angle Hitch Skip to Selection 3

| | | | |
|--------------------|--|----------|----------|
| C185-180 | Trailing Hitch, CV Style (Required) | 997.00 | 677.96 |
| Choose a CV Shaft: | | | |
| a) | 340-870WG CV Shaft, 540 RPM | 1,880.00 | 1,278.40 |
| b) | 340-648WG CV Shaft, 1000 RPM | 1,557.00 | 1,058.76 |
| c) | 340-658WG CV Shaft 1000 RPM 1 3/4" shaft | 2,050.00 | 1,394.00 |
| Choose a Clevis: | | | |
| C000-506WG | Open Clevis (Minimum Requirments) | 475.00 | 323.00 |
| C000-500WG | Precision hitch | 860.00 | 584.80 |
| C000-513WG | Solid Tongue | 558.00 | 379.44 |
| C000-510WG | Pro Level Hitch | 776.00 | 527.68 |

~ ~ Selection 3 ~ Equal Angle Clevis ~ ~

| | | | |
|----------|---|----------|----------|
| C185-196 | Equal Angle Hitch Kit w/ 540 RPM Shaft c/w Non CV Drive Shaft | 3,180.00 | 2,162.40 |
|----------|---|----------|----------|

* Above prices subject to a 4% steel tariff surcharge

MASTER PRICE SHEET



Schulte Industries Ltd.

100 John Schulte Dr., Englefeld, SK. Canada, S0K 1N0

Tel: 306-287-3715 Fax: 306-287-3355 Toll Free: 1-800-404-6044

Web: www.Schulte.ca



Sourcewell - Road Right Of Way Maintenance Equipment

MACHINE PRICES AND SPECIFICATIONS

FX-318 Rotary Cutter (Pan Unit)

~ ~ Selection 4 ~ Choose a Chain Guards ~ ~

| | | | |
|----------|--|----------|----------|
| C318-500 | Chain Guards Single Front and Rear | 1,837.00 | 1,249.16 |
| C318-550 | Chain Guards Double Front and Rear | 2,258.00 | 1,535.44 |
| C318-560 | Front Half Belting <i>(Must be used with a chain option)</i> | 685.00 | 465.80 |
| C318-570 | Rear Half Belting <i>(Must be used with a chain option)</i> | 650.00 | 442.00 |

~ ~ Selection 5 ~ Choose a Pan Kit ~ ~

| | | | |
|----------|--------------------|----------|----------|
| C318-450 | Pan Kit (required) | 2,799.00 | 1,903.32 |
|----------|--------------------|----------|----------|

~ ~ Selection 6 ~ Choose a Blade Configuration ~ ~

| | | | |
|----------|--|----------|--------|
| C318-460 | Updraft Blades, CW Center | 693.00 | 471.24 |
| C318-465 | Super Updraft 5" Blades CW Center | 808.00 | 549.44 |
| C318-470 | Shredder Blades, CW Center <i>(optional)</i> | 1,135.00 | 771.80 |

~ ~ Selection 7 ~ Choose Both Wheel Standard Kits ~ ~

| | | | |
|----------|---|----------|--------|
| C318-810 | Wing Wheel Standard, 1 or 2 Tires <i>Required</i> | 1,210.00 | 822.80 |
| C318-800 | Dual Wheel Standard on the Center <i>Required</i> | 1,440.00 | 979.20 |

~ ~ Selection 8 ~ Choose a Axle Kit ~ ~

| | | | |
|----------|----------------------|----------|----------|
| C180-484 | Axle Kit for 4 Tires | 869.00 | 590.92 |
| C180-486 | Axle Kit for 6 Tires | 1,388.00 | 943.84 |
| C180-488 | Axle Kit for 8 Tires | 1,977.00 | 1,344.36 |

~ ~ Selection 9 ~ Choose a Tire Option ~ ~

Please state the quantity of tires that you would like to order as the numbers listed below are single tires and not tire kits.

| | | Retail Price/Tire | Contract Price/Tire |
|------------|---|-------------------|---------------------|
| 210-003WG | Solid Laminated Tires, 6 x 9 x 20 | 316.00 | 214.88 |
| 210-175WG | Forklift Tire 6.5 x 10 - 12 ply on 2 pce 5 bolt rim | 445.00 | 302.60 |
| 210-175FWG | Foam Filled Forklift Tire 6.5 x 10 - 12 ply on 2 pce 5 bolt rim | 776.00 | 527.68 |
| 210-540WG | Tire 24x8-14 20 Ply Rated Severe Duty | 519.00 | 352.92 |
| 210-540FWG | Tire 24x8-14 20 Ply Rated Severe Duty Foam Filled | 825.00 | 561.00 |
| 210-192WG | Solid Laminated Tire, 6 x 9 x 26 | 509.00 | 346.12 |

* Above prices subject to a 4% steel tariff surcharge

MASTER PRICE SHEET



Schulte Industries Ltd.

100 John Schulte Dr., Englefeld, SK. Canada, S0K 1N0

Tel: 306-287-3715 Fax: 306-287-3355 Toll Free: 1-800-404-6044

Web: www.Schulte.ca



Sourcewell - Road Right Of Way Maintenance Equipment

MACHINE PRICES AND SPECIFICATIONS

FX-318 Rotary Cutter (Pan Unit)

~ ~ Selection 10 ~ Choose a Destination Code ~ ~

| | | | |
|---------|---------------------------------------|-------|-------|
| C318-NA | North American & Australian Decal Kit | 66.00 | 44.88 |
|---------|---------------------------------------|-------|-------|

~ ~ Selection 11 ~ Choose Extra Options ~ ~

| | | | |
|----------|--|-----------------|------------------|
| C185-310 | Independent Wing Lift | 225.00 | 153.00 |
| C000-620 | Toolbox Mount & Toolbox Assembly Charge | 1,285.00 Net | 873.80 400.00 |



* Above prices subject to a 4% steel tariff surcharge

MASTER PRICE SHEET



Schulte Industries Ltd.

100 John Schulte Dr., Englefeld, SK. Canada, S0K 1N0

Tel: 306-287-3715 Fax: 306-287-3355 Toll Free: 1-800-404-6044

Web: www.Schulte.ca



Sourcewell - Road Right Of Way Maintenance Equipment

MACHINE PRICES AND SPECIFICATIONS

FX-212 Rotary Cutter

CUTTER FEATURES

- 540/1000 RPM 80° CV Drive
- 540 Equal angle non cv drive
- 7 ga Single Domed Deck and Stump Jumpers
- Rubber 3 Puck Grommet Suspension
- 90 HP Recommended Tractor
- Cutting Width 144-1/2" (3.65m)
- Replaceable Skid Shoes
- Height Control Cylinder & Hoses
- Wing Lift Cylinders & Hoses
- 1.75" to 16.75" (44.5mm to 425mm) Cutting Height
- Over Center Folding Wings
- Transport Width 87"(2.4m)

~ ~ Selection 1 ~ Choose a Basic Unit, Drive Package ~ ~

| | | Retail Price | Contract Price |
|-----------------------------------|--|--------------|----------------|
| C319-100 | FX-212, Basic Unit | 23,806.00 | 16,188.08 |
| S000-085 | Safety Light Kit (Required) | 673.00 | 457.64 |
| <i>DRIVE PACKAGE (choose one)</i> | | | |
| C319-735 | CW Rotation on Center, 540 RPM G8 Shaft | 5,450.00 | 3,706.00 |
| C319-720 | CW Rotation on Center, 1000 RPM G8 Shaft | 5,450.00 | 3,706.00 |

~ ~ Selection 2 ~ Choose a Hitch Option ~ ~

| | | | |
|--------------------|--|----------|----------|
| C185-180 | Trailing Hitch, CV Style | 997.00 | 677.96 |
| Choose a CV Shaft: | | | |
| a) 340-870WG | CV Shaft, 540 RPM | 1,880.00 | 1,278.40 |
| b) 340-648WG | CV Shaft, 1000 RPM | 1,557.00 | 1,058.76 |
| C185-196 | Equal Angle Hitch Kit w/ 540 RPM Shaft | 3,180.00 | 2,162.40 |

~ ~ Selection 3 ~ Choose a Clevis ~ ~

| | | | |
|------------|-----------------------------------|--------|--------|
| C000-506WG | Open Clevis (Minimum Requirments) | 475.00 | 323.00 |
| C000-500WG | Precision hitch | 860.00 | 584.80 |
| C000-510WG | Pro Level Hitch | 776.00 | 527.68 |
| C000-513WG | Solid Tongue | 558.00 | 379.44 |

~ ~ Selection 4 ~ Choose Axle Kits ~ ~

| | | | |
|----------|---|----------|--------|
| C319-810 | Single Axle Kit for Right Wing (Required) (accomodates 1 or 2 tires) | 469.00 | 318.92 |
| C318-800 | Duals Wheel Standard on Center (Required) | 1,440.00 | 979.20 |

PREDELIVERY SERVICE IS REQUIRED BY DEALER OR END USER

* Above prices subject to a 4% steel tariff surcharge

MASTER PRICE SHEET



Schulte Industries Ltd.

100 John Schulte Dr., Englefeld, SK. Canada, S0K 1N0

Tel: 306-287-3715 Fax: 306-287-3355 Toll Free: 1-800-404-6044

Web: www.Schulte.ca



Sourcewell - Road Right Of Way Maintenance Equipment

MACHINE PRICES AND SPECIFICATIONS

FX-212 Rotary Cutter

~ ~ Selection 5 ~ Choose a Safety Guard ~ ~

| | | | |
|----------|----------------------------------|----------|--------|
| C319-500 | Chain Guards Single Front & Rear | 1,048.00 | 712.64 |
| C319-550 | Chain Guards Double Front & Rear | 1,376.00 | 935.68 |
| C319-560 | Front Half Belting | 480.00 | 326.40 |
| C319-570 | Rear Half Belting | 433.00 | 294.44 |

~ ~ Selection 6 ~ Choose The Pan Kit ~ ~

| | | | |
|----------|--------------------|----------|----------|
| C319-450 | Pan Kit (required) | 1,764.00 | 1,199.52 |
|----------|--------------------|----------|----------|

~ ~ Selection 7 ~ Choose a Blade Configuration ~ ~

| | | | |
|----------|---------------------------|--------|--------|
| C319-460 | Updraft Blades, CW Center | 455.00 | 309.40 |
|----------|---------------------------|--------|--------|

~ ~ Selection 8 ~ Choose an Axle Kit ~ ~

| | | | |
|----------|----------------------|----------|--------|
| C190-485 | Axle Kit for 5 Tires | 1,182.00 | 803.76 |
| C180-486 | Axle Kit for 6 Tires | 1,388.00 | 943.84 |

~ ~ Selection 9 ~ Choose a Tire Option ~ ~

Please state the quantity of tires that you would like to order as the numbers listed below are single tires and not tire kits.

| | | | |
|------------|---|--------|--------|
| 210-003WG | Solid Laminated Tires, 6 x 9 x 20 | 316.00 | 214.88 |
| 210-175WG | Tire Assy, Forklift, 6.5 x 10 - 12 ply on 2 pce 5 bolt rim | 445.00 | 302.60 |
| 210-175FWG | Foam Filled Forklift Tire 6.5 x 10 - 12 ply on 2 pce 5 bolt rim | 776.00 | 527.68 |
| 210-540WG | Tire 24x8-14 20 Ply Rated Severe Duty | 519.00 | 352.92 |
| 210-540FWG | Tire 24x8-14 20 Ply Rated Severe Duty Foam Filled | 825.00 | 561.00 |
| 210-192WG | Solid Laminated Tire, 6 x 9 x 26 | 509.00 | 346.12 |

~ ~ Selection 10 ~ Choose a Destination Code ~ ~

| | | | |
|---------|---------------------------------------|------------|---------------|
| C319-NA | North American & Australian Decal Kit | 63.00 | 42.84 |
| | Assembly Charge | Net | 300.00 |

PREDELIVERY SERVICE IS REQUIRED BY DEALER OR END USER



* Above prices subject to a 4% steel tariff surcharge

MASTER PRICE SHEET



Schulte Industries Ltd.

100 John Schulte Dr., Englefeld, SK. Canada, S0K 1N0

Tel: 306-287-3715 Fax: 306-287-3355 Toll Free: 1-800-404-6044

Web: www.Schulte.ca



Sourcewell - Road Right Of Way Maintenance Equipment

MACHINE PRICES AND SPECIFICATIONS

TPX-318 3PT FOLDING FLEX WING

CUTTER FEATURES

- 1000 RPM CV Drive
- Heavy duty rubber coupler on drive line
- Fold up design for narrow transport width
- Greasable bushings
- Easy height adjustment
- Double acting wings
- Only one hydraulic circuit needed
- 2" to 17" Cutting Height

~ ~ Selection 1 ~ Choose a Basic Unit, Drive Package ~ ~

| | | Retail Price | Contract Price |
|----------|---|--------------|----------------|
| C380-100 | TPX-318 Base Unit c/w Fixed Knife Mulching System (Cotton, Corn, Sugar Cane Stalks) | 38,827.00 | 26,402.36 |

~ ~ Selection 2 ~ Choose a Tractor Shaft ~ ~

| | | | |
|-----------|----------------------|----------|----------|
| 340-829WG | CV Shaft, 1-3/8" Z21 | 2,055.00 | 1,397.40 |
| 340-833WG | CV Shaft, 1-3/4" Z20 | 2,055.00 | 1,397.40 |

~ ~ Selection 3 ~ Choose a Blade Option ~ ~

| | | | |
|----------|----------------------------------|--------|--------|
| C380-400 | Blades, Schulte Standard Updraft | 976.00 | 663.68 |
|----------|----------------------------------|--------|--------|

~ ~ Selection 4 ~ Choose a Belting Option ~ ~

| | | | |
|----------|-----------------------|--------|--------|
| C380-530 | TPX-318 Front Belting | 585.00 | 397.80 |
| C380-540 | TPX-318 Rear Belting | 585.00 | 397.80 |

~ ~ Selection 5 ~ Choose an Axle Style ~ ~

| | | | |
|----------|----------------------------|----------|----------|
| C380-480 | TPX318 Solid Wheel Option | 1,954.00 | 1,328.72 |
| C380-485 | TPX318 Castor Wheel Option | 3,840.00 | 2,611.20 |

~ ~ Selection 6 ~ Choose an Tire Option ~ ~

(CHOOSE 4 TIRES PER UNIT, 2 LEFT & 2 RIGHT)

| | | | |
|-----------|--|--------|--------|
| 210-186WG | 27 X 10.5-15 Skid Steer Tire, LEFT | 492.00 | 334.56 |
| 210-187WG | 27 X 10.5-15 Skid Steer Tire, RIGHT | 492.00 | 334.56 |

~ ~ Selection 7 ~ Choose a Destination Code ~ ~

| | | | |
|---------|---------------------------------------|-------|--------|
| C380-NA | North American & Australian Decal Kit | 70.00 | 47.60 |
| | Assembly Charge | Net | 400.00 |

PREDELIVERY SERVICE IS REQUIRED BY DEALER OR END USER



* Above prices subject to a 4% steel tariff surcharge

MASTER PRICE SHEET



Schulte Industries Ltd.

100 John Schulte Dr., Englefeld, SK. Canada, S0K 1N0

Tel: 306-287-3715 Fax: 306-287-3355 Toll Free: 1-800-404-6044

Web: www.Schulte.ca



Sourcewell - Road Right Of Way Maintenance Equipment

MACHINE PRICES AND SPECIFICATIONS

XH1500 Series 5 Rotary Cutter

CUTTER FEATURES

- 7GA deck
- Replaceable skid shoes
- Double safety chains front & rear
- Hydraulic phasing lift system
- Hydraulic wing lift system
- 517 Hubs and axles
- Single domed, sweep clean deck
- Rubber suspension - standard
- Four gearbox drive layout
- 240hp down, 275hp splitter
- Full floating front hitch
- Deck protection rings
- S000-010 safety chain kit 1/4" grade 70 with 10,000 lbs capacity
- 1/4" Round skid pans (Stump Jumpers)
- Pentagon blade bolt design
- Operator's manual in holder

~ ~ Selection 1 ~ Choose a Basic Unit ~ ~

| | Retail Price | Contract Price |
|---|--------------|----------------|
| 1) C350-100 <i>Basic Unit XH Series 5</i> | 23,663.00 | 16,090.84 |
| 2) C350-200 <i>15' Option (Required)</i> | 18,234.00 | 12,399.12 |
| 3) S000-160 <i>Safety Light Kit (Required)</i> | 876.00 | 595.68 |
| 4) C301-830 <i>ISO Couplers (Required)</i> | 79.00 | 53.72 |
| <i>Choose a Drive Package:</i> | | |
| a) C350-705 <i>CW Rotation Center 540 RPM (Std. Rotation)</i> | 7,695.00 | 5,232.60 |
| b) C350-715 <i>CW Rotation Center 1000 RPM (Std. Rotation)</i> | 7,695.00 | 5,232.60 |
| c) C350-700 <i>OR CCW Rotation on Center 540 RPM (Non Std Rotation)</i> | 7,695.00 | 5,232.60 |
| d) C350-710 <i>OR CCW Rotation on Center 1000 RPM (Non Std. Rotation)</i> | 7,695.00 | 5,232.60 |

~ ~ Selection 2 ~ Choose a Hitch Type and Accessories ~ ~

| | | |
|---|----------|----------|
| 1) C350-180 <i>Trailing Hitch CV Style</i> | 1,096.00 | 745.28 |
| <i>Choose a Clevis:</i> | | |
| a) C000-506WG <i>Open Clevis (Minimum Requirement with a Flex Arm)</i> | 475.00 | 323.00 |
| b) C000-500WG <i>Precision Hitch (Can be used with a Flex Arm)</i> | 860.00 | 584.80 |
| c) C000-513WG <i>Solid tongue (Can be used with a Flex Arm)</i> | 558.00 | 379.44 |
| d) C000-515WG <i>Clevis 2 3/16 " opening (Can be used with a Flex Arm)</i> | 600.00 | 408.00 |
| e) C000-510WG <i>Pro Level Hitch (Can <u>NOT</u> be used with a Flex Arm)</i> | 776.00 | 527.68 |
| <i>Choose a Tractor Shaft:</i> | | |
| a) 340-870WG <i>CV Shaft, 540 rpm</i> | 1,880.00 | 1,278.40 |
| b) 340-648WG <i>CV Shaft, 1000 rpm</i> | 1,557.00 | 1,058.76 |
| c) 340-658WG <i>CV Shaft 1000 RPM 1 3/4" shaft</i> | 2,050.00 | 1,394.00 |
| 2) C350-196 <i>Equal Angle Hitch Kit w/ 540 RPM Shaft</i> | 3,382.00 | 2,299.76 |

~ ~ Selection 3 ~ Choose Hydraulic Option ~ ~

| | | |
|--|--------|--------|
| 1) C350-805 <i>Independent Double Acting Hose Kit OR</i> | 415.00 | 282.20 |
| 2) C350-810 <i>Double Acting Hose Kit</i> | 374.00 | 254.32 |

*** Above prices subject to a 4% steel tariff surcharge**

MASTER PRICE SHEET



Schulte Industries Ltd.

100 John Schulte Dr., Englefeld, SK. Canada, S0K 1N0

Tel: 306-287-3715 Fax: 306-287-3355 Toll Free: 1-800-404-6044

Web: www.Schulte.ca



Sourcewell - Road Right Of Way Maintenance Equipment

MACHINE PRICES AND SPECIFICATIONS

XH1500 Series 5 Rotary Cutter

~ ~ Selection 4 ~ Choose a Blade Configuration ~ ~

| | | | | |
|----|----------|---|--------|--------|
| 1) | C350-450 | 2 Blade Pan Kit - cw Schulte Super Suction Updraft 4" Blades | 465.00 | 316.20 |
| 2) | C350-451 | 2 Blade Pan Kit - ccw Schulte Super Suction Updraft 4" Blades | 465.00 | 316.20 |
| 3) | C350-455 | 2 Blade Pan Kit - cw Schulte Super Suction Updraft 5" Blades | 555.00 | 377.40 |
| 4) | C350-456 | 2 Blade Pan Kit - ccw Schulte Super Suction Updraft 5" Blades | 555.00 | 377.40 |

~ ~ Selection 5 ~ Choose a Center Axle Kit ~ ~

| | | | | |
|----|----------|---|----------|----------|
| 1) | C350-820 | Walking (Axles Included) | 2,337.00 | 1,589.16 |
| 2) | C350-825 | Non Walking (4 Tire Kit, Axles Included) | 1,372.00 | 932.96 |
| 3) | C350-350 | Large Tire Option - Center Section (2 Tires) | 3,651.00 | 2,482.68 |

C350-350 Includes mounts & tires - Only select tires for the wing axle option

~ ~ Selection 6 ~ Choose a Wing Axle Kit ~ ~

| | | | | |
|----|----------|---|----------|----------|
| 1) | C350-820 | Walking (Axles Included) | 2,337.00 | 1,589.16 |
| 2) | C350-830 | Non Walking (2 Tire Kit, Axles Included) | 969.00 | 658.92 |
| 3) | C350-825 | Non Walking (4 Tire Kit, Axles Included) | 1,372.00 | 932.96 |

~ ~ Selection 7 ~ Choose a Tire Option ~ ~

Please state the quantity of tires that you would like to order as the numbers listed below are just single tires and not a tire kit.

| | | | Retail Price/Tire | Contract Price/Tire |
|---|------------|---|-------------------|---------------------|
| 1) | 210-186WG | 27 X 10.5-15 Skid Steer Tire, LEFT | 492.00 | 334.56 |
| 2) | 210-187WG | 27 X 10.5-15 Skid Steer Tire, RIGHT | 492.00 | 334.56 |
| 3) | 210-186FWG | Foam Filled, 27 X 10.5-15 Skid Steer Tire, LEFT | 1,169.00 | 794.92 |
| 4) | 210-187FWG | Foam Filled, 27 X 10.5-15 Skid Steer Tire, RIGHT | 1,169.00 | 794.92 |
| NOTE: If choosing skid steer tires, be sure to choose correct amount of left & right tires | | | | |
| 5) | 210-182WG | Aircraft Tire (29 x 9-15/16 ply) | 524.00 | 356.32 |
| 6) | 210-182FWG | Foam Filled Aircraft Tire (29 x 9-15/16 ply) | 917.00 | 623.56 |
| 7) | 210-192WG | Solid Laminated Tire, 6 x 9 x 26 | 509.00 | 346.12 |

~ ~ Selection 8 ~ Choose a Destination Package ~ ~

Please select the destination of the cutter for proper Decals, Manuals, and Shielding

| | | | | |
|----|---------|--|-------|-------|
| 1) | C350-NA | North American/ Australia Destination Kits | 67.00 | 45.56 |
|----|---------|--|-------|-------|

*** Above prices subject to a 4% steel tariff surcharge**

MASTER PRICE SHEET



Schulte Industries Ltd.

100 John Schulte Dr., Englefeld, SK. Canada, S0K 1N0

Tel: 306-287-3715 Fax: 306-287-3355 Toll Free: 1-800-404-6044

Web: www.Schulte.ca



Sourcewell - Road Right Of Way Maintenance Equipment

MACHINE PRICES AND SPECIFICATIONS

XH1500 Series 5 Rotary Cutter

~ ~ Selection 9 ~ Extra Options ~ ~

| | | | | |
|------------------------|----------|----------------------------|-----------------|---------------|
| 1) | C350-540 | Rear Half Belting Kit | 782.00 | 531.76 |
| 2) | C308-890 | Tire Bumper Kit | 895.00 | 608.60 |
| 3) | C350-880 | Right Hand Gauge Wheel Kit | 904.00 | 614.72 |
| 4) | C350-885 | Left Hand Gauge Wheel Kit | 904.00 | 614.72 |
| 5) | C306-305 | Flex Arm Mount | 214.00 | 145.52 |
| 6) | C000-620 | Toolbox Mount & Toolbox | 1,285.00 | 873.80 |
| Assembly Charge | | | Net | 400.00 |

OPTIONAL PDI INCLUDES: greasing of all pivot points, gearbox oil checked, charge hydraulic cylinders and install pioneer ends. Tires will be installed where necessary. It is the dealers responsibility to remove shipping brackets & banding as well as to adjust mower height as specified in the operators manual. Please go to the Schulte website/dealer access for further information.

PREDELIVERY SERVICE IS REQUIRED BY DEALER OR END USER



*** Above prices subject to a 4% steel tariff surcharge**

MASTER PRICE SHEET



Schulte Industries Ltd.

100 John Schulte Dr., Englefeld, SK. Canada, S0K 1N0

Tel: 306-287-3715 Fax: 306-287-3355 Toll Free: 1-800-404-6044

Web: www.Schulte.ca

Sourcewell - Road Right Of Way Maintenance Equipment

MACHINE PRICES AND SPECIFICATIONS

XH1500 Series 5 Rotary Cutter SFT Pro Drivelines



CUTTER FEATURES

- 7GA deck
- Replaceable skid shoes
- Double safety chains front & rear
- Hydraulic phasing lift system
- Hydraulic wing lift system
- 517 Hubs and axles
- Single domed, sweep clean deck
- Rubber suspension - standard
- Four gearbox drive layout
240hp down, 275hp splitter
- Full floating front hitch
- Deck protection rings
- S000-010 safety chain kit 1/4" grade 70
with 10,000 lbs capacity
- 1/4" Round skid pans (Stump Jumpers)
- Pentagon blade bolt design
- Operator's manual in holder

~ ~ Selection 1 ~ Choose a Basic Unit ~ ~

| | | Retail Price | Contract Price |
|--------------------------------|---|---------------------|-----------------------|
| 1) | C350-100 Basic Unit XH Series 5 | 23,663.00 | 16,090.84 |
| 2) | C350-200 15' Option (Required) | 18,234.00 | 12,399.12 |
| 3) | S000-160 Safety Light Kit (Required) | 876.00 | 595.68 |
| 4) | C301-830 ISO Couplers (Required) | 79.00 | 53.72 |
| Choose a Drive Package: | | | |
| a) | C350-705PRO SFT Pro Package - CW Rotation Center 540 RPM (Std. Rotation) | 11,415.00 | 7,762.20 |
| b) | C350-715PRO SFT Pro Package - CW Rotation Center 1000 RPM (Std. Rotation) | 11,415.00 | 7,762.20 |
| c) | C350-700PRO SFT Pro Package - CCW Rotation on Center 540 RPM (Non Std Rotation) | 11,415.00 | 7,762.20 |
| d) | C350-710PRO SFT Pro Package - CCW Rotation on Center 1000 RPM (Non Std. Rotation) | 11,415.00 | 7,762.20 |

~ ~ Selection 2 ~ Choose a Hitch Type and Accessories ~ ~

| | | | |
|--------------------------------|---|----------|----------|
| 1) | C350-180 Trailing Hitch CV Style | 1,096.00 | 745.28 |
| Choose a Clevis: | | | |
| a) | C000-506WG Open Clevis (Minimum Requirement with a Flex Arm) | 475.00 | 323.00 |
| b) | C000-500WG Precision Hitch (Can be used with a Flex Arm) | 860.00 | 584.80 |
| c) | C000-513WG Solid tongue (Can be used with a Flex Arm) | 558.00 | 379.44 |
| d) | C000-515WG Clevis 2 3/16 " opening (Can be used with a Flex Arm) | 600.00 | 408.00 |
| e) | C000-510WG Pro Level Hitch (Can NOT be used with a Flex Arm) | 776.00 | 527.68 |
| Choose a Tractor Shaft: | | | |
| a) | 340-F501WG SFT Pro CV Shaft, 540 rpm | 4,155.00 | 2,825.40 |
| b) | 340-F401WG SFT Pro CV Shaft, 1000 rpm, 1-3/8" Shaft | 3,945.00 | 2,682.60 |
| 2) | C350-196 Equal Angle Hitch Kit w/ 540 RPM Shaft | 3,382.00 | 2,299.76 |

~ ~ Selection 3 ~ Choose Hydraulic Option ~ ~

| | | | |
|----|---|--------|--------|
| 1) | C350-805 Independent Double Acting Hose Kit OR | 415.00 | 282.20 |
| 2) | C350-810 Double Acting Hose Kit | 374.00 | 254.32 |

*** Above prices subject to a 4% steel tariff surcharge**

MASTER PRICE SHEET



Schulte Industries Ltd.

100 John Schulte Dr., Englefeld, SK. Canada, S0K 1N0

Tel: 306-287-3715 Fax: 306-287-3355 Toll Free: 1-800-404-6044

Web: www.Schulte.ca



Sourcewell - Road Right Of Way Maintenance Equipment

MACHINE PRICES AND SPECIFICATIONS

XH1500 Series 5 Rotary Cutter SFT Pro Drivelines

~ ~ Selection 4 ~ Choose a Blade Configuration ~ ~

| | | | | |
|----|----------|---|--------|--------|
| 1) | C350-450 | 2 Blade Pan Kit - cw Schulte Super Suction Updraft 4" Blades | 465.00 | 316.20 |
| 2) | C350-451 | 2 Blade Pan Kit - ccw Schulte Super Suction Updraft 4" Blades | 465.00 | 316.20 |
| 3) | C350-455 | 2 Blade Pan Kit - cw Schulte Super Suction Updraft 5" Blades | 555.00 | 377.40 |
| 4) | C350-456 | 2 Blade Pan Kit - ccw Schulte Super Suction Updraft 5" Blades | 555.00 | 377.40 |

~ ~ Selection 5 ~ Choose a Center Axle Kit ~ ~

| | | | | |
|----|----------|---|----------|----------|
| 1) | C350-820 | Walking (Axles Included) | 2,337.00 | 1,589.16 |
| 2) | C350-825 | Non Walking (4 Tire Kit, Axles Included) | 1,372.00 | 932.96 |
| 3) | C350-350 | Large Tire Option - Center Section (2 Tires) | 3,651.00 | 2,482.68 |

C350-350 Includes mounts & tires - Only select tires for the wing axle option

~ ~ Selection 6 ~ Choose a Wing Axle Kit ~ ~

| | | | | |
|----|----------|---|----------|----------|
| 1) | C350-820 | Walking (Axles Included) | 2,337.00 | 1,589.16 |
| 2) | C350-830 | Non Walking (2 Tire Kit, Axles Included) | 969.00 | 658.92 |
| 3) | C350-825 | Non Walking (4 Tire Kit, Axles Included) | 1,372.00 | 932.96 |

~ ~ Selection 7 ~ Choose a Tire Option ~ ~

Please state the quantity of tires that you would like to order as the numbers listed below are just single tires and not a tire kit.

| | | | Retail Price/Tire | Contract Price/Tire |
|---|------------|---|-------------------|---------------------|
| 1) | 210-186WG | 27 X 10.5-15 Skid Steer Tire, LEFT | 492.00 | 334.56 |
| 2) | 210-187WG | 27 X 10.5-15 Skid Steer Tire, RIGHT | 492.00 | 334.56 |
| 3) | 210-186FWG | Foam Filled, 27 X 10.5-15 Skid Steer Tire, LEFT | 1,169.00 | 794.92 |
| 4) | 210-187FWG | Foam Filled, 27 X 10.5-15 Skid Steer Tire, RIGHT | 1,169.00 | 794.92 |
| NOTE: If choosing skid steer tires, be sure to choose correct amount of left & right tires | | | | |
| 5) | 210-182WG | Aircraft Tire (29 x 9-15/16 ply) | 524.00 | 356.32 |
| 6) | 210-182FWG | Foam Filled Aircraft Tire (29 x 9-15/16 ply) | 917.00 | 623.56 |
| 7) | 210-192WG | Solid Laminated Tire, 6 x 9 x 26 | 509.00 | 346.12 |

~ ~ Selection 8 ~ Choose a Destination Package ~ ~

Please select the destination of the cutter for proper Decals, Manuals, and Shielding

| | | | | |
|----|---------|--|-------|-------|
| 1) | C350-NA | North American/ Australia Destination Kits | 67.00 | 45.56 |
|----|---------|--|-------|-------|

*** Above prices subject to a 4% steel tariff surcharge**

MASTER PRICE SHEET



Schulte Industries Ltd.

100 John Schulte Dr., Englefeld, SK. Canada, S0K 1N0

Tel: 306-287-3715 Fax: 306-287-3355 Toll Free: 1-800-404-6044

Web: www.Schulte.ca



Sourcewell - Road Right Of Way Maintenance Equipment

MACHINE PRICES AND SPECIFICATIONS

XH1500 Series 5 Rotary Cutter

SFT Pro Drivelines

~ ~ Selection 9 ~ Extra Options ~ ~

| | | | | |
|------------------------|----------|----------------------------|-----------------|---------------|
| 1) | C350-540 | Rear Half Belting Kit | 782.00 | 531.76 |
| 2) | C308-890 | Tire Bumper Kit | 895.00 | 608.60 |
| 3) | C350-880 | Right Hand Gauge Wheel Kit | 904.00 | 614.72 |
| 4) | C350-885 | Left Hand Gauge Wheel Kit | 904.00 | 614.72 |
| 5) | C306-305 | Flex Arm Mount | 214.00 | 145.52 |
| 6) | C000-620 | Toolbox Mount & Toolbox | 1,285.00 | 873.80 |
| Assembly Charge | | | Net | 400.00 |

OPTIONAL PDI INCLUDES: greasing of all pivot points, gearbox oil checked, charge hydraulic cylinders and install pioneer ends. Tires will be installed where necessary. It is the dealers responsibility to remove shipping brackets & banding as well as to adjust mower height as specified in the operators manual. Please go to the Schulte website/dealer access for further information.

PREDELIVERY SERVICE IS REQUIRED BY DEALER OR END USER



*** Above prices subject to a 4% steel tariff surcharge**

MASTER PRICE SHEET



Schulte Industries Ltd.

100 John Schulte Dr., Englefeld, SK. Canada, S0K 1N0

Tel: 306-287-3715 Fax: 306-287-3355 Toll Free: 1-800-404-6044

Web: www.Schulte.ca



Sourcewell - Road Right Of Way Maintenance Equipment

MACHINE PRICES AND SPECIFICATIONS

Cutter Command System

CUTTER COMMAND SYSTEM FEATURES

- Speed sensors measure RPM to detect slipping and alert the operator
- Temperature sensors measure the gearboxes oil temperature
- Minimizes the risk of premature gearbox failures
- System logs the total working hours of the cutter
- System provides service reminders at the appropriate time intervals
- Helps prevent clutch overheating
- Helps reduce downtime and repair costs
- Streamlines billing and improves operations

~ ~ XH1500 Series 5 Cutter Command System ~ ~

| | | <i>Retail Price</i> | <i>Contract Price</i> |
|----|---|---------------------|-----------------------|
| 1) | C350-910 XH1500 1000RPM Monitor System - Customer Installed | 8,450.00 | 5,746.00 |
| 2) | C350-915 XH1500 1000RPM Monitor System - Factory Installed | 9,495.00 | 6,456.60 |
| 3) | C350-930 XH1500 540RPM Monitor System - Customer Installed | 8,450.00 | 5,746.00 |
| 4) | C350-935 XH1500 540RPM Monitor System - Factory Installed | 9,495.00 | 6,456.60 |

~ ~ XH1000 Series 5 Cutter Command System ~ ~

| | | | |
|----|---|----------|----------|
| 1) | C350-920 XH1000 1000RPM Monitor System - Customer Installed | 7,250.00 | 4,930.00 |
| 2) | C350-925 XH1000 1000RPM Monitor System - Factory Installed | 7,895.00 | 5,368.60 |
| 3) | C350-940 XH1000 540RPM Monitor System - Customer Installed | 7,250.00 | 4,930.00 |
| 4) | C350-945 XH1000 540RPM Monitor System - Factory Installed | 7,895.00 | 5,368.60 |



* Above prices subject to a 4% steel tariff surcharge

MASTER PRICE SHEET



Schulte Industries Ltd.

100 John Schulte Dr., Englefeld, SK. Canada, S0K 1N0

Tel: 306-287-3715 Fax: 306-287-3355 Toll Free: 1-800-404-6044

Web: www.Schulte.ca



Sourcewell - Road Right Of Way Maintenance Equipment

MACHINE PRICES AND SPECIFICATIONS

XH1000 Series 5 Rotary Cutter

CUTTER FEATURES

- 7GA deck
- Replaceable skid shoes
- Double safety chains front & rear
- Hydraulic phasing lift system
- Hydraulic wing lift system
- 517 Hubs and axles
- Single domed, sweep clean deck
- Rubber suspension - standard
- Four gearbox drive layout
- 240hp down, 275hp splitter
- Full floating front hitch
- Deck protection rings
- S000-010 safety chain kit 1/4" grade 70 with 10,000 lbs capacity
- 1/4" Round skid pans (Stump Jumpers)
- Pentagon blade bolt design
- Operator's manual in holder

~ ~ Selection 1 ~ Choose a Basic Unit and Drive Package ~ ~

| | | Retail Price | Contract Price |
|----|--|--------------|----------------|
| 1) | C350-100 Basic Unit XH Series 5 | 23,663.00 | 16,090.84 |
| 2) | C350-250 10' Option (Required) | 16,684.00 | 11,345.12 |
| 3) | S000-165 Safety Light Kit (Required) | 693.00 | 471.24 |
| 4) | C302-830 ISO Couplers (Required) | 61.00 | 41.48 |
| | Choose a Drive Package: | | |
| a) | C350-745 CW Rotation on Center, 540 RPM, (Std. Rotation) | 5,465.00 | 3,716.20 |
| b) | C350-755 CW Rotation on Center, 1000 RPM (Std. Rotation) | 5,465.00 | 3,716.20 |

~ ~ Selection 2 ~ Choose a Hitch Type and Accessories ~ ~

| | | | |
|----|---|----------|----------|
| 1) | C350-180 Trailing Hitch CV Style | 1,096.00 | 745.28 |
| | Choose a Clevis: | | |
| a) | C000-506WG Open Clevis (Minimum Requirement with a Flex Arm) | 475.00 | 323.00 |
| b) | C000-500WG Precision Hitch (Can be used with a Flex Arm) | 860.00 | 584.80 |
| c) | C000-513WG Solid tongue (Can be used with a Flex Arm) | 558.00 | 379.44 |
| d) | C000-515WG Clevis 2 3/16 " opening (Can be used with a Flex Arm) | 600.00 | 408.00 |
| e) | C000-510WG Pro Level Hitch (Can <u>NOT</u> be used with a Flex Arm) | 776.00 | 527.68 |
| | Choose a Tractor Shaft: | | |
| a) | 340-870WG CV Shaft, 540 rpm | 1,880.00 | 1,278.40 |
| b) | 340-648WG CV Shaft, 1000 rpm | 1,557.00 | 1,058.76 |
| c) | 340-658WG CV Shaft 1000 RPM 1 3/4" shaft | 2,050.00 | 1,394.00 |
| 2) | C350-196 Equal Angle Hitch Kit w/ 540 RPM Shaft | 3,382.00 | 2,299.76 |

~ ~ Selection 3 ~ Choose Hydraulic Option ~ ~

| | | | |
|----|---|--------|--------|
| 1) | C350-815 Independent Double Acting Hose Kit Required | 214.00 | 145.52 |
|----|---|--------|--------|

* Above prices subject to a 4% steel tariff surcharge

MASTER PRICE SHEET



Schulte Industries Ltd.

100 John Schulte Dr., Englefeld, SK. Canada, S0K 1N0

Tel: 306-287-3715 Fax: 306-287-3355 Toll Free: 1-800-404-6044

Web: www.Schulte.ca



Sourcewell - Road Right Of Way Maintenance Equipment

MACHINE PRICES AND SPECIFICATIONS

XH1000 Series 5 Rotary Cutter

~ ~ Selection 4 ~ Choose a Blade Configuration ~ ~

| | | | | |
|----|----------|--|--------|--------|
| 1) | C350-470 | 2 Blade Pan kit - CW Schulte Super Suction Updraft 4" Blades | 299.00 | 203.32 |
| 2) | C350-475 | 2 Blade Pan kit - CW Schulte Super Suction Updraft 5" Blades | 378.00 | 257.04 |

~ ~ Selection 5 ~ Choose a Center Axle Kit ~ ~

| | | | | |
|----|----------|---|----------|----------|
| 1) | C350-820 | Walking Axle <i>(Axles Included)</i> | 2,337.00 | 1,589.16 |
| 2) | C350-825 | Non Walking <i>(4 Tire Kit, Axles Included)</i> | 1,372.00 | 932.96 |
| 3) | C350-350 | Large Tire Option - Center Section <i>(2 Tires)</i> | 3,651.00 | 2,482.68 |

C350-350 Includes mounts & tires - Only select tires for the wing axle option

~ ~ Selection 6 ~ Choose a Wing Axle Kit ~ ~

| | | | | |
|----|----------|---|----------|--------|
| 1) | C350-835 | Walking Axle <i>(Axle Included)</i> | 1,162.00 | 790.16 |
| 2) | C350-840 | Non Walking <i>(1 Tire Kit, Axle Included)</i> | 486.00 | 330.48 |
| 3) | C350-845 | Non Walking <i>(2 Tire Kit, Axles Included)</i> | 687.00 | 467.16 |

~ ~ Selection 7 ~ Choose a Tire Option ~ ~

Please state the quantity of tires that you would like to order as the numbers listed below are just single tires and not a tire kit.

| | | | Retail Price/Tire | Contract Price/Tire |
|---|------------|---|-------------------|---------------------|
| 1) | 210-186WG | 27 X 10.5-15 Skid Steer Tire, LEFT | 492.00 | 334.56 |
| 2) | 210-187WG | 27 X 10.5-15 Skid Steer Tire, RIGHT | 492.00 | 334.56 |
| 3) | 210-186FWG | Foam Filled, 27 X 10.5-15 Skid Steer Tire, LEFT | 1,169.00 | 794.92 |
| 4) | 210-187FWG | Foam Filled, 27 X 10.5-15 Skid Steer Tire, RIGHT | 1,169.00 | 794.92 |
| NOTE: If choosing skid steer tires, be sure to choose correct amount of left & right tires | | | | |
| 5) | 210-182WG | Aircraft Tire (29 x 9-15/16 Ply) | 524.00 | 356.32 |
| 6) | 210-182FWG | Foam Filled Aircraft Tire (29 x 9-15/16 Ply) | 917.00 | 623.56 |
| 7) | 210-192WG | Solid Laminated Tire, 6 x 9 x 26 | 509.00 | 346.12 |

~ ~ Selection 8 ~ Choose a Destination Package ~ ~

Please select the destination of the cutter for proper Decals, Manuals, and Shielding

| | | | | |
|----|-----------|--|-------|-------|
| 1) | C350-NA10 | North American/ Australia Destination Kits | 67.00 | 45.56 |
|----|-----------|--|-------|-------|

*** Above prices subject to a 4% steel tariff surcharge**

MASTER PRICE SHEET



Schulte Industries Ltd.

100 John Schulte Dr., Englefeld, SK. Canada, S0K 1N0

Tel: 306-287-3715 Fax: 306-287-3355 Toll Free: 1-800-404-6044

Web: www.Schulte.ca



Sourcewell - Road Right Of Way Maintenance Equipment

MACHINE PRICES AND SPECIFICATIONS

XH1000 Series 5 Rotary Cutter

~ ~ Selection 9 ~ Extra Options ~ ~

| | | | | |
|------------------------|----------|---------------------------------|-----------------|---------------|
| 1) | C350-550 | XH1000 S5 Rear Half Belting Kit | 577.00 | 392.36 |
| 2) | C350-880 | Right Hand Gauge Wheel Kit | 904.00 | 614.72 |
| 3) | C306-305 | Flex Arm Mount | 214.00 | 145.52 |
| 4) | C000-620 | Toolbox Mount & Toolbox | 1,285.00 | 873.80 |
| Assembly Charge | | | Net | 300.00 |

OPTIONAL PDI INCLUDES: greasing of all pivot points, gearbox oil checked, charge hydraulic cylinders and install pioneer ends. Tires will be installed where necessary. It is the dealers responsibility to remove shipping brackets & banding as well as to adjust mower height as specified in the operators manual. Please go to the Schulte website/dealer access for further information.

PREDELIVERY SERVICE IS REQUIRED BY DEALER OR END USER



*** Above prices subject to a 4% steel tariff surcharge**

MASTER PRICE SHEET



Schulte Industries Ltd.

100 John Schulte Dr., Englefeld, SK. Canada, S0K 1N0

Tel: 306-287-3715 Fax: 306-287-3355 Toll Free: 1-800-404-6044

Web: www.Schulte.ca



Sourcewell - Road Right Of Way Maintenance Equipment

MACHINE PRICES AND SPECIFICATIONS

FX-1800 Rotary Cutter (Pan Unit)

CUTTER FEATURES

- 540/1000 RPM Drive
- 7 ga. Spun Formed Stump Jumpers
- Replaceable Skid Shoes
- 7 ga Single Domed Deck
- Deck Protection Rings
- Over Center Folding Wings
- Transport Width (max with duals on wings) 102"(2.59m)
- 80 Degree CV Drive
- Height Control Cylinder & Hoses
- Wing Lift Cylinders & Hoses
- S000-010 Safety Chain (1/4" gr.70 - 10000lbs cap.)
- Operator's and Parts Manual Holder
- Cutting Width 180" (4.57m)

~ ~ Selection 1 ~ Choose a Basic Unit, Drive Package ~ ~

| | | Retail Price | Contract Price |
|-------------------------|---|--------------|----------------|
| C185-100 | Schulte FX-1800, Basic Unit | 21,620.00 | 14,701.60 |
| S000-085 | Safety Light Kit (Required) | 673.00 | 457.64 |
| Choose a Drive Package: | | | |
| a) | C306-705 Drive Package, CW Center, 540 RPM | 7,425.00 | 5,049.00 |
| b) | C306-715 Drive Package, CW Center, 1000 RPM | 7,425.00 | 5,049.00 |

~ ~ Selection 2 ~ Choose a Hitch Option ~ ~

| | | | |
|--------------------|--|----------|----------|
| C185-180 | Trailing Hitch, CV Style | 997.00 | 677.96 |
| Choose a CV Shaft: | | | |
| a) | 340-870WG CV Shaft, 540 RPM | 1,880.00 | 1,278.40 |
| b) | 340-648WG CV Shaft, 1000 RPM | 1,557.00 | 1,058.76 |
| c) | 340-658WG CV Shaft 1000 RPM 1 3/4" shaft | 2,050.00 | 1,394.00 |
| C185-196 | Equal Angle Hitch Kit w/ 540 RPM Shaft | 3,180.00 | 2,162.40 |

~ ~ Selection 3 ~ Choose a Clevis ~ ~

| | | | |
|------------|------------------------------------|--------|--------|
| C000-506WG | Open Clevis (Minimum Requirements) | 475.00 | 323.00 |
| C000-500WG | Precision hitch | 860.00 | 584.80 |
| C000-513WG | Solid Tongue | 558.00 | 379.44 |
| C000-510WG | Pro Level Hitch | 776.00 | 527.68 |

~ ~ Selection 4 ~ Choose One Center Axle Mount Style ~ ~

| | | | |
|----------|--|----------|----------|
| C185-820 | Walking (Axles Included) | 2,971.00 | 2,020.28 |
| C185-830 | Non Walking (2 Tire Kit, Axles Included) | 1,059.00 | 720.12 |
| C185-825 | Non Walking (4 Tire Kit, Axles Included) | 1,649.00 | 1,121.32 |

* Above prices subject to a 4% steel tariff surcharge

MASTER PRICE SHEET



Schulte Industries Ltd.

100 John Schulte Dr., Englefeld, SK. Canada, S0K 1N0

Tel: 306-287-3715 Fax: 306-287-3355 Toll Free: 1-800-404-6044

Web: www.Schulte.ca



Sourcewell - Road Right Of Way Maintenance Equipment

MACHINE PRICES AND SPECIFICATIONS

FX-1800 Rotary Cutter (Pan Unit)

~ ~ Selection 5 ~ Choose One Wing Axle Mount Style ~ ~

| | | | |
|----------|---|----------|----------|
| C185-820 | Walking <i>(Axles Included)</i> | 2,971.00 | 2,020.28 |
| C185-830 | Non Walking <i>(2 Tire Kit, Axles Included)</i> | 1,059.00 | 720.12 |
| C185-825 | Non Walking <i>(4 Tire Kit, Axles Included)</i> | 1,649.00 | 1,121.32 |

~ ~ Selection 6 ~ Choose a Safety Guard ~ ~

| | | | |
|----------|------------------------------------|----------|----------|
| C180-520 | Chain Guards Single Front and Rear | 1,318.00 | 896.24 |
| C180-500 | Chain Guards Double Front and Rear | 1,671.00 | 1,136.28 |

~ ~ Selection 7 ~ Choose a Pan Kit ~ ~

| | | | |
|----------|--------------------|----------|----------|
| C316-450 | Pan Kit (required) | 2,239.00 | 1,522.52 |
|----------|--------------------|----------|----------|

~ ~ Selection 8 ~ Choose a Blade Configuration ~ ~

| | | | | |
|----------|--|----|--------|--------|
| C316-451 | CW Schulte Super Suction Updraft 4" Blades | Or | 657.00 | 446.76 |
| C316-459 | CW Schulte Super Suction Updraft 5" Blades | | 845.00 | 574.60 |

~ ~ Selection 9 ~ Choose a Tire Option ~ ~

Please state the quantity of tires that you would like to order as the numbers listed below are single tires and not tire kits.

| | | Retail Price/Tire | Contract Price/Tire |
|------------|---|-------------------|---------------------|
| 210-003WG | Solid Laminated Tires, 6 x 9 x 20 | 316.00 | 214.88 |
| 210-175WG | Forklift Tire 6.5 x 10 - 12 ply on 2 pce 5 bolt rim | 445.00 | 302.60 |
| 210-175FWG | Foam Filled Forklift Tire 6.5 x 10 - 12 ply on 2 pce 5 bolt rim | 776.00 | 527.68 |
| 210-540WG | Tire 24x8-14 20 Ply Rated Severe Duty | 519.00 | 352.92 |
| 210-540FWG | Tire 24x8-14 20 Ply Rated Severe Duty Foam Filled | 825.00 | 561.00 |
| 210-192WG | Solid Laminated Tire, 6 x 9 x 26 | 509.00 | 346.12 |

~ ~ Selection 10 ~ Choose a Destination Code ~ ~

| | | | |
|---------|---------------------------------------|-------|-------|
| C185-NA | North American & Australian Decal Kit | 67.00 | 45.56 |
|---------|---------------------------------------|-------|-------|

* Above prices subject to a 4% steel tariff surcharge

MASTER PRICE SHEET



Schulte Industries Ltd.

100 John Schulte Dr., Englefeld, SK. Canada, S0K 1N0

Tel: 306-287-3715 Fax: 306-287-3355 Toll Free: 1-800-404-6044

Web: www.Schulte.ca



Sourcewell - Road Right Of Way Maintenance Equipment

MACHINE PRICES AND SPECIFICATIONS

FX-1800 Rotary Cutter (Pan Unit)

~ ~ Selection 11 ~ Choose Extra Options ~ ~

| | | | |
|----------|--|----------|--------|
| C185-304 | Strut Mount for Flex Arm,(Factory Installed) | 876.00 | 595.68 |
| C185-305 | Strut Mount for Flex Arm, (parts only) | 368.00 | 250.24 |
| C185-325 | Tension Link Leveling Rod , Factory Installed | 310.00 | 210.80 |
| C185-330 | Tension Link Leveling Rod , Weld on Parts only | 388.00 | 263.84 |
| C185-310 | Hose Kit, independent wing-lift | 225.00 | 153.00 |
| C000-620 | Toolbox Mount & Toolbox | 1,285.00 | 873.80 |
| | Assembly Charge on Pan Units | Net | 400.00 |



* Above prices subject to a 4% steel tariff surcharge

MASTER PRICE SHEET



Schulte Industries Ltd.

100 John Schulte Dr., Englefeld, SK. Canada, S0K 1N0

Tel: 306-287-3715 Fax: 306-287-3355 Toll Free: 1-800-404-6044

Web: www.Schulte.ca



Sourcewell - Road Right Of Way Maintenance Equipment

MACHINE PRICES AND SPECIFICATIONS

FX-1800C Rotary Cutter (DOT Configuration Options)

CUTTER FEATURES

- 540/1000 RPM Drive
- 7 ga. Spun Formed Stump Jumpers
- Replaceable Skid Shoes
- 7 ga Single Domed Deck cap.)
- Deck Protection Rings
- Over Center Folding Wings
- Transport Width (max with duals on wings) 102"(2.59m)
- 80 Degree CV Drive
- Height Control Cylinder & Hoses
- Wing Lift Cylinders & Hoses
- S000-010 Safety Chain (1/4" gr.70 - 10000lbs)
- Operator's and Parts Manual Holder
- Cutting Width 180" (4.57m)

~ ~ Selection 1 ~ Choose a Basic Unit, Drive Package ~ ~

| | | Retail Price | Contract Price |
|-------------------------|--|--------------|----------------|
| C186-100 | Schulte FX-1800C, Basic Unit <i>c/w replaceable side bands & hydraulic phasing system</i> | 24,265.00 | 16,500.20 |
| S000-085 | Safety Light Kit (Required) | 673.00 | 457.64 |
| Choose a Drive Package: | | | |
| a) | C306-705 Drive Package, CW Center, 540 RPM | 7,425.00 | 5,049.00 |
| b) | C306-715 Drive Package, CW Center, 1000 RPM | 7,425.00 | 5,049.00 |

~ ~ Selection 2 ~ Choose a Hitch Option ~ ~

| | | | |
|--------------------|--|----------|----------|
| C185-180 | Trailing Hitch, CV Style | 997.00 | 677.96 |
| Choose a CV Shaft: | | | |
| a) | 340-870WG CV Shaft, 540 RPM | 1,880.00 | 1,278.40 |
| b) | 340-648WG CV Shaft, 1000 RPM | 1,557.00 | 1,058.76 |
| c) | 340-658WG CV Shaft 1000 RPM 1 3/4" shaft | 2,050.00 | 1,394.00 |
| C185-196 | Equal Angle Hitch Kit w/ 540 RPM Shaft | 3,180.00 | 2,162.40 |

~ ~ Selection 3 ~ Choose a Clevis ~ ~

| | | | |
|------------|------------------------------------|--------|--------|
| C000-506WG | Open Clevis (Minimum Requirements) | 475.00 | 323.00 |
| C000-500WG | Precision hitch | 860.00 | 584.80 |
| C000-513WG | Solid Tongue | 558.00 | 379.44 |
| C000-510WG | Pro Level Hitch | 776.00 | 527.68 |

~ ~ Selection 4 ~ Choose One Center Axle Mount Style ~ ~

| | | | |
|----------|---|----------|----------|
| C185-820 | Walking (Axles Included) | 2,971.00 | 2,020.28 |
| C185-830 | Non Walking (2 Tire Kit, Axles Included) | 1,059.00 | 720.12 |
| C185-825 | Non Walking (4 Tire Kit, Axles Included) | 1,649.00 | 1,121.32 |
| C186-880 | Wheel Mounts For Large Tires (Includes hubs/spindles & Tires) | 4,150.00 | 2,822.00 |

If choosing the C186-880, you MUST choose the C185-830 wing axle mount and two tires

*** Above prices subject to a 4% steel tariff surcharge**

MASTER PRICE SHEET



Schulte Industries Ltd.

100 John Schulte Dr., Englefeld, SK. Canada, S0K 1N0

Tel: 306-287-3715 Fax: 306-287-3355 Toll Free: 1-800-404-6044

Web: www.Schulte.ca



Sourcewell - Road Right Of Way Maintenance Equipment

MACHINE PRICES AND SPECIFICATIONS

FX-1800C Rotary Cutter (DOT Configuration Options)

~ ~ Selection 5 ~ Choose One Wing Axle Mount Style ~ ~

| | | | |
|----------|---|----------|----------|
| C185-820 | Walking <i>(Axles Included)</i> | 2,971.00 | 2,020.28 |
| C185-830 | Non Walking <i>(2 Tire Kit, Axles Included)</i> | 1,059.00 | 720.12 |
| C185-825 | Non Walking <i>(4 Tire Kit, Axles Included)</i> | 1,649.00 | 1,121.32 |

~ ~ Selection 6 ~ Choose a Safety Guard ~ ~

| | | | |
|----------|------------------------------------|----------|----------|
| C180-520 | Chain Guards Single Front and Rear | 1,318.00 | 896.24 |
| C180-500 | Chain Guards Double Front and Rear | 1,671.00 | 1,136.28 |

~ ~ Selection 7 ~ Choose a Pan Kit ~ ~

| | | | |
|----------|--------------------|----------|----------|
| C316-450 | Pan Kit (required) | 2,239.00 | 1,522.52 |
|----------|--------------------|----------|----------|

~ ~ Selection 8 ~ Choose a Blade Configuration ~ ~

| | | | | |
|----------|--|----|--------|--------|
| C316-451 | CW Schulte Super Suction Updraft 4" Blades | Or | 657.00 | 446.76 |
| C316-459 | CW Schulte Super Suction Updraft 5" Blades | | 845.00 | 574.60 |

~ ~ Selection 9 ~ Choose a Tire Option ~ ~

Please state the quantity of tires that you would like to order as the numbers listed below are single tires and not tire kits.

| | | Retail Price/Tire | Contract Price/Tire |
|------------|---|-------------------|---------------------|
| 210-003WG | Solid Laminated Tires, 6 x 9 x 20 | 316.00 | 214.88 |
| 210-175WG | Forklift Tire 6.5 x 10 - 12 ply on 2 pce 5 bolt rim | 445.00 | 302.60 |
| 210-175FWG | Foam Filled Forklift Tire 6.5 x 10 - 12 ply on 2 pce 5 bolt rim | 776.00 | 527.68 |
| 210-540WG | Tire 24x8-14 20 Ply Rated Severe Duty | 519.00 | 352.92 |
| 210-540FWG | Tire 24x8-14 20 Ply Rated Severe Duty Foam Filled | 825.00 | 561.00 |
| 210-192WG | Solid Laminated Tire, 6 x 9 x 26 | 509.00 | 346.12 |

~ ~ Selection 10 ~ Choose a Destination Code ~ ~

| | | | |
|---------|---------------------------------------|-------|-------|
| C185-NA | North American & Australian Decal Kit | 67.00 | 45.56 |
|---------|---------------------------------------|-------|-------|

* Above prices subject to a 4% steel tariff surcharge

MASTER PRICE SHEET



Schulte Industries Ltd.

100 John Schulte Dr., Englefeld, SK. Canada, S0K 1N0

Tel: 306-287-3715 Fax: 306-287-3355 Toll Free: 1-800-404-6044

Web: www.Schulte.ca



Sourcewell - Road Right Of Way Maintenance Equipment

MACHINE PRICES AND SPECIFICATIONS

FX-1800C Rotary Cutter (DOT Configuration Options)

~ ~ Selection 11 ~ Choose Extra Options ~ ~

| | | | |
|----------|--|-----------------|---------------|
| C185-304 | Strut Mount for Flex Arm,(Factory Installed) | 876.00 | 595.68 |
| C185-305 | Strut Mount for Flex Arm, (parts only) | 368.00 | 250.24 |
| C185-325 | Tension Link Leveling Rod , Factory Installed | 310.00 | 210.80 |
| C185-330 | Tension Link Leveling Rod , Weld on Parts only | 388.00 | 263.84 |
| C185-310 | Hose Kit, independent wing-lift | 225.00 | 153.00 |
| C000-620 | Toolbox Mount & Toolbox | 1,285.00 | 873.80 |
| | Assembly Charge on Pan Units | Net | 400.00 |



* Above prices subject to a 4% steel tariff surcharge

MASTER PRICE SHEET



Schulte Industries Ltd.

100 John Schulte Dr., Englefeld, SK. Canada, S0K 1N0

Tel: 306-287-3715 Fax: 306-287-3355 Toll Free: 1-800-404-6044

Web: www.Schulte.ca



Sourcewell - Road Right Of Way Maintenance Equipment

MACHINE PRICES AND SPECIFICATIONS

FX-1200 Rotary Cutter (Pan Unit)

CUTTER FEATURES

- 540/1000 RPM Drive
- 7 ga. Spun Formed Stump Jumpers
- Replaceable Skid Shoes
- 7 ga Single Domed Deck
- Deck Protection Rings
- Over Center Folding Wings
- Transport Width (max with duals on wings)97.5"(2.47m)
- 80 Degree CV Drive
- Height Control Cylinder & Hoses
- Wing Lift Cylinders & Hoses
- S000-010 Safety Chain (1/4" gr.70 - 10000lbs cap.)
- Operator's and Parts Manual Holder
- Cutting Width 126" (3.20m)

~ ~ Selection 1 ~ Choose a Basic Unit, Drive Package ~ ~

| | | Retail Price | Contract Price |
|-----------------------------------|---------------------------------|--------------|----------------|
| C195-100 | FX1200, Basic Unit | 21,735.00 | 14,779.80 |
| S000-085 | Safety Light Kit (Required) | 673.00 | 457.64 |
| <u>DRIVE PACKAGE (choose one)</u> | | | |
| C307-700 | CW Rotation on Center, 540 RPM | 5,415.00 | 3,682.20 |
| C307-710 | CW Rotation on Center, 1000 RPM | 5,415.00 | 3,682.20 |

~ ~ Selection 2 ~ Choose a Hitch Option ~ ~

| | | | |
|--------------------|--|----------|----------|
| C185-180 | Trailing Hitch, CV Style | 997.00 | 677.96 |
| Choose a CV Shaft: | | | |
| a) | 340-870WG CV Shaft, 540 RPM | 1,880.00 | 1,278.40 |
| b) | 340-648WG CV Shaft, 1000 RPM | 1,557.00 | 1,058.76 |
| C185-196 | Equal Angle Hitch Kit w/ 540 RPM Shaft | 3,180.00 | 2,162.40 |

~ ~ Selection 3 ~ Choose a Clevis ~ ~

| | | | |
|------------|-----------------------------------|--------|--------|
| C000-506WG | Open Clevis (Minimum Requirments) | 475.00 | 323.00 |
| C000-500WG | Precision hitch | 860.00 | 584.80 |
| C000-513WG | Solid Tongue | 558.00 | 379.44 |
| C000-510WG | Pro Level Hitch | 776.00 | 527.68 |

~ ~ Selection 4 ~ Choose One Center Axle Mount Style ~ ~

| | | | |
|----------|--|----------|----------|
| C185-820 | Walking (Axles Included) | 2,971.00 | 2,020.28 |
| C185-830 | Non Walking (2 Tire Kit, Axles Included) | 1,059.00 | 720.12 |
| C185-825 | Non Walking (4 Tire Kit, Axles Included) | 1,649.00 | 1,121.32 |

* Above prices subject to a 4% steel tariff surcharge

MASTER PRICE SHEET



Schulte Industries Ltd.

100 John Schulte Dr., Englefeld, SK. Canada, S0K 1N0
 Tel: 306-287-3715 Fax: 306-287-3355 Toll Free: 1-800-404-6044
 Web: www.Schulte.ca



Sourcewell - Road Right Of Way Maintenance Equipment

MACHINE PRICES AND SPECIFICATIONS

FX-1200 Rotary Cutter (Pan Unit)

~ ~ Selection 5 ~ Choose a Wing Axle Mount Style ~ ~

| | | | |
|----------|---|----------|--------|
| C185-835 | Walking Axle (Axle Included) | 1,402.00 | 953.36 |
| C185-840 | Non Walking (1 Tire Kit, Axle Included) | 524.00 | 356.32 |
| C185-845 | Non Walking (2 Tire Kit, Axles Included) | 730.00 | 496.40 |

~ ~ Selection 6 ~ Choose a Safety Guard ~ ~

| | | | |
|----------|----------------------------------|----------|--------|
| C190-520 | Chain Guards Single Front & Rear | 907.00 | 616.76 |
| C190-500 | Chain Guards Double Front & Rear | 1,156.00 | 786.08 |

~ ~ Selection 7 ~ Choose The Pan Kit ~ ~

| | | | |
|----------|--------------------|----------|----------|
| C317-450 | Pan Kit (required) | 1,476.00 | 1,003.68 |
|----------|--------------------|----------|----------|

~ ~ Selection 8 ~ Choose a Blade Configuration ~ ~

| | | | |
|----------|---------------------------|--------|--------|
| C317-451 | Updraft Blades, CW Center | 436.00 | 296.48 |
|----------|---------------------------|--------|--------|

~ ~ Selection 9 ~ Choose a Tire Option ~ ~

Please state the quantity of tires that you would like to order as the numbers listed below are single tires and not tire kits.

| | | Retail Price/Tire | Contract Price/Tire |
|------------|---|-------------------|---------------------|
| 210-003WG | Solid Laminated Tires, 6 x 9 x 20 | 316.00 | 214.88 |
| 210-175WG | Tire Assy, Forklift, 6.5 x 10 - 12 ply on 2 pce 5 bolt rim | 445.00 | 302.60 |
| 210-175FWG | Foam Filled Forklift Tire 6.5 x 10 - 12 ply on 2 pce 5 bolt rim | 776.00 | 527.68 |
| 210-540WG | Tire 24x8-14 20 Ply Rated Severe Duty | 519.00 | 352.92 |
| 210-540FWG | Tire 24x8-14 20 Ply Rated Severe Duty Foam Filled | 825.00 | 561.00 |
| 210-192WG | Solid Laminated Tire, 6 x 9 x 26 | 509.00 | 346.12 |

~ ~ Selection 10 ~ Choose a Destination Code ~ ~

| | | | |
|---------|---------------------------------------|-------|-------|
| C195-NA | North American & Australian Decal Kit | 57.00 | 38.76 |
|---------|---------------------------------------|-------|-------|

* Above prices subject to a 4% steel tariff surcharge

MASTER PRICE SHEET



Schulte Industries Ltd.

100 John Schulte Dr., Englefeld, SK. Canada, S0K 1N0

Tel: 306-287-3715 Fax: 306-287-3355 Toll Free: 1-800-404-6044

Web: www.Schulte.ca



Sourcewell - Road Right Of Way Maintenance Equipment

MACHINE PRICES AND SPECIFICATIONS

FX-1200 Rotary Cutter (Pan Unit)

~~ Selection 11 ~ Choose a Extra Options ~~

| | | | |
|------------------------|--|-----------------|---------------|
| C185-304 | Strut Mount for Flex Arm,(Factory Installed) | 876.00 | 595.68 |
| C185-305 | Strut Mount for Flex Arm, (parts only) | 368.00 | 250.24 |
| C185-325 | Tension Link Leveling Rod , Factory Installed | 310.00 | 210.80 |
| C185-330 | Tension Link Leveling Rod , Weld on Parts only | 388.00 | 263.84 |
| C000-620 | Toolbox Mount & Toolbox | 1,285.00 | 873.80 |
| Assembly Charge | | Net | 300.00 |



* Above prices subject to a 4% steel tariff surcharge

MASTER PRICE SHEET



Schulte Industries Ltd.

100 John Schulte Dr., Englefeld, SK. Canada, S0K 1N0

Tel: 306-287-3715 Fax: 306-287-3355 Toll Free: 1-800-404-6044

Web: www.Schulte.ca



Sourcewell - Road Right Of Way Maintenance Equipment

MACHINE PRICES AND SPECIFICATIONS

FX-1200C Rotary Cutter (DOT Configuration Options)

CUTTER FEATURES

- 540/1000 RPM Drive
- 7 ga. Spun Formed Stump Jumpers
- Replaceable Skid Shoes
- 7 ga Single Domed Deck
- Deck Protection Rings
- Over Center Folding Wings
- Transport Width (max with duals on wings) 97.5" (2.47m)
- 80 Degree CV Drive
- Height Control Cylinder & Hoses
- Wing Lift Cylinders & Hoses
- S000-010 Safety Chain (1/4" gr.70 - 10000lbs cap.)
- Operator's and Parts Manual Holder
- Cutting Width 126" (3.20m)

~ ~ Selection 1 ~ Choose a Basic Unit, Drive Package ~ ~

| | | Retail Price | Contract Price |
|----------|---|--------------|----------------|
| C187-100 | FX1200C, Basic Unit <i>c/w replaceable side bands & hydraulic phasing system</i> | 22,925.00 | 15,589.00 |
| S000-085 | Safety Light Kit (Required) <u>DRIVE PACKAGE</u> (choose one) | 673.00 | 457.64 |
| C307-700 | CW Rotation on Center, 540 RPM | 5,415.00 | 3,682.20 |
| C307-710 | CW Rotation on Center, 1000 RPM | 5,415.00 | 3,682.20 |

~ ~ Selection 2 ~ Choose a Hitch Option ~ ~

| | | | |
|----------|--|----------|----------|
| C185-180 | Trailing Hitch, CV Style Choose a CV Shaft: | 997.00 | 677.96 |
| a) | 340-870WG CV Shaft, 540 RPM | 1,880.00 | 1,278.40 |
| b) | 340-648WG CV Shaft, 1000 RPM | 1,557.00 | 1,058.76 |
| C185-196 | Equal Angle Hitch Kit w/ 540 RPM Shaft | 3,180.00 | 2,162.40 |

~ ~ Selection 3 ~ Choose a Clevis ~ ~

| | | | |
|------------|------------------------------------|--------|--------|
| C000-506WG | Open Clevis (Minimum Requirements) | 475.00 | 323.00 |
| C000-500WG | Precision hitch | 860.00 | 584.80 |
| C000-513WG | Solid Tongue | 558.00 | 379.44 |
| C000-510WG | Pro Level Hitch | 776.00 | 527.68 |

~ ~ Selection 4 ~ Choose One Center Axle Mount Style ~ ~

| | | | |
|----------|--|----------|----------|
| C185-820 | Walking (<i>Axles Included</i>) | 2,971.00 | 2,020.28 |
| C185-830 | Non Walking (<i>2 Tire Kit, Axles Included</i>) | 1,059.00 | 720.12 |
| C185-825 | Non Walking (<i>4 Tire Kit, Axles Included</i>) | 1,649.00 | 1,121.32 |
| C186-880 | Wheel Mounts For Large Tires (<i>Includes hubs/spindles & Tires</i>) | 4,150.00 | 2,822.00 |

If choosing the C186-880, you MUST choose the C185-840 wing axle mount & one tire

* Above prices subject to a 4% steel tariff surcharge

MASTER PRICE SHEET



Schulte Industries Ltd.

100 John Schulte Dr., Englefeld, SK. Canada, S0K 1N0
 Tel: 306-287-3715 Fax: 306-287-3355 Toll Free: 1-800-404-6044
 Web: www.Schulte.ca



Sourcewell - Road Right Of Way Maintenance Equipment

MACHINE PRICES AND SPECIFICATIONS

FX-1200C Rotary Cutter (DOT Configuration Options)

~ ~ Selection 5 ~ Choose a Wing Axle Mount Style ~ ~

| | | | |
|----------|---|----------|--------|
| C185-835 | Walking Axle (Axle Included) | 1,402.00 | 953.36 |
| C185-840 | Non Walking (1 Tire Kit, Axle Included) | 524.00 | 356.32 |
| C185-845 | Non Walking (2 Tire Kit, Axles Included) | 730.00 | 496.40 |

~ ~ Selection 6 ~ Choose a Safety Guard ~ ~

| | | | |
|----------|----------------------------------|----------|--------|
| C190-520 | Chain Guards Single Front & Rear | 907.00 | 616.76 |
| C190-500 | Chain Guards Double Front & Rear | 1,156.00 | 786.08 |

~ ~ Selection 7 ~ Choose The Pan Kit ~ ~

| | | | |
|----------|--------------------|----------|----------|
| C317-450 | Pan Kit (required) | 1,476.00 | 1,003.68 |
|----------|--------------------|----------|----------|

~ ~ Selection 8 ~ Choose a Blade Configuration ~ ~

| | | | |
|----------|---------------------------|--------|--------|
| C317-451 | Updraft Blades, CW Center | 436.00 | 296.48 |
|----------|---------------------------|--------|--------|

~ ~ Selection 9 ~ Choose a Tire Option ~ ~

Please state the quantity of tires that you would like to order as the numbers listed below are single tires and not tire kits.

| | | Retail Price/Tire | Contract Price/Tire |
|------------|---|-------------------|---------------------|
| 210-003WG | Solid Laminated Tires, 6 x 9 x 20 | 316.00 | 214.88 |
| 210-175WG | Tire Assy, Forklift, 6.5 x 10 - 12 ply on 2 pce 5 bolt rim | 445.00 | 302.60 |
| 210-175FWG | Foam Filled Forklift Tire 6.5 x 10 - 12 ply on 2 pce 5 bolt rim | 776.00 | 527.68 |
| 210-540WG | Tire 24x8-14 20 Ply Rated Severe Duty | 519.00 | 352.92 |
| 210-540FWG | Tire 24x8-14 20 Ply Rated Severe Duty Foam Filled | 825.00 | 561.00 |
| 210-192WG | Solid Laminated Tire, 6 x 9 x 26 | 509.00 | 346.12 |

~ ~ Selection 10 ~ Choose a Destination Code ~ ~

| | | | |
|---------|---------------------------------------|-------|-------|
| C195-NA | North American & Australian Decal Kit | 57.00 | 38.76 |
|---------|---------------------------------------|-------|-------|

* Above prices subject to a 4% steel tariff surcharge

MASTER PRICE SHEET



Schulte Industries Ltd.

100 John Schulte Dr., Englefeld, SK. Canada, S0K 1N0

Tel: 306-287-3715 Fax: 306-287-3355 Toll Free: 1-800-404-6044

Web: www.Schulte.ca



Sourcewell - Road Right Of Way Maintenance Equipment

MACHINE PRICES AND SPECIFICATIONS

FX-1200C Rotary Cutter (DOT Configuration Options)

~ ~ Selection 11 ~ Choose a Extra Options ~ ~

| | | | |
|----------|--|-----------------|---------------|
| C185-304 | Strut Mount for Flex Arm,(Factory Installed) | 876.00 | 595.68 |
| C185-305 | Strut Mount for Flex Arm, (parts only) | 368.00 | 250.24 |
| C185-325 | Tension Link Leveling Rod , Factory Installed | 310.00 | 210.80 |
| C185-330 | Tension Link Leveling Rod , Weld on Parts only | 388.00 | 263.84 |
| C000-620 | Toolbox Mount & Toolbox | 1,285.00 | 873.80 |
| | Assembly Charge | Net | 300.00 |



*** Above prices subject to a 4% steel tariff surcharge**

MASTER PRICE SHEET



Schulte Industries Ltd.

100 John Schulte Dr., Englefeld, SK. Canada, S0K 1N0
 Tel: 306-287-3715 Fax: 306-287-3355 Toll Free: 1-800-404-6044
 Web: www.Schulte.ca



Sourcewell - Road Right Of Way Maintenance Equipment

MACHINE PRICES AND SPECIFICATIONS

GX-150 Rotary Cutter

CUTTER FEATURES

- 540/1000 RPM Drive
- 80 Degree CV Drive
- High inertia blade carrier
- Height Control Cylinder & Hoses
- Replaceable Skid Shoes
- Wing Lift Cylinders & Hoses
- 10 ga Single Domed Deck cap.)
- S000-010 Safety Chain (1/4" gr.70 - 10000lbs
- Deck Protection Rings
- Operator's and Parts Manual Holder
- Over Center Folding Wings
- Cutting Width 180" (4.57m)

~~ Selection 1 ~ Choose a Basic Unit, Drive Package ~~

| | | Retail Price | Contract Price |
|-------------------------|---|--------------|----------------|
| C170-100 | GX-150 Base Unit | 20,189.00 | 13,728.52 |
| S000-085 | Safety Light Kit (Required) | 673.00 | 457.64 |
| Choose a Drive Package: | | | |
| a) | C170-705 Drive Package, CW Center, 540 RPM | 5,545.00 | 3,770.60 |
| b) | C170-715 Drive Package, CW Center, 1000 RPM | 5,545.00 | 3,770.60 |

~~ Selection 2 ~ Choose a Hitch Option ~~

| | | | |
|--------------------|------------------------------|----------|--------|
| C185-180 | Trailing Hitch, CV Style | 997.00 | 677.96 |
| Choose a CV Shaft: | | | |
| a) | 340-834WG CV Shaft, 540 RPM | 1,315.00 | 894.20 |
| b) | 340-676WG CV Shaft, 1000 RPM | 1,115.00 | 758.20 |

~~ Selection 3 ~ Choose a Clevis ~~

| | | | |
|------------|----------------------------|--------|--------|
| C000-510WG | Pro Level Hitch (Required) | 776.00 | 527.68 |
|------------|----------------------------|--------|--------|

~~ Selection 4 ~ Choose a Safety Guard ~~

| | | | |
|----------|------------------------------------|----------|----------|
| C180-520 | Chain Guards Single Front and Rear | 1,318.00 | 896.24 |
| C180-500 | Chain Guards Double Front and Rear | 1,671.00 | 1,136.28 |

~~ Selection 5 ~ Choose a Pan Kit ~~

| | | | |
|----------|--------------------|----------|----------|
| C170-450 | Pan Kit (required) | 1,945.00 | 1,322.60 |
|----------|--------------------|----------|----------|

* Above prices subject to a 4% steel tariff surcharge

MASTER PRICE SHEET



Schulte Industries Ltd.

100 John Schulte Dr., Englefeld, SK. Canada, S0K 1N0
 Tel: 306-287-3715 Fax: 306-287-3355 Toll Free: 1-800-404-6044
 Web: www.Schulte.ca



Sourcewell - Road Right Of Way Maintenance Equipment

MACHINE PRICES AND SPECIFICATIONS

GX-150 Rotary Cutter

~ ~ Selection 6 ~ Choose a Blade Configuration ~ ~

| | | | |
|----------|--|--------|--------|
| C316-451 | CW Schulte Super Suction Updraft 4" Blades | 657.00 | 446.76 |
|----------|--|--------|--------|

~ ~ Selection 7 ~ Choose an Axle Kit ~ ~

| | | | |
|----------|----------------------|----------|----------|
| C180-484 | Axle Kit for 4 Tires | 869.00 | 590.92 |
| C180-486 | Axle Kit for 6 Tires | 1,388.00 | 943.84 |
| C180-488 | Axle Kit for 8 Tires | 1,977.00 | 1,344.36 |

~ ~ Selection 8 ~ Choose a Tire Option ~ ~

Please state the quantity of tires that you would like to order as the number listed below is single tires and not tire kits.

| | | | |
|-----------|--|--------|--------|
| 210-175WG | Forklift Tire 6.5 x 10, 12 ply rated on 2 pce 5 bolt rim | 445.00 | 302.60 |
| 210-192WG | Solid Laminated Tire, 6 x 9 x 26 | 509.00 | 346.12 |
| 210-003WG | Solid Laminated Tires, 6 x 9 x 20 | 316.00 | 214.88 |

~ ~ Selection 9 ~ Choose a Destination Code ~ ~

| | | | |
|---------|---------------------------------------|-------|-------|
| C170-NA | North American & Australian Decal Kit | 61.00 | 41.48 |
|---------|---------------------------------------|-------|-------|

~ ~ Selection 10 ~ Choose Extra Options ~ ~

| | | | |
|----------|---|----------|--------|
| C185-325 | Tension Link Leveling Rod , Factory Installed | 310.00 | 210.80 |
| C000-620 | Toolbox Mount & Toolbox | 1,285.00 | 873.80 |

| | | |
|------------------------------|-----|--------|
| Assembly Charge on Pan Units | Net | 300.00 |
|------------------------------|-----|--------|

PREDELIVERY SERVICE IS REQUIRED BY DEALER OR END USER



* Above prices subject to a 4% steel tariff surcharge

MASTER PRICE SHEET



Schulte Industries Ltd.

100 John Schulte Dr., Englefeld, SK. Canada, S0K 1N0
 Tel: 306-287-3715 Fax: 306-287-3355 Toll Free: 1-800-404-6044
 Web: www.Schulte.ca



Sourcewell - Road Right Of Way Maintenance Equipment

MACHINE PRICES AND SPECIFICATIONS

GX-130 Rotary Cutter

CUTTER FEATURES

- 540 RPM Drive
- High inertia blade carrier
- Replaceable Skid Shoes
- 10 ga Single Domed Deck cap.)
- Deck Protection Rings
- Over Center Folding Wings
- 80 Degree CV Drive
- Height Control Cylinder & Hoses
- Wing Lift Cylinders & Hoses
- S000-010 Safety Chain (1/4" gr.70 - 10000lbs)
- Operator's and Parts Manual Holder
- Cutting Width 13 ft (3.96m)

~ ~ Selection 1 ~ Choose a Basic Unit, Drive Package ~ ~

| | | Retail Price | Contract Price |
|-------------------------|---|--------------|----------------|
| C130-100 | GX-130 Base Unit (Required) | 19,304.00 | 13,126.72 |
| S000-085 | Safety Light Kit (Required) | 673.00 | 457.64 |
| Choose a Drive Package: | | | |
| a) | C130-705 Drive Package, CW Center, 540 RPM (Required) | 4,275.00 | 2,907.00 |

~ ~ Selection 2 ~ Choose a Hitch Option & Power Shaft ~ ~

| | | | |
|--------------------|--|----------|--------|
| C185-180 | Trailing Hitch, CV Style (Required) | 997.00 | 677.96 |
| Choose a CV Shaft: | | | |
| a) | 340-834WG CV Shaft, 540 RPM (Required) | 1,315.00 | 894.20 |

~ ~ Selection 3 ~ Choose a Clevis ~ ~

| | | | |
|------------|-----------------|--------|--------|
| C000-510WG | Pro Level Hitch | 776.00 | 527.68 |
| C000-513WG | Solid tongue | 558.00 | 379.44 |

~ ~ Selection 4 ~ Choose a Safety Guard ~ ~

| | | | |
|----------|------------------------------------|----------|--------|
| C130-520 | Chain Guards Single Front and Rear | 1,167.00 | 793.56 |
| C130-500 | Chain Guards Double Front and Rear | 1,355.00 | 921.40 |

~ ~ Selection 5 ~ Choose a Pan Kit ~ ~

| | | | |
|----------|-------------------------|----------|----------|
| C130-450 | Flat Pan Kit (Required) | 1,539.00 | 1,046.52 |
|----------|-------------------------|----------|----------|

* Above prices subject to a 4% steel tariff surcharge

MASTER PRICE SHEET



Schulte Industries Ltd.

100 John Schulte Dr., Englefeld, SK. Canada, S0K 1N0
 Tel: 306-287-3715 Fax: 306-287-3355 Toll Free: 1-800-404-6044
 Web: www.Schulte.ca



Sourcewell - Road Right Of Way Maintenance Equipment

MACHINE PRICES AND SPECIFICATIONS

GX-130 Rotary Cutter

~ ~ Selection 6 ~ Choose a Blade Configuration ~ ~

| | | | |
|----------|---|--------|--------|
| C130-451 | CW Schulte Super Suction Updraft 4" Blades (Required) | 689.00 | 468.52 |
|----------|---|--------|--------|

~ ~ Selection 7 ~ Choose an Axle Kit ~ ~

| | | | |
|----------|---|----------|--------|
| C180-484 | Axle Kit for 4 Tires (Two tires on center, one tire on each wing) | 869.00 | 590.92 |
| C180-486 | Axle Kit for 6 Tires (Duals on center, one tire on each wing) | 1,388.00 | 943.84 |

~ ~ Selection 8 ~ Choose a Tire Option ~ ~

Please state the quantity of tires that you would like to order as the number listed below is single tires and not tire kits.

| | | | |
|-----------|--|--------|--------|
| 210-175WG | Forklift Tire 6.5 x 10, 12 ply rated on 2 pce 5 bolt rim | 445.00 | 302.60 |
| 210-003WG | Solid Laminated Tires, 6 x 9 x 20 | 316.00 | 214.88 |

~ ~ Selection 9 ~ Choose a Destination Code ~ ~

| | | | |
|---------|--|-------|-------|
| C130-NA | North American & Australian Decal Kit (Required For North America) | 61.00 | 41.48 |
|---------|--|-------|-------|

~ ~ Selection 10 ~ Choose Extra Options ~ ~

| | | | |
|----------|---|------------|--------|
| C130-250 | Wheel Covers <i>(For use in orchards to prevent the tires from grabbing fruit)</i> | 480.00 | 326.40 |
| | Assembly Charge on Pan Units | Net 300.00 | |

PREDELIVERY SERVICE IS REQUIRED BY DEALER OR END USER

IMPORTANT:

- 1) Safety Chain Kit must be used at all times when moving equipment on any type of road.
- 2) OSHA, ASAE, SAE, and ANSI standards REQUIRE the use of Chain Guards, Deflectors, or Solid Skirts/Bands at all times. Schulte recommends mower be equipped with deflectors or double chain guards for all mowing purposes. Single chain guards may be used for agricultural purposes only and are specifically not recommended for highway, right-of-way, parks or greenbelt mowing. Before ordering a mower, read the Thrown Object Shield Message in the Rotary Cutter Spec section in sales price book.



* Above prices subject to a 4% steel tariff surcharge

MASTER PRICE SHEET



Schulte Industries Ltd.

100 John Schulte Dr., Englefeld, SK. Canada, S0K 1N0

Tel: 306-287-3715 Fax: 306-287-3355 Toll Free: 1-800-404-6044

Web: www.Schulte.ca



Sourcewell - Road Right Of Way Maintenance Equipment

MACHINE PRICES AND SPECIFICATIONS

FLX-1510 Flex Arm

FLEX ARM FEATURES

- New heavy duty 11l x 15, 2 ply tires, load cap. Of 4000 lbs
- Cut directly in-line with the tractor or at any offset distance upto 122"
- 6000 lb capacity, 6 bolt hubs
- Spring steel bushings, induction harden pins at major pivot points
- Minimum of 3 hydraulic circuits required to operate with 15' or 10' mower
- Heavy duty 3-1/2 x 36 welded hydraulic cylinder
- Opt. 6 port selector valve kit for independent wing action or limited tractor hydraulic outlets
- Continuous power rating 200hp @ 1000rpm
- Bolt in replacement axles
- Safety light kit
- Operator's manual in holder

~ ~ Selection 1 ~ Choose a Basic Unit ~ ~

| | | Retail Price | Contract Price |
|----|----------------------------------|--------------|----------------|
| 1) | A105-000 FLX 1510 Flexarm | 36,705.00 | 24,959.40 |

~ ~ Selection 2 ~ Choose a Flex Arm Strut ~ ~

| | | | |
|----|---|--------|--------|
| 1) | A105-127WG Strut for attaching a XH1000/XH1500 | 344.00 | 233.92 |
| 2) | A105-227WG Strut for attaching a FX1200/FX1800 | 344.00 | 233.92 |

~ ~ Selection 3 ~ Choose Tires ~ ~

| | | | |
|----|---|----------|----------|
| 1) | 210-514WG Tire, 12 x 16.5 Skid Steer Tire | 1,240.00 | 843.20 |
| 2) | 210-330WG Tire, 33 x 12, Non-Directional 231 Boss Solid No Puncture Tire | 2,100.00 | 1,428.00 |

~ ~ Selection 4 ~ Extra Options ~ ~

| | | | |
|----|---|----------|---|
| 1) | A105-350 Six Port Selector Valve Kit for Independent Wing <i>Must pick if the tractor has only 3 valve banks, and the Flex Arm is being hooked to a 15' cutter</i> | 1,853.00 | 1,260.04 |
| 2) | A105-360 Hose kit for independent wing lift- Tractors with 4 valve banks <i>Must pick if the tractor has 4 valve banks, and the Flex Arm is being hooked to a 15' cutter</i> | 326.00 | 221.68 |
| 3) | C306-835 Independent Double Acting Cylinder Kit <i>XH1500 S4 Only - Hose kit for XH1500 to make independent wing lift, only order if the mower does not have it and the customer wants to have down pressure on the wings</i> | | * To order this kit, please contact the Schulte Parts Department |
| 4) | C307-835 Independent Double Acting Cylinder Kit <i>XH1000 S4 Only - Hose kit for XH1000 to make independent wing lift, only order if the mower does not have it and the customer wants to have down pressure on the wing</i> | | * To order this kit, please contact the Schulte Parts Department |
| 5) | C000-300WG Precision Hitch <i>Precision hitch only, customer will receive precision hitch as well as the adjustable clevis (Standard)</i> | 631.00 | 429.08 |

Assembly

Net

300.00

IMPORTANT: OSHA, ASAE, SAE, and ANSI standards REQUIRE the use of Chain Guards, Deflectors, or Solid Skirts/Bands at all times. Schulte recommends mower be equipped with deflectors or double chain guards for all mowing purposes. Single chain guards may be used for agricultural purposes only and are specifically not recommended for highway, right-of-way, parks or greenbelt mowing. Before ordering a mower, read the Thrown ObjectShield Information Message in the Rotary Cutter Spec Section in the sales price book.



*** Above prices subject to a 4% steel tariff surcharge**

MASTER PRICE SHEET



Schulte Industries Ltd.

100 John Schulte Dr., Englefeld, SK. Canada, S0K 1N0

Tel: 306-287-3715 Fax: 306-287-3355 Toll Free: 1-800-404-6044

Web: www.Schulte.ca



Sourcewell - Road Right Of Way Maintenance Equipment

MACHINE PRICES AND SPECIFICATIONS

FX-209 Rotary Cutter

CUTTER FEATURES - ALL HITCH TYPES

- Push or pull capability
- 9ft / 3m overall width
- Cutting Height: 2" - 13" (5.1 cm - 33 cm)
- Cutting Width: 109.25" (2.78 m)
- Cutting Capacity: 3" (7.6 cm)
- Minimum Tractor HP 50 HP (37.3 kW)
- Cat. II & III 3 Point / Semi Mount Swing (13" left or right swing), Trailing Pull
- Gearbox Rating 210 hp
- Two rotor base unit common to all configuration
- Pans with Schulte Super Suction Blades
- Double Chain Front & Rear
- 7 Ga Deck
- 540 and 1000 RPM drive options

~ ~ Selection 1 ~ Choose a FX-209 Base Unit ~ ~

| | | Retail Price | Contract Price |
|----------|------------------|--------------|----------------|
| C209-100 | FX-209 Base Unit | 12,113.00 | 8,236.84 |

~ ~ Selection 2 ~ Choose a FX-209 Non Trailing Configuration

| | | | |
|----------|--|----------|----------|
| | Choose One Mount | | |
| C209-300 | 3PT Mount Option | 2,889.00 | 1,964.52 |
| | Choose One Drive Package | | |
| C209-710 | 540 RPM Drive Package <i>NON-TRAILING</i> or | 2,125.00 | 1,445.00 |
| C209-715 | 1000 RPM Drive Package <i>NON-TRAILING</i> | 2,125.00 | 1,445.00 |
| | Choose One Wheel Assembly | | |
| C209-400 | FX-209 Wheel Assembly Non-Trailing Standard or | 2,550.00 | 1,734.00 |
| C209-450 | FX-209 Wheel Assembly Non-Trailing Hydraulic | 3,679.00 | 2,501.72 |

~ ~ Selection 3 ~ Choose a FX-209 Trailing Hitch

| | | | |
|------------|---|----------|----------|
| C209-340 | FX-209 Trailing Hitch | 5,438.00 | 3,697.84 |
| CS01-106WG | Open Clevis (<i>Minimum Requirement</i>) or | 225.00 | 153.00 |
| C000-360WG | Adjustable Clevis or | 342.00 | 232.56 |
| C000-300WG | Precision Hitch or | 631.00 | 429.08 |
| C502-113WG | Solid Tongue | 279.00 | 189.72 |
| | Choose One Drive Package | | |
| C209-700 | 540 RPM Drive Package Trailing or | 3,820.00 | 2,597.60 |
| C209-705 | 1000 RPM Drive Package Trailing | 3,960.00 | 2,692.80 |

* Above prices subject to a 4% steel tariff surcharge

MASTER PRICE SHEET



Schulte Industries Ltd.

100 John Schulte Dr., Englefeld, SK. Canada, S0K 1N0

Tel: 306-287-3715 Fax: 306-287-3355 Toll Free: 1-800-404-6044

Web: www.Schulte.ca



Sourcewell - Road Right Of Way Maintenance Equipment

MACHINE PRICES AND SPECIFICATIONS

FX-209 Rotary Cutter

~ ~ Selection 4 ~ Choose Options ~ ~

| | | | |
|-----------------|---|-----------------|-----------------|
| C209-250 | Blade Pan Option (Must Pick) | 1,949.00 | 1,325.32 |
| C209-520 | Half Length Belting Option (Front and Back) | 293.00 | 199.24 |

~ ~ Selection 5 ~ Choose Tire Options ~ ~

(CHOOSE 2 TIRES PER UNIT)

| | | Retail Price/Tire | Contract Price/Tire |
|-------------------|---|-------------------|---------------------|
| 210-003WG | Solid Laminated Tires, 6 x 9 x 20 | 316.00 | 214.88 |
| 210-540WG | Tire 24x8-14 20 Ply Rated Severe Duty | 519.00 | 352.92 |
| 210-540FWG | Tire 24x8-14 20 Ply Rated Severe Duty Foam Filled | 825.00 | 561.00 |
| 210-175WG | Forklift New, 6.5 x 10 - 12 ply rated on 2 pcs 5 bolt rin | 445.00 | 302.60 |
| 210-175FWG | Foam Filled Forklift Tire 6.5 x 10 - 12 ply on 2 pce 5 bolt rim | 776.00 | 527.68 |

| | | | |
|-----------------|------------|--|---------------|
| Assembly | Net | | 300.00 |
|-----------------|------------|--|---------------|



*** Above prices subject to a 4% steel tariff surcharge**

MASTER PRICE SHEET



Schulte Industries Ltd.

100 John Schulte Dr., Englefeld, SK. Canada, S0K 1N0
 Tel: 306-287-3715 Fax: 306-287-3355 Toll Free: 1-800-404-6044
 Web: www.Schulte.ca



Sourcewell - Road Right Of Way Maintenance Equipment

MACHINE PRICES AND SPECIFICATIONS

FX-107 Rotary Cutter

CUTTER FEATURES - ALL HITCH TYPES

- Rigid single domed 7 gauge deck construction
- Overall width: 95.5" (2.43 m)
- Cutting Height: 3" - 12 7/8" (7.6 cm - 33 cm)
- Cutting Width: 84" (2.13 m)
- Cutting Capacity: 3" (7.6 cm)
- Minimum Tractor HP 50 HP (37.3 kW)
- Cat. II & III 3 Point / Trailing Pull
- Pull type and 3 point hitch options
- Base unit common to all configurations
- 540 RPM drive
- Double Chain Front & Rear
- 7 Ga Deck
- Pull type unit has the ability to accept open clevis, solid tongue & adjustable clevis

~ ~ Selection 1 ~ Choose a Base Unit ~ ~

| | | Retail Price | Contract Price |
|----------|------------------|--------------|----------------|
| C107-100 | FX-107 Base Unit | 8,244.00 | 5,605.92 |

~ ~ Selection 2 ~ Choose a 3 Point Option Configuration ~ ~

| | | | |
|----------|---|----------|----------|
| C107-300 | 3PT Mount Option <i>(if this chosen skip Trailing Hitch Option)</i> | 4,986.00 | 3,390.48 |
|----------|---|----------|----------|

~ ~ Selection 3 ~ Choose a Trailing Hitch Configuration ~ ~

| | | | |
|------------|---|----------|----------|
| C107-195 | Trailing Hitch | 6,995.00 | 4,756.60 |
| CS01-106WG | Open Clevis <i>(Minimum Requirement) or</i> | 225.00 | 153.00 |
| C000-360WG | Adjustable Clevis <i>or</i> | 342.00 | 232.56 |
| C000-300WG | Precision Hitch <i>or</i> | 631.00 | 429.08 |
| C502-113WG | Solid Tongue | 279.00 | 189.72 |

~ ~ Selection 4 ~ Blade Pan Option ~ ~

| | | | |
|----------|------------------------------|----------|--------|
| C107-250 | Blade Pan Option (Must Pick) | 1,225.00 | 833.00 |
|----------|------------------------------|----------|--------|

~ ~ Selection 5 ~ Choose Tire Options ~ ~

| | | Retail Price/Tire | Contract Price/Tire |
|----------------------------------|---|-------------------|---------------------|
| (CHOOSE 2 TIRES PER UNIT) | | | |
| 210-003WG | Solid Laminated Tires, 6 x 9 x 20 | 316.00 | 214.88 |
| 210-540WG | Tire 24x8-14 20 Ply Rated Severe Duty | 519.00 | 352.92 |
| 210-540FWG | Tire 24x8-14 20 Ply Rated Severe Duty Foam Filled | 825.00 | 561.00 |
| 210-175WG | Forklift New, 6.5 x 10 - 12 ply rated on 2 pcs 5 bolt rim | 445.00 | 302.60 |
| 210-175FWG | Foam Filled Forklift Tire 6.5 x 10 - 12 ply on 2 pce 5 bolt rim | 776.00 | 527.68 |
| | Assembly | Net | 250.00 |



* Above prices subject to a 4% steel tariff surcharge

MASTER PRICE SHEET



Schulte Industries Ltd.

100 John Schulte Dr., Englefeld, SK. Canada, S0K 1N0

Tel: 306-287-3715 Fax: 306-287-3355 Toll Free: 1-800-404-6044

Web: www.Schulte.ca

Sourcewell - Road Right Of Way Maintenance Equipment

MACHINE PRICES AND SPECIFICATIONS



Eliminator

ELIMINATOR FEATURES

- Chemical application spray kit for XH1500
- Adjustable Flow rate (can be matched to the product you are using)
- Monitor for speed, pressure and application rates
- 50 US Gallon (189 Litres) Capacity Tank
- Great for brush and weed control
- Reduce drift while mowing-
Spraying is done unnder the deck

~ ~ Selection 1 ~ Choose a Basic Unit ~ ~

| | Retail Price | Contract Price |
|----------------------------------|---------------------|-----------------------|
| 1) C350-675 Eliminator Spray Kit | 12,705.00 | 8,639.40 |
| Factory Installation on XH1500 | Net | 675.00 |
| Crated For Shipping | Net | 200.00 |



* Above prices subject to a 4% steel tariff surcharge